

## SaniForce® 2150, 3000, 4000, Electric-Operated Diaphragm Pump

3A5133M<sub>EN</sub>

2-Inch, 3-Inch, and 4-Inch pumps with electric drive for fluid transfer applications.  
Not approved for use in explosive atmospheres or hazardous (classified) locations unless otherwise stated. See Approvals page for more information. For professional use only.



### Important Safety Instructions

Read all warnings and instructions in this manual and in your Operation manual before using the equipment. **Save these instructions.**

*For maximum working pressure, see Technical Specification sheets.*

*See page 10 for approvals.*

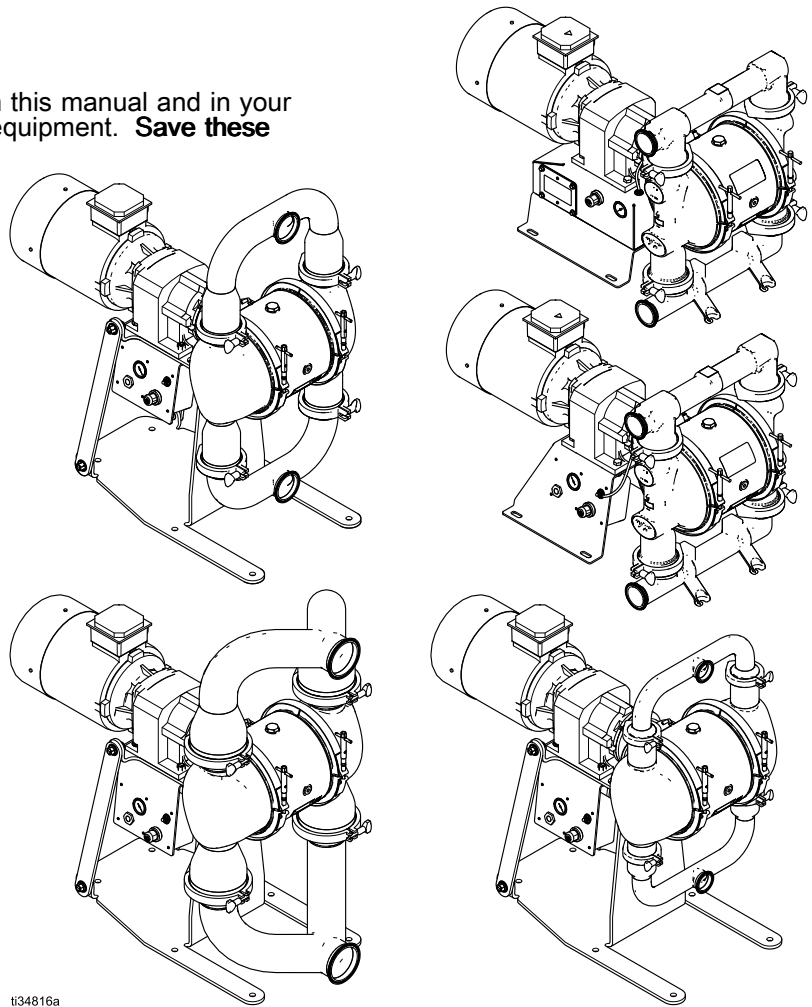

t134816a

# Contents



Related Manuals .....	2	Repair.....	14
Warnings .....	3	Pressure Relief Procedure.....	14
Configuration Number Matrix for 2150 FG Pumps.....	6	Check Valve Repair .....	14
Configuration Number Matrix for 2150, 3000, and 4000 HS Pumps .....	8	Standard Diaphragm Repair .....	17
Approvals.....	10	Overmolded Diaphragm Repair.....	19
Ordering Information.....	11	Center Section Repair .....	21
Troubleshooting.....	12	Install Compressor Kits.....	26
		Replace the Compressor .....	27
		Parts.....	28
		Kits and Accessories.....	38
		Technical Specifications.....	39







## Related Manuals







Manual Number	Title
3A5132	SaniForce™ 2150, 3000, 4000, Electric-Operated Diaphragm Pump, Operation







# Warnings

The following warnings are for the setup, use, grounding, maintenance, and repair of this equipment. The exclamation point symbol alerts you to a general warning and the hazard symbols refer to procedure-specific risks. When these symbols appear in the body of this manual or on warning labels, refer back to these Warnings. Product-specific hazard symbols and warnings not covered in this section may appear throughout the body of this manual where applicable.

 <span style="font-size: 2em; font-weight: bold; color: white;">DANGER</span>	
 	<p><b>SEVERE ELECTRIC SHOCK HAZARD</b></p> <p>This equipment can be powered by more than 240 V. Contact with this voltage will cause death or serious injury.</p> <ul style="list-style-type: none"> <li>Turn off and disconnect power at main switch before disconnecting any cables and before servicing equipment.</li> <li>This equipment must be grounded. Connect only to grounded power source.</li> <li>All electrical wiring must be done by a qualified electrician and comply with all local codes and regulations.</li> </ul>

 <span style="font-size: 2em; font-weight: bold; color: black;">WARNING</span>	
    	<p><b>FIRE AND EXPLOSION HAZARD</b></p> <p>Flammable fumes, such as solvent, in <b>work area</b> can ignite or explode. Solvent flowing through the equipment can cause static sparking. To help prevent fire and explosion:</p> <ul style="list-style-type: none"> <li>Use equipment only in well ventilated area.</li> <li>Eliminate all ignition sources; such as pilot lights, cigarettes, portable electric lamps, and plastic drop cloths (potential static sparking).</li> <li>Ground all equipment in the work area. See <b>Grounding</b> instructions.</li> <li>Keep work area free of debris, including solvent, rags and gasoline.</li> <li>Do not plug or unplug power cords, or turn power or light switches on or off when flammable fumes are present.</li> <li>Use only grounded lines.</li> <li><b>Stop operation immediately</b> if static sparking occurs or you feel a shock. Do not use equipment until you identify and correct the problem.</li> <li>Keep a working fire extinguisher in the work area.</li> </ul> <p>Static charge may build up on plastic parts during cleaning and could discharge and ignite flammable vapors. To help prevent fire and explosion:</p> <ul style="list-style-type: none"> <li>Clean plastic parts only in well ventilated area.</li> <li>Do not clean with a dry cloth.</li> </ul>

 <h1 style="margin: 0;">WARNING</h1>	
  	<p><b>PRESSURIZED EQUIPMENT HAZARD</b></p> <p>Fluid from the equipment, leaks, or ruptured components can splash in the eyes or on skin and cause serious injury.</p> <ul style="list-style-type: none"> <li>• Follow the <b>Pressure Relief Procedure</b> when you stop spraying/dispensing and before cleaning, checking, or servicing equipment.</li> <li>• Tighten all fluid connections before operating the equipment.</li> <li>• Check fluid lines, tubes, and couplings daily. Replace worn or damaged parts immediately.</li> </ul>
 	<p><b>EQUIPMENT MISUSE HAZARD</b></p> <p>Misuse can cause death or serious injury.</p> <ul style="list-style-type: none"> <li>• Do not operate the unit when fatigued or under the influence of drugs or alcohol.</li> <li>• Do not exceed the maximum working pressure or temperature rating of the lowest rated system component. See <b>Technical Specifications</b> in all equipment manuals.</li> <li>• Use fluids and solvents that are compatible with equipment wetted parts. See <b>Technical Specifications</b> in all equipment manuals. Read fluid and solvent manufacturer's warnings. For complete information about your material, request Safety Data Sheet (SDS) from distributor or retailer.</li> <li>• Turn off all equipment and follow the <b>Pressure Relief Procedure</b> when equipment is not in use.</li> <li>• Check equipment daily. Repair or replace worn or damaged parts immediately with genuine manufacturer's replacement parts only.</li> <li>• Do not alter or modify equipment. Alterations or modifications may void agency approvals and create safety hazards.</li> <li>• Make sure all equipment is rated and approved for the environment in which you are using it.</li> <li>• Use equipment only for its intended purpose. Call your distributor for information.</li> <li>• Route fluid lines and cables away from traffic areas, sharp edges, moving parts, and hot surfaces.</li> <li>• Do not kink or over bend fluid lines or use fluid lines to pull equipment.</li> <li>• Keep children and animals away from work area.</li> <li>• Comply with all applicable safety regulations.</li> </ul>
	<p><b>PRESSURIZED ALUMINUM PARTS HAZARD</b></p> <p>Use of fluids that are incompatible with aluminum in pressurized equipment can cause serious chemical reaction and equipment rupture. Failure to follow this warning can result in death, serious injury, or property damage.</p> <ul style="list-style-type: none"> <li>• Do not use 1,1,1-trichloroethane, methylene chloride, other halogenated hydrocarbon solvents or fluids containing such solvents.</li> <li>• Do not use chlorine bleach.</li> <li>• Many other fluids may contain chemicals that can react with aluminum. Contact your material supplier for compatibility.</li> </ul>

 <h1 style="margin: 0;">WARNING</h1>	
	<p><b>THERMAL EXPANSION HAZARD</b></p> <p>Fluids subjected to heat in confined spaces, including lines, can create a rapid rise in pressure due to the thermal expansion. Over-pressurization can result in equipment rupture and serious injury.</p> <ul style="list-style-type: none"> <li>• Open a valve to relieve the fluid expansion during heating.</li> <li>• Replace lines proactively at regular intervals based on your operating conditions.</li> </ul>
	<p><b>PLASTIC PARTS CLEANING SOLVENT HAZARD</b></p> <p>Many solvents can degrade plastic parts and cause them to fail, which could cause serious injury or property damage.</p> <ul style="list-style-type: none"> <li>• Use only compatible solvents to clean plastic structural or pressure-containing parts.</li> <li>• See <b>Technical Specifications</b> in all equipment manuals for materials of construction. Consult the solvent manufacturer for information and recommendations about compatibility.</li> <li>• See <b>Technical Specifications</b> in this and all other equipment instruction manuals. Read fluid and solvent manufacturer's Safety Data Sheet (SDS) and recommendations.</li> </ul>
	<p><b>TOXIC FLUID OR FUMES HAZARD</b></p> <p>Toxic fluids or fumes can cause serious injury or death if splashed in the eyes or on skin, inhaled, or swallowed.</p> <ul style="list-style-type: none"> <li>• Read Safety Data Sheet (SDS) to know the specific hazards of the fluids you are using.</li> <li>• Store hazardous fluid in approved containers, and dispose of it according to applicable guidelines.</li> </ul>
	<p><b>BURN HAZARD</b></p> <p>Equipment surfaces and fluid that's heated can become very hot during operation. To avoid severe burns:</p> <ul style="list-style-type: none"> <li>• Do not touch hot fluid or equipment.</li> </ul>
	<p><b>PERSONAL PROTECTIVE EQUIPMENT</b></p> <p>Wear appropriate protective equipment when in the work area to help prevent serious injury, including eye injury, hearing loss, inhalation of toxic fumes, and burns. This protective equipment includes but is not limited to:</p> <ul style="list-style-type: none"> <li>• Protective eyewear, and hearing protection.</li> <li>• Respirators, protective clothing, and gloves as recommended by the fluid and solvent manufacturer.</li> </ul>

# Configuration Number Matrix for 2150 FG Pumps

Check the identification plate (ID) for the Configuration Number of your pump. Use the following matrix to define the components of your pump.

When you receive your pump, record the 9 character part number found on the shipping box (e.g., SP1B.0014):

\_\_\_\_\_

Also record the configuration number on the pump ID plate to assist you when ordering replacement parts:

\_\_\_\_\_

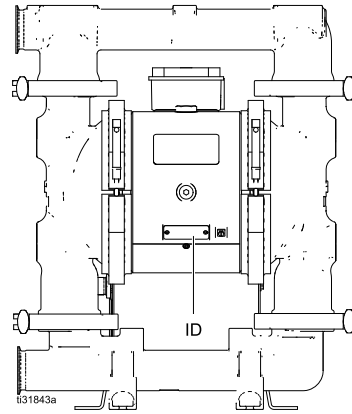

**Sample Configuration Number: 2150FG-EA04AS13SSPTPTPT21**

<b>2150</b>	<b>FG</b>	<b>E</b>	<b>A</b>	<b>04</b>	<b>A</b>	<b>S13</b>	<b>SS</b>	<b>PT</b>	<b>PT</b>	<b>PT</b>	<b>21</b>
Pump Model	Wetted Section	Drive	Center Section	Gear Box and Compressor	Motor	Fluid Covers and Manifolds	Seats	Balls or Checks	Diaphragms	Manifold Seals	Certification

Pump	Wetted Section		Drive Type		Center Section Material		Gearbox and Compressor		Motor	
	<b>2150</b>	<b>FG</b>	Food Grade	<b>E</b>	Electric	<b>A</b>	Aluminum	<b>94</b>	No Gearbox or Compressor	<b>A</b>
					<b>S</b>	Stainless Steel	<b>04</b>	High Speed Gear Ratio	<b>C</b>	ATEX Induction Motor
							<b>05</b>	High Speed Gear Ratio/120V Compressor	<b>D</b>	Flameproof Induction Motor
							<b>06</b>	High Speed Gear Ratio/240V Compressor	<b>G</b>	No Motor
							<b>14</b>	Mid Speed Gear Ratio		
							<b>15</b>	Mid Speed Gear Ratio/120V Compressor		
							<b>16</b>	Mid Speed Gear Ratio/240V Compressor		
							<b>24</b>	Low Speed Gear Ratio		
							<b>25</b>	Low Speed Gear Ratio/120V Compressor		
							<b>26</b>	Low Speed Gear Ratio/240V Compressor		

Configuration Number Matrix for 2150 FG Pumps

Fluid Covers and Manifolds		Seat Material		Ball or Check Material		Diaphragm Material		Manifold Seals		Certification	
<b>S13</b>	Stainless steel, TriClamp	<b>SS</b>	316 Stainless Steel	<b>CW</b>	Polychloroprene Weighted	<b>PT</b>	PTFE/EPDM 2-Piece	<b>EP</b>	EPDM	blank	no certification
<b>S14</b>	Stainless steel, DIN			<b>PT</b>	PTFE	<b>SP</b>	Santoprene/EPDM 2-Piece	<b>PT</b>	PTFE	<b>21</b>	EN 10204 type 2.1
				<b>SP</b>	Santoprene					<b>31</b>	EN 10204 type 3.1

# Configuration Number Matrix for 2150, 3000, and 4000 HS Pumps

Check the identification plate (ID) for the Configuration Number of your pump. Use the following matrix to define the components of your pump.

When you receive your pump, record the 9 character part number found on the shipping box (e.g., SP1B.0014):

Also record the configuration number on the pump ID plate to assist you when ordering replacement parts:

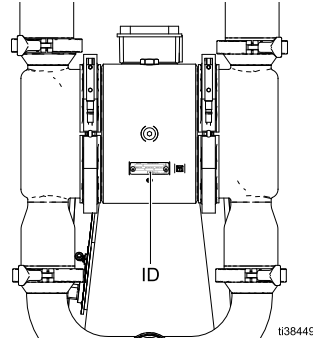

Sample Configuration Number: **2150HS-ES04ASSASSPTPSEP21**

<b>2150</b>	<b>HS</b>	<b>E</b>	<b>S</b>	<b>04</b>	<b>A</b>	<b>SSA</b>	<b>SS</b>	<b>PT</b>	<b>PS</b>	<b>EP</b>	<b>21</b>
Pump Model	Wetted Section	Drive	Center Section	Gear Box and Compressor	Motor	Fluid Covers and Manifolds	Seats	Balls or Checks	Diaphragms	Manifold Seals	Certification







Pump	Wetted Section		Drive Type		Center Section Material		Gearbox and Compressor			Motor	
<b>2150</b>	<b>HS</b>	High Sanitation	<b>E</b>	Electric	<b>S</b>	Stainless Steel	<b>94</b>	No Gearbox or Compressor	<b>A</b>	Standard Induction Motor	
<b>3000</b>	<b>3A</b>	3A Certified					<b>04</b>	High Speed Gear Ratio	<b>C</b>	ATEX Induction Motor	
<b>4000</b>	<b>PH</b>	Pharmaceutical					<b>05</b>	High Speed Gear Ratio/120V Compressor	<b>D</b>	Flameproof Induction Motor	
							<b>06</b>	High Speed Gear Ratio/240V Compressor	<b>G</b>	No Motor	
							<b>14</b>	Mid Speed Gear Ratio			
							<b>15</b>	Mid Speed Gear Ratio/120V Compressor			
							<b>16</b>	Mid Speed Gear Ratio/240V Compressor			
							<b>24</b>	Low Speed Gear Ratio			
							<b>25</b>	Low Speed Gear Ratio/120V Compressor			
			<b>26</b>	Low Speed Gear Ratio/240V Compressor							



Configuration Number Matrix for 2150, 3000, and 4000 HS Pumps

Fluid Covers and Manifolds		Seat Material		Ball or Check Material		Diaphragm Material		Manifold Seals		Certification	
<b>SSA</b>	Stainless Steel, Tri-Clamp (HS/ 3-A/ PH)	<b>FL</b>	316 Stainless Steel Flapper	—	Flapper, check, Stainless Steel	<b>BN</b>	Buna-N	<b>BN</b>	Buna-N	<b>21</b>	EN 10204 type 2.1
<b>SSB</b>	Stainless Steel, DIN (HS/3-A/PH)	<b>SS</b>	316 Stainless Steel	<b>BN</b>	Buna-N	<b>EO</b>	EPDM Overmolded	<b>EP</b>	EPDM	<b>31</b>	EN 10204 type 3.1
				<b>CW</b>	Polychloroprene Weighted	<b>FK</b>	FKM Fluoroelastomer	<b>FK</b>	FKM		
				<b>FK</b>	FKM Fluoroelastomer	<b>PS</b>	PTFE/Santoprene 2-Piece				
				<b>PT</b>	PTFE	<b>SP</b>	Santoprene/EPDM 2Piece				
				<b>SP</b>	Santoprene						

# Approvals

Approvals		
◆ Pumps with motor code <b>C</b> are approved to:		II 2 G Ex h d IIB T3 Gb
✚ Pumps with motor code <b>G</b> are approved to:		II 2 G Ex h IIB T3 Gb
★ Motors coded <b>D</b> are approved to:	 	Class I, Div 1, Group D, T3B Class II, Div 1, Group F & G, T3B
Diaphragm materials coded <b>EO</b> , <b>PT</b> , or <b>PS</b> combined with check materials coded <b>FL</b> or <b>PT</b> comply with:		EC 1935/2004
All Models (except gearbox and compressor codes 05, 15, and 25, or motor code <b>D</b> ) are approved to:		
Diaphragm materials coded <b>EO</b> , <b>PT</b> or <b>PS</b> combined with check materials coded <b>FL</b> or <b>PT</b> comply with:		Class VI
All fluid contact materials are FDA-compliant and meet the United States Code of Federal Regulations (CFR).		

# Ordering Information

## To Find Your Nearest Distributor

Visit [www.graco.com](http://www.graco.com)

## To Specify the Configuration of a New Pump

Please call your distributor.

OR

Use the Online Diaphragm Pump Selector Tool at [www.graco.com](http://www.graco.com). Search for **Selector**.

## To Order Replacement Parts

Please call your distributor.

# Troubleshooting



- Follow the [Pressure Relief Procedure, page 14](#), before checking or servicing the equipment.
- Check all possible problems and causes before disassembly.

Problem	Cause	Solution
Pump cycles but will not prime and/or pump.	Pump is running too fast, causing cavitation before prime.	Slow down the controller (VFD)
	Center section has no air pressure, or air pressure is too low.	Apply air pressure to center section per your application requirements.
	Check valve ball is severely worn or wedged in seat or manifold.	Replace the ball and seat.
	The pump has insufficient suction pressure.	Increase the suction pressure. See the Operation manual.
	Seat is severely worn.	Replace the ball and seat.
	Outlet or inlet is restricted.	Remove the restriction.
	Inlet fittings or manifolds are loose.	Tighten.
	Manifold o-rings are damaged.	Replace o-rings.
The center section is excessively hot.	The drive shaft is broken.	Replace.
Pump fails to hold fluid pressure at stall. <b>NOTE:</b> Flapper checks are not 100% fluid tight.	Check valve balls, seats, or o-rings are worn.	Replace.
	Manifold screws or fluid cover screws are loose.	Tighten.
	Diaphragm shaft bolt is loose.	Tighten.
	Flap valves installed upside-down.	Install the flapper valve with the text side facing the seat.
Pump will not cycle.	Motor or controller is wired improperly.	Wire per manual.
	The leak detector (if installed) has tripped.	Check diaphragm for rupture or incorrect installation. Repair or replace.
The motor is operating, but the pump will not cycle.	The jaw coupling between the motor and gearbox is not connected properly.	Check the connection.
Pump flow rate is erratic.	Suction line is clogged.	Inspect; clear.
	Checks are sticky or leaking.	Clean or replace.
	Diaphragm (or backup) ruptured.	Replace.
Pump makes unusual noises.	Pump is operating near or at stall pressure.	Adjust air pressure or slow the pump speed.

Problem	Cause	Solution
Air consumption is higher than expected.	A fitting is loose.	Tighten. Inspect thread sealant.
	Loose or damaged o-rings or shaft seal.	Replace.
	Diaphragm (or backup) ruptured.	Replace.
Air bubbles in fluid.	Suction line is loose.	Tighten.
	Diaphragm (or backup) ruptured.	Replace.
	Loose manifolds, damaged seats or o-rings.	Tighten manifold bolts or replace seats or o-rings.
	Loose diaphragm shaft bolt.	Tighten.
Pump leaks fluid externally from joints.	Loose manifold screws or fluid cover screws.	Tighten.
	Manifold o-rings worn out.	Replace o-rings.
The controller faults or shuts down.	A GFCI has tripped.	Remove the controller from the GFCI circuit.
	Supply power is poor.	Determine and fix the source of the power problem.
	Operational parameters are exceeded.	See performance chart; ensure pump is operating within the continuous duty range.
Excessive motor regeneration fault from VFD	Inlet check clogged/improperly installed	Remove debris/install properly
	Broken diaphragm bolt	Replace bolt

**NOTE:** For problems with a Variable Frequency Device (VFD), see your VFD manual.

# Repair

**NOTE:** When reassembling fluid section components, loosely assemble initially to ensure acceptable alignment. Once all components are in place, tighten all clamps.

## Pressure Relief Procedure



Follow the Pressure Relief Procedure whenever you see this symbol.



This equipment stays pressurized until pressure is manually relieved. To help prevent serious injury from pressurized fluid, such as splashing fluid, follow the Pressure Relief Procedure when you stop dispensing and before cleaning, checking, or servicing the equipment.

1. Turn off the pump and disconnect power to the system.
2. Close the master air valve (J) to shut off the air to the pump.
3. Open the fluid drain valve (L) to relieve fluid pressure. Have a container ready to catch the drainage.
4. Close the pump air inlet port (E) on the pneumatic enclosure.

## Check Valve Repair

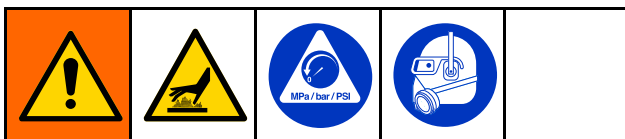

### Tools Required

- O-ring pick

**NOTE:** Kits are available for new check valve balls and seats in a range of materials. O-ring kits also are available.

**NOTE:** To ensure proper seating of the check balls, always replace the seats when replacing the balls. Also, replace the o-rings every time the manifold is removed.

## Disassemble the Ball Check Valve

1. Follow the [Pressure Relief Procedure, page 14](#). Disconnect power from the motor. Disconnect all fluid and air lines.
2. Remove the clamps (31) holding the outlet manifold (3) to the fluid covers (2), then remove the outlet manifold.
3. Remove the ball check valve assemblies:
  - a. On the 2150FG, remove the seats (6), balls (7), and o-rings (8).
  - b. On the 2150HS, remove the ball stops (28), balls (7), and gaskets (8a).
4. Repeat for the inlet manifold.
5. To continue with diaphragm disassembly, see [Disassemble the Standard Diaphragms, page 17](#).

## Reassemble the Ball Check Valve

1. Clean all parts and inspect for wear or damage. Replace parts as needed.
2. Reassemble in the reverse order, following all notes in the illustration. Put the inlet manifold on first. Be sure the ball checks and manifolds are assembled **exactly** as shown. If present on the fluid covers (2), the arrows (A) **must** point toward the outlet manifold (3). For fluid covers without arrows, the tallest opening in the fluid cover **must** be attached to the outlet manifold.

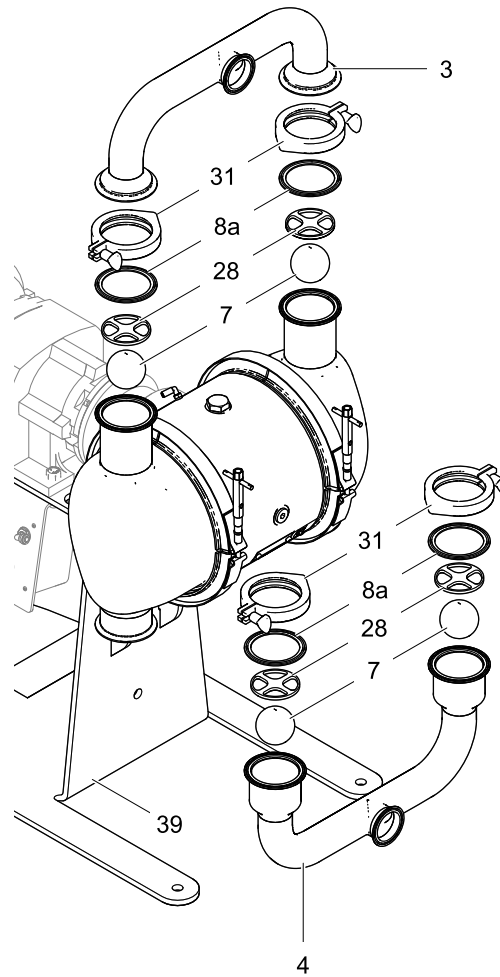
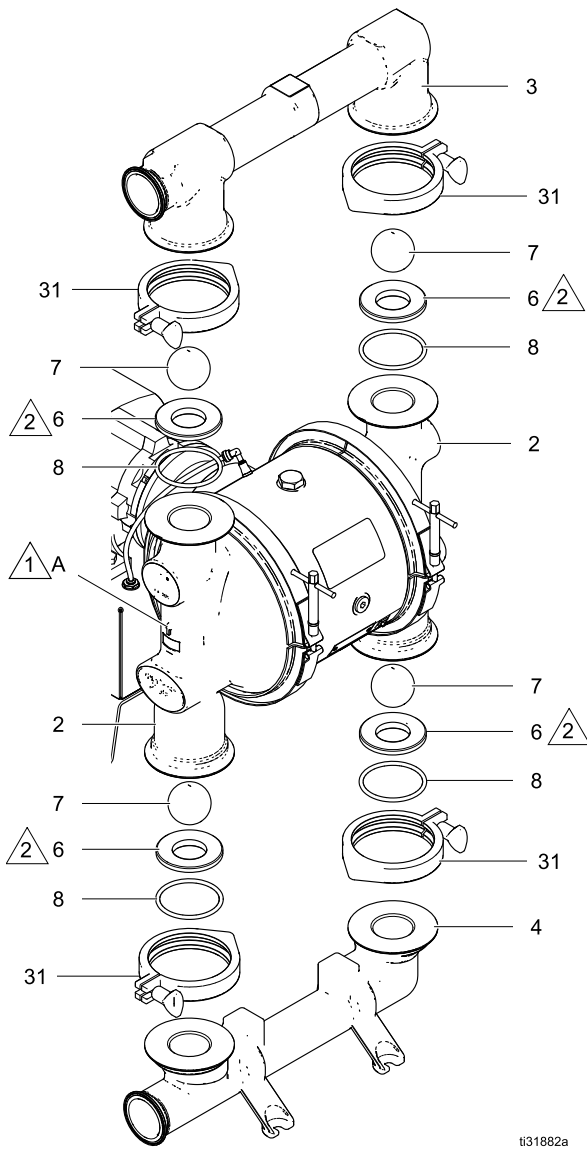

Arrow (A) must point toward outlet manifold.



Radiused seating surface must face the ball (7). Large chamfer on O.D. must face o-ring.

## Disassemble the Flapper Check Valve

1. Follow the [Pressure Relief Procedure, page 14](#). Disconnect power from the motor. Disconnect all fluid and air lines.
2. Remove the clamps (31) holding the outlet manifold (3) to the fluid covers, then remove the outlet manifold.
3. Remove the flappers (7a), and gaskets (8a).
4. Repeat steps to remove the inlet manifold (4). Remove the flappers (7a), and gaskets (8a).
5. To continue with diaphragm disassembly, see [Disassemble the Standard Diaphragms, page 17](#).

## Reassemble the Flapper Check Valve

1. Clean all parts and inspect for wear or damage. Replace parts as needed.
2. Reassemble in the reverse disassembly order. Put the inlet manifold on first. Be sure the flapper checks and manifolds are assembled **exactly** as shown.

**NOTE:** Install the flapper valves (7a) with the text side facing the seat.

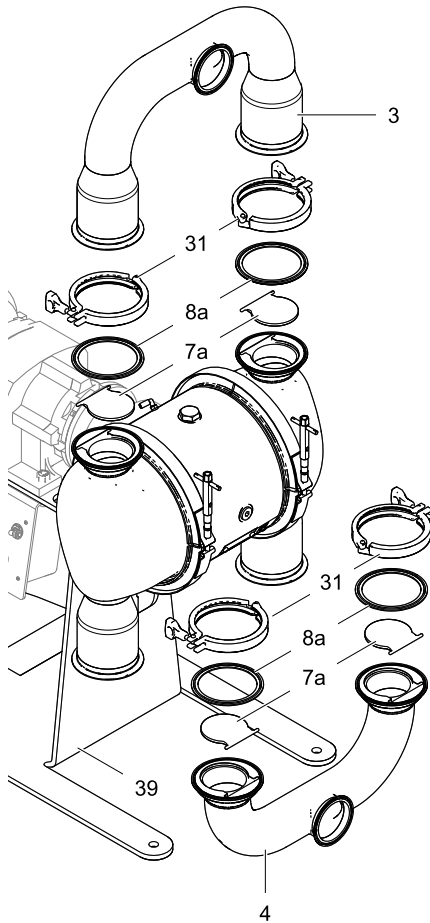

ti34853a



## Standard Diaphragm Repair

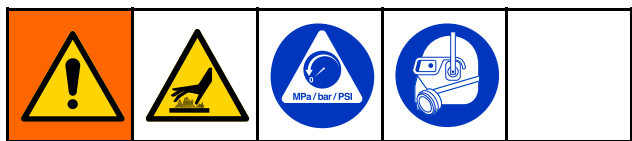

### Tools Required

- Torque wrench
- 10 mm hex key wrench
- 28 mm open end wrench
- O-ring pick

### Disassemble the Standard Diaphragms

**NOTE:** Diaphragm kits are available in a range of materials and styles. See Parts section.

1. Follow the [Pressure Relief Procedure, page 14](#). Disconnect power from the motor. Disconnect all fluid and air lines.
2. Remove the manifolds and disassemble the ball check valves as explained in [Check Valve Repair, page 14](#).
3. Remove the clamps (30) from the fluid covers, then pull the fluid covers off of the pump.
4. To remove the diaphragms, the piston must be moved fully to one side. If the pump is not attached to the gearbox, turn the shaft by hand to move the piston. If the pump is still attached to the gearbox, loosen the screws and remove the fan cover. Turn the fan by hand to rotate the shaft to shift the piston to one side.

**TIP:** The air cover has 2 holes (H), one at the 9 o'clock position and another at the 3 o'clock position. Use pin (131), placed in either hole (H) as a brace for the wrench while removing or installing diaphragm bolts.

- a. Hold a 28 mm wrench on the wrench flats of the exposed piston shaft. Use another wrench (10 mm hex key) on the shaft bolt (13) to remove it. Then remove all parts of the diaphragm assembly.

- b. Rotate the drive shaft to move the piston fully to the other side. Repeat step 4a.
5. To continue with center section disassembly, see [Disassemble the Center Section, page 21](#).

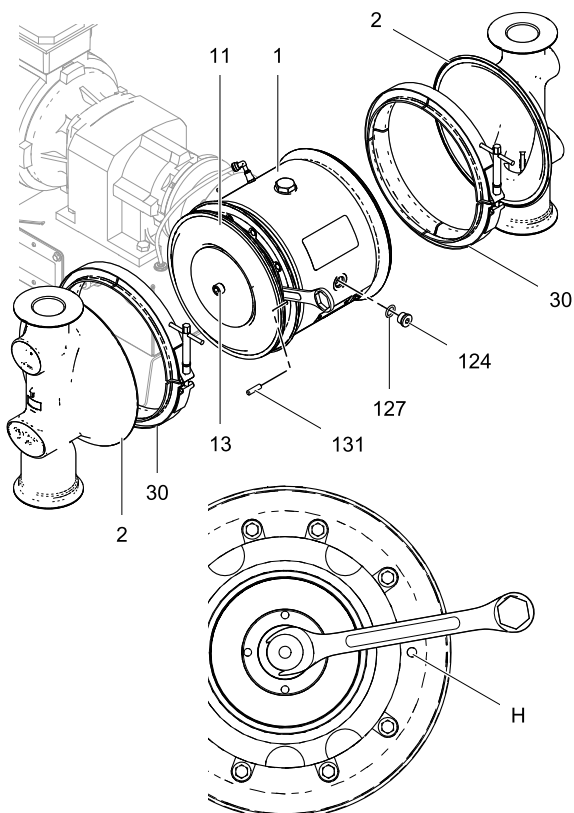

ti31883a

## Reassemble the Standard Diaphragms

### NOTICE

After reassembly, allow the thread locker to cure for 12 hours, or per manufacturer's instructions, prior to operating the pump. Damage to the pump will occur if the diaphragm shaft bolt loosens.

**TIP:** If you are also repairing or servicing the center section (drive shaft, piston, etc.), follow [Center Section Repair, page 21](#), before replacing diaphragms.

1. Clean all parts and inspect for wear or damage. Replace parts as needed. Be sure the center section is clean and dry.
2. Thoroughly clean or replace the diaphragm bolt (13). Install the o-ring (34).
3. Assemble the fluid side plate (9), the diaphragm (11), the backup diaphragm (12, if present), and the air side diaphragm plate (10) on the bolt exactly as shown.
4. Clean the female threads of the piston shaft with a wire brush dipped in solvent to remove any residual thread locker. Apply thread-locking primer and allow it to dry.
5. Apply medium-strength (blue) thread locker to the threads of the bolt.
6. Hold a 28 mm wrench on the wrench flats of the piston shaft. Screw the bolt onto the shaft and torque to 100 ft-lb (135 N•m).
7. Rotate the drive shaft to move the piston fully to one side. See instructions in step 4 of [Disassemble the Standard Diaphragms, page 17](#).
8. Repeat to install the other diaphragm assembly.
9. Attach the fluid covers. The arrow on each fluid cover must point toward the outlet manifold.
10. Reassemble the check valves and manifolds. See [Reassemble the Ball Check Valve, page 14](#).
11. Restore motor cooling fan cover and pin (131) to their original locations.

- 1 Rounded side faces diaphragm.
- 2 Apply medium-strength (blue) thread locker to the threads.
- 3 AIR SIDE markings on diaphragm must face the center housing.
- 4 If the screw comes loose or is replaced, apply permanent (red) thread locker to diaphragm side threads. Apply medium-strength (blue) thread locker to shaft side threads.
- 5 Torque to 100 ft-lb (135 N•m) at 100 rpm maximum.
- 6 Apply primer to the female threads. Allow to dry.

### 2-Piece (PS, PT, or SP) Models

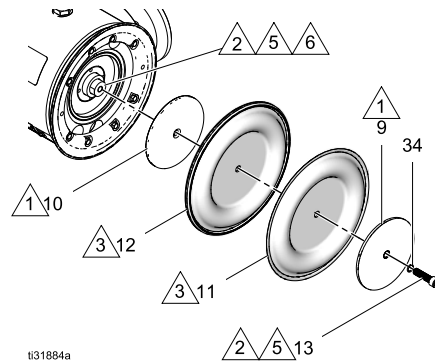

## Overmolded Diaphragm Repair

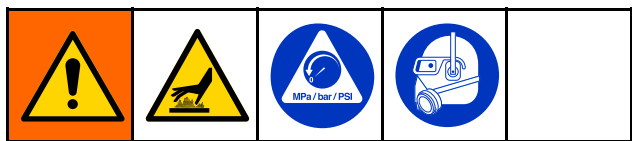

### Tools Required

- 28 mm open end wrench

### Disassemble the Overmolded Diaphragms

**NOTE:** Diaphragm kits are available in a range of materials and styles. See Parts section.

1. Follow the [Pressure Relief Procedure, page 14](#). Disconnect power from the motor. Disconnect all fluid and air lines.
2. Remove the manifolds and disassemble the ball check valves as explained in [Check Valve Repair, page 14](#).
3. Remove the clamps (30) from the fluid covers, then pull the fluid covers off of the pump.
4. To remove the diaphragms, the piston must be moved fully to one side. If the pump is not attached to the gearbox, turn the shaft by hand to move the piston. If the pump is still attached to the gearbox, loosen the screws and remove the fan cover. Turn the fan by hand to rotate the shaft to shift the piston to one side.

**TIP:** The air cover has 2 holes (H), one at the 9 o'clock position and another at the 3 o'clock position. Use pin (131), placed in either hole (H) as a brace for the wrench while removing or installing diaphragm bolts.

- a. Hold a 28 mm wrench on the wrench flats of the exposed piston shaft. Grip the diaphragm securely around the outer edge and rotate counterclockwise.

- b. Rotate the drive shaft to move the piston fully to the other side. Repeat step 4a.
5. To continue with center section disassembly, see [Disassemble the Center Section, page 21](#).

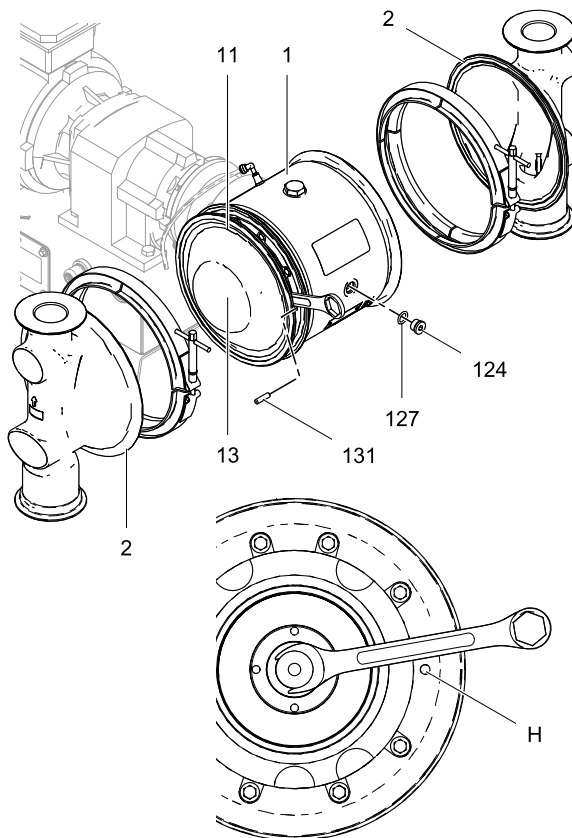

ti37206a

## Reassemble the Overmolded Diaphragms

### NOTICE

After reassembly, allow the thread locker to cure for 12 hours, or per manufacturer's instructions, prior to operating the pump. Damage to the pump will occur if the diaphragm shaft bolt loosens.

**TIP:** If you are also repairing or servicing the center section (drive shaft, piston, etc.), follow [Center Section Repair, page 21](#), before replacing diaphragms.

1. Clean all parts and inspect for wear or damage. Replace parts as needed. Be sure the center section is clean and dry.
2. Thoroughly clean or replace the diaphragm bolt (13). Install the o-ring (34).
3. Assemble the fluid side plate (9), the diaphragm (11), the backup diaphragm (12, if present), and the air side diaphragm plate (10) on the bolt exactly as shown.
4. Clean the female threads of the piston shaft with a wire brush dipped in solvent to remove any residual thread locker. Apply thread-locking primer and allow it to dry.
5. Apply medium-strength (blue) thread locker to the threads of the bolt.
6. Hold a 28 mm wrench on the wrench flats of the piston shaft. Screw the bolt onto the shaft and torque to 100 ft-lb (135 N•m).
7. Rotate the drive shaft to move the piston fully to one side. See instructions in step 4 of [Disassemble the Overmolded Diaphragms, page 19](#).
8. Repeat to install the other diaphragm assembly.
9. Attach the fluid covers.
10. Reassemble the check valves and manifolds. See [Reassemble the Ball Check Valve, page 14](#).
11. Restore motor cooling fan cover and pin (131) to their original locations.

- 1 Rounded side faces diaphragm.
- 2 Apply medium-strength (blue) thread locker to the threads.
- 3 Apply primer to the female threads. Allow to dry.

### 1-Piece (EO) Model

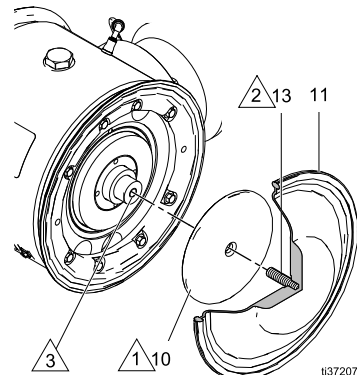

## Center Section Repair

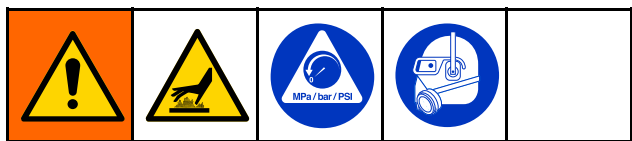

### Disassemble the Center Section

See the illustrations on page 18.

1. Follow the [Pressure Relief Procedure, page 14](#). Disconnect all fluid and air lines.
2. Remove the manifolds and check valve parts as directed in [Disassemble the Ball Check Valve, page 14](#).
3. Remove the fluid covers and diaphragms as directed in [Disassemble the Standard Diaphragms, page 17](#).  
**TIP:** Clamp the gear box bracket (15) to the bench. Leave the pump connected to the motor.
4. Use a 10 mm hex wrench to remove 4 bolts (117). Pull the pump off the alignment housing (116).  
**TIP:** It may be necessary to tap the pump with a rubber mallet to disengage the coupler.
5. Use a 5/16 hex wrench to remove the plug (124). Use a 30 mm socket wrench to remove the bearing bolt (106) and the o-ring (108) from the top.
6. Turn the drive shaft assembly (112) so the groove on the shaft is at the top, in line with the alignment markings.
7. Use a 3/4–16 bolt to push out the drive shaft assembly (112). You can also use the bearing bolt (106), but remove the bearing (107) first. Be sure that the groove on the drive shaft remains aligned with the markings in the center section.  
**NOTE:** Remove the bolt after the drive shaft is freed.

### NOTICE

Proper alignment is essential. Do not apply more than about 10 in-lb (1.1 N•m) of torque. Excessive torque could strip the housing thread. If you encounter resistance, check alignment or contact your distributor.

8. The shaft coupler (113) might come out with the drive shaft assembly. If not, remove from gearbox (118).
9. Remove the seal cartridge (110), the o-ring (109) and the radial seal (111) from the drive shaft assembly.
10. Slide the piston assembly (102) out of the center.
11. Only remove the alignment housing (116) if needed. Use a 10 mm hex wrench to remove 4 bolts (120). Pull the alignment housing off the gearbox (118).
12. Leave the gearbox coupler (114) attached to the gearbox shaft (118) unless it is damaged. If you need to remove it, a bearing puller must be used.

## Reassemble the Center Section

1. Clean and dry the center housing (101), the center of the piston (102) and the drive shaft (112).
2. Inspect the piston and center section bearings for excessive wear and replace if needed. Grease the piston as shown and install it in the center section with the slot on the top, in line with the alignment markings in the center section.
3. Install the o-ring (108) and apply medium-strength (blue) thread locker to the bearing bolt (106) and screw into the center section. Be sure that the bearing (107) is in the slot on the piston, as shown. Be sure that the piston moves freely. Torque the bolt to 15–25 ft-lb (20–34 N•m).

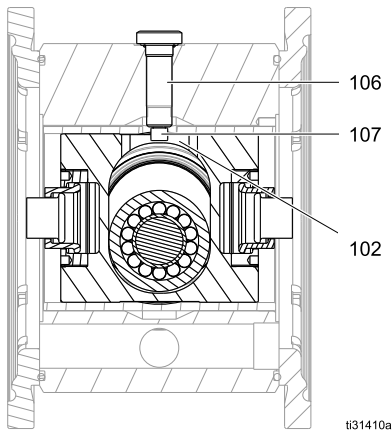

4. Be sure the sealing surface of the drive shaft (112) is clean. Install the seal cartridge (110) and the radial seal (111) on the drive shaft. The lips on the radial seal (111) must face **IN** toward the center. Inspect seal lip for damage. Replace if necessary.

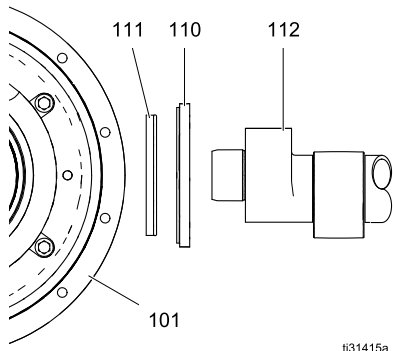

5. Install o-ring (109) to the center housing (101).
6. Apply anti-seize lubricant on the mating edges of the drive shaft, as shown in the illustration, page 18.
7. Center the piston in the housing and install the drive shaft assembly (112) into the center housing (101) with the groove facing up.
8. Inspect the shaft coupler (113) for wear and replace if needed. Install on the drive shaft.
9. If removed, install the alignment housing to the center section. Apply medium-strength (blue) thread locker and install the housing screws (117). Torque to 130–160 in-lb (15–18 N•m).
10. If removed, install the gearbox coupler (114) on the gearbox (118) shaft. Use an M12 x 30 bolt and a large washer inserted into the hole in the shaft to press the coupler into position. The coupler is in proper position when it is flush with the end of the shaft.
11. Be sure the gearbox coupler (114) is aligned properly. Turn by hand if needed. Connect the pump to the gearbox assembly, engaging the couplers.
12. Apply medium-strength (blue) thread locker and install the gearbox screws (120). Torque to 130–160 in-lb (15–18 N•m).
13. Be sure o-ring (127) is on the plug (124). Install the plug and torque to 15–25 ft-lb (20–34 N•m).
14. See [Reassemble the Standard Diaphragms, page 18](#), and [Reassemble the Ball Check Valve, page 14](#).

- 1 Apply medium-strength (blue) thread locker to threads.
- 2 Torque to 15–25 ft-lb (20–34 N•m).
- 3 Lips must face **IN** toward the center.
- 4 Apply anti-seize lubricant liberally on the radial surfaces of the drive shaft assembly.
- 5 Install the drive shaft assembly with the groove facing up.
- 6 Tighten screws in a crisscross pattern, 5 turns at a time, to engage the coupler evenly. Torque to 130–160 in-lb (15–18 N•m).
- 7 Apply lubricant to inner mating surface.

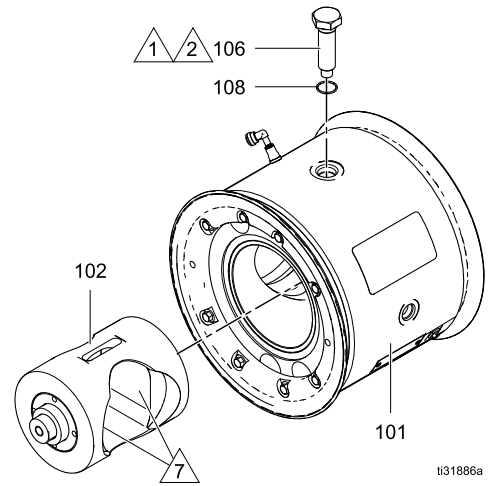

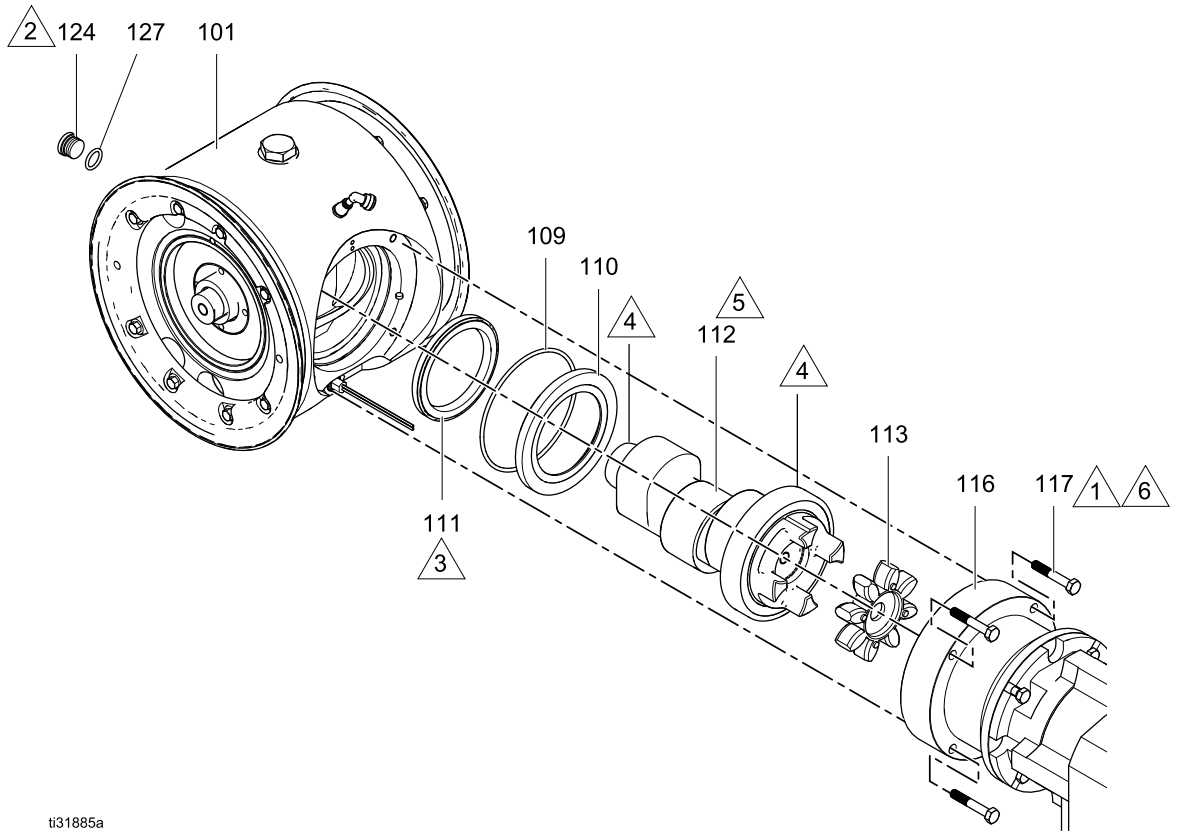

ti31886a



ti31885a

## Disconnect the Motor and Gearbox

				
<p>To avoid injury from fire, explosion, or electric shock, all electrical wiring must be done by a qualified electrician and comply with all local codes and regulations.</p>				

**NOTE:** Normally, the motor remains connected to the gearbox. Disconnect the motor only if you suspect that the motor or gearbox must be replaced.

**TIP:** Clamp the gearbox bracket (15) to the bench.

Start at step 1 for ATEX or Flameproof motors.  
Standard AC motors (04A, 05A, or 06A) are of one

piece with the gearbox, so begin with step 4.

**NOTE:** Use a hoist and sling to remove motor weight from the gearbox during removal.

1. Turn off the pump and disconnect power.
2. Use a 3/4 in. socket wrench to remove 4 screws (122).
3. Pull the motor (121) straight off of the gearbox (118).
4. Use a 3/4 in. socket wrench to remove 4 bolts (17) and nuts (18, if present). Lift the gear box off of the bracket.

**NOTE:** If you have an AC motor with gearbox, lift the whole unit off of the bracket.

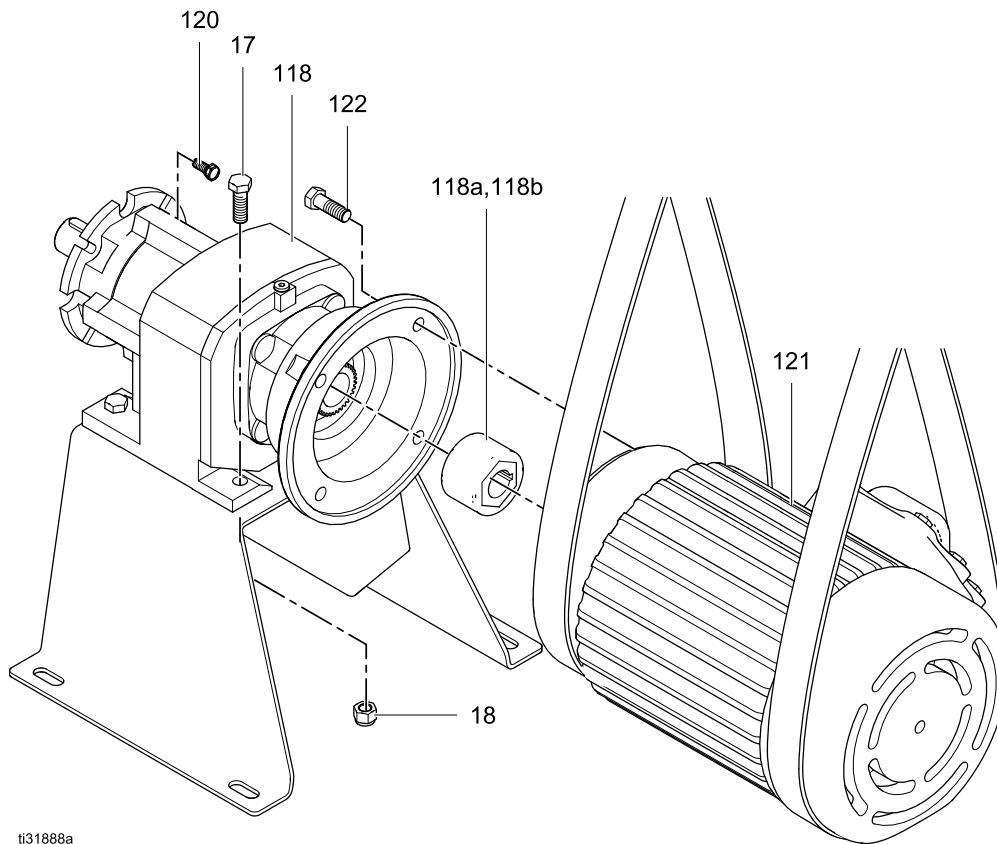

ti31888a



## Leak Sensor Repair

**NOTE:** A previous design of the leak sensor exists. If your leak sensor contains a jam nut, refer to manual 3A5133A for repair instructions.

The leak sensor can be replaced or re-positioned. When properly positioned, the two arrows imprinted on two of the flat surfaces of the leak sensor hex head are vertical and pointing down.

## Leak Sensor Testing

Testing the continuity of the leak sensor is possible to ensure proper operation. If continuity testing indicates that the leak sensor is not functional, a replacement kit, 25B435, can be ordered separately.

1. Follow the [Pressure Relief Procedure, page 14](#). Remove power from the motor.
2. To test the leak sensor without removing from the pump:
  - a. Note the connection locations of the leak sensor wires within the VFD or other monitoring device, then disconnect the leak sensor wires.
  - b. Use an ohmmeter attached to the leak sensor leads to test the conductivity of the leak sensor. Continuity is affirmed by a reading of 0-5 ohms.
  - c. Loosen the leak sensor bushing 1/2 turn (leak sensor arrows point up).
  - d. Use an ohmmeter attached to the leak sensor leads to test the conductivity of the leak sensor. An open circuit should be indicated.

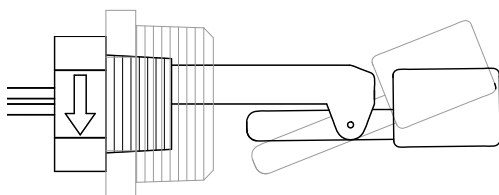



t133058a

Normal operation position shown by dark float. Lighter float line indicates the open circuit position.

- e. If the continuity tests result indicate that the leak sensor is not functioning properly, proceed to step 3. Otherwise, tighten the bushing to its original position so that the arrows on the leak sensor point down. Attach the removed leak sensor wires to the point where they were disconnected from the VFD or other monitoring device.
  - f. Apply air pressure to the pump and use a soapy solution around the bushing to ensure an air tight seal. If air bubbles appear, it will be necessary to return to the steps above for air pressure relief and removing the bushing from the pump. Apply new thread sealer on the bushing and install in the pump so that the leak sensor is properly positioned. Repeat this step to test for air leakage around the bushing.
3. Remove and replace the leak sensor at the pump:
    - a. Note the connection locations of the leak sensor wires within the VFD or other monitoring device, then disconnect the leak sensor wires.
    - b. Remove the leak sensor and bushing from the pump center section.
    - c. Apply thread tape or paste to the bushing threads and screw finger tight into the pump.
    - d. To ensure a watertight seal, apply Loctite® 425 Assure™ threadlocker supplied with the leak sensor kit to the leak sensor threads and screw the leak sensor into the bushing.
    - e. Verify that the leak sensor was properly oriented in the pump so that the arrows imprinted on the leak sensor hex head are vertical positioned with the arrows pointing down. It may be necessary to further tighten both the bushing and leak sensor to achieve proper positioning.
    - f. Use an ohmmeter attached to the leak sensor leads to test the conductivity of the leak sensor. Continuity is affirmed by a reading of 0-5 ohms. Attach the leak sensor wires to the VFD or other monitoring device.
    - g. Apply air pressure to the pump and use a soapy solution around the bushing to ensure an air tight seal. If air bubbles appear, it will be necessary to return to the steps above for air pressure relief and removing the bushing from the pump. Apply new thread sealer on the bushing and install in the pump so that the leak sensor is properly positioned. Repeat this step to test for air leakage around the bushing.

## Install Compressor Kits

				
<p>To avoid injury from fire, explosion, or electric shock, all electrical wiring must be done by a qualified electrician and comply with all local codes and regulations.</p>				

### Install Compressor Kits for FG Pumps

Follow this procedure to install your compressor kit for food grade pumps. See [Kits and Accessories, page 38](#) for compressor kit options.

1. Follow the [Pressure Relief Procedure, page 14](#).
2. Turn off the pump and Disconnect power to the unit.
3. Locate the illustration for your pump model under [Parts, page 28](#), for reference for installing your compressor kit.
4. Attach the riser bracket (35) to the compressor box (16) using bolts (35a).

**NOTE:** Be sure to align the slot from the riser bracket (35) with the compressor motor inside of the compressor box (16).

5. Attach the pump motor (121) to the compressor box (16) using bolts (17). Use medium-strength Loctite® to secure the bolts and torque to 27 N•m (20 ft-lb).
6. Refer to your pump Operation manual for wiring instructions.

### Install Compressor Kits for HS Pumps

Follow this procedure to install your compressor kit for high-sanitary pumps. See [Kits and Accessories, page 38](#) for compressor kit options.

1. Follow the [Pressure Relief Procedure, page 14](#).
2. Turn off the pump and Disconnect power to the unit.
3. Locate the illustration for your pump model under [Parts, page 28](#), for reference for installing your compressor kit.
4. Attach the cover (42) to the compressor (16) using bolts (43).



**NOTE:** Be sure to align the slot from the cover (42) with the compressor motor inside of the compressor (16).

5. Apply high-strength Loctite to the end of the screws (40), then fasten into the threaded nuts of the compressor (16) so that 4.13 cm (1.625 in.) of the screws show above the nut. Allow Loctite to cure according to manufacturer instructions.
6. Align the pump motor (121) on top of the mounting base (39).

**NOTE:** Use lifting straps to support the pump weight.

7. Position the compressor assembly (16) under the mounting base (39). Attach the compressor to the base using the screws (40) and nuts (18). Use medium-strength Loctite to secure the nuts and torque to 27 N•m (20 ft-lb).
8. Cover the exposed portion of the thread screws (40) with caps (41).
9. Refer to your pump Operation manual for wiring instructions.

## Replace the Compressor

				
<p>To avoid injury from fire, explosion, or electric shock, all electrical wiring must be done by a qualified electrician and comply with all local codes and regulations.</p>				

1. Follow the [Pressure Relief Procedure](#), page 14.
2. Remove electrical power from the pump.
3. Remove the 8 bolts holding the pump to the mounting surface.
4. Tip the pump on its side to provide access to the compressor box.
5. Remove riser bracket (35).
6. Remove the air line (A1) from the compressor. Disconnect the compressor wires at the terminal block (L1, L2, and ground). Remove the four bolts, and carefully pull the compressor out of the box.
7. Use the four bolts to install the new compressor. Connect the air line from A1 to A1, as shown.
8. Connect the wires from the new compressor to the terminal block, as shown.
9. Replace riser bracket.
10. Return the pump to its mounting location. Secure it with the 8 bolts.
11. Return power to the pump.

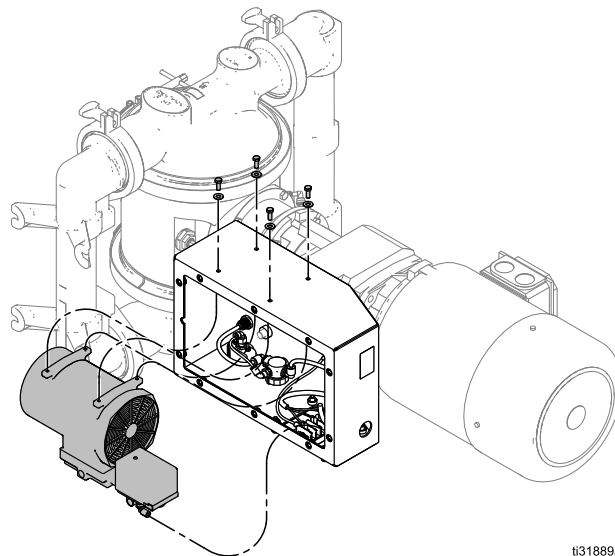

ti31889a

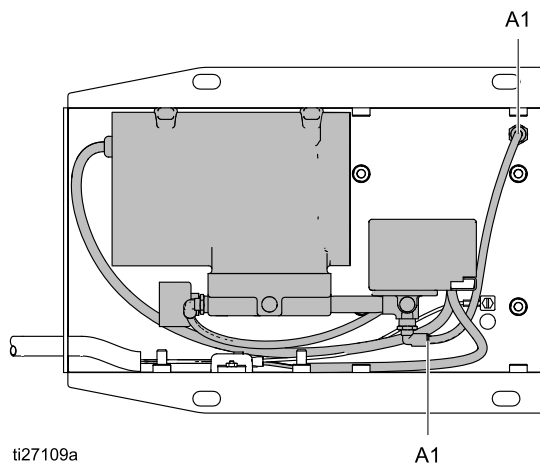

ti27109a

A1

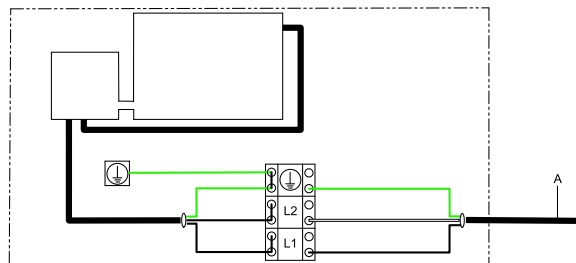

# Parts

## 2150FG Pump

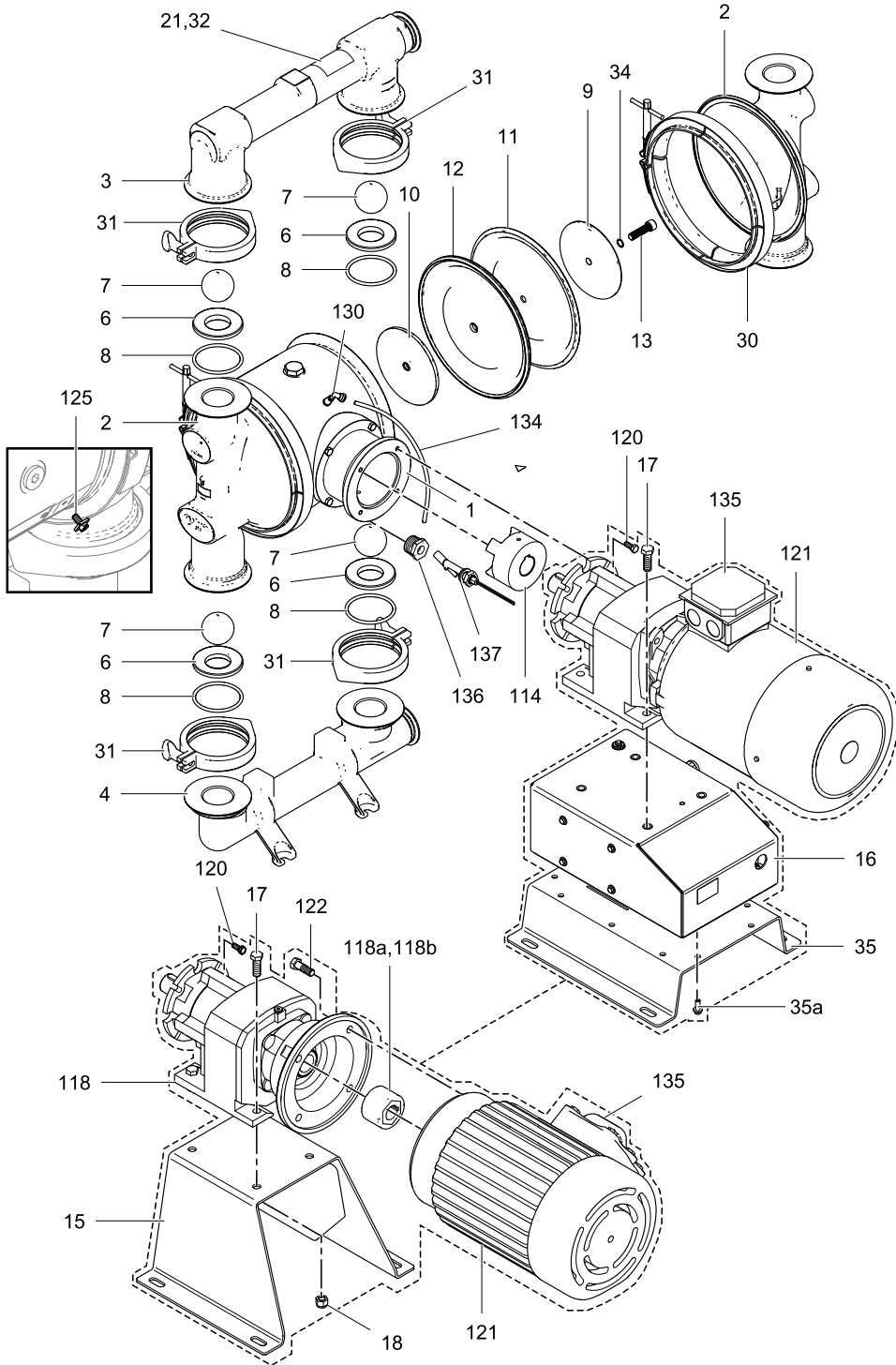

t31890a

# 2150HS Ball Check Pump

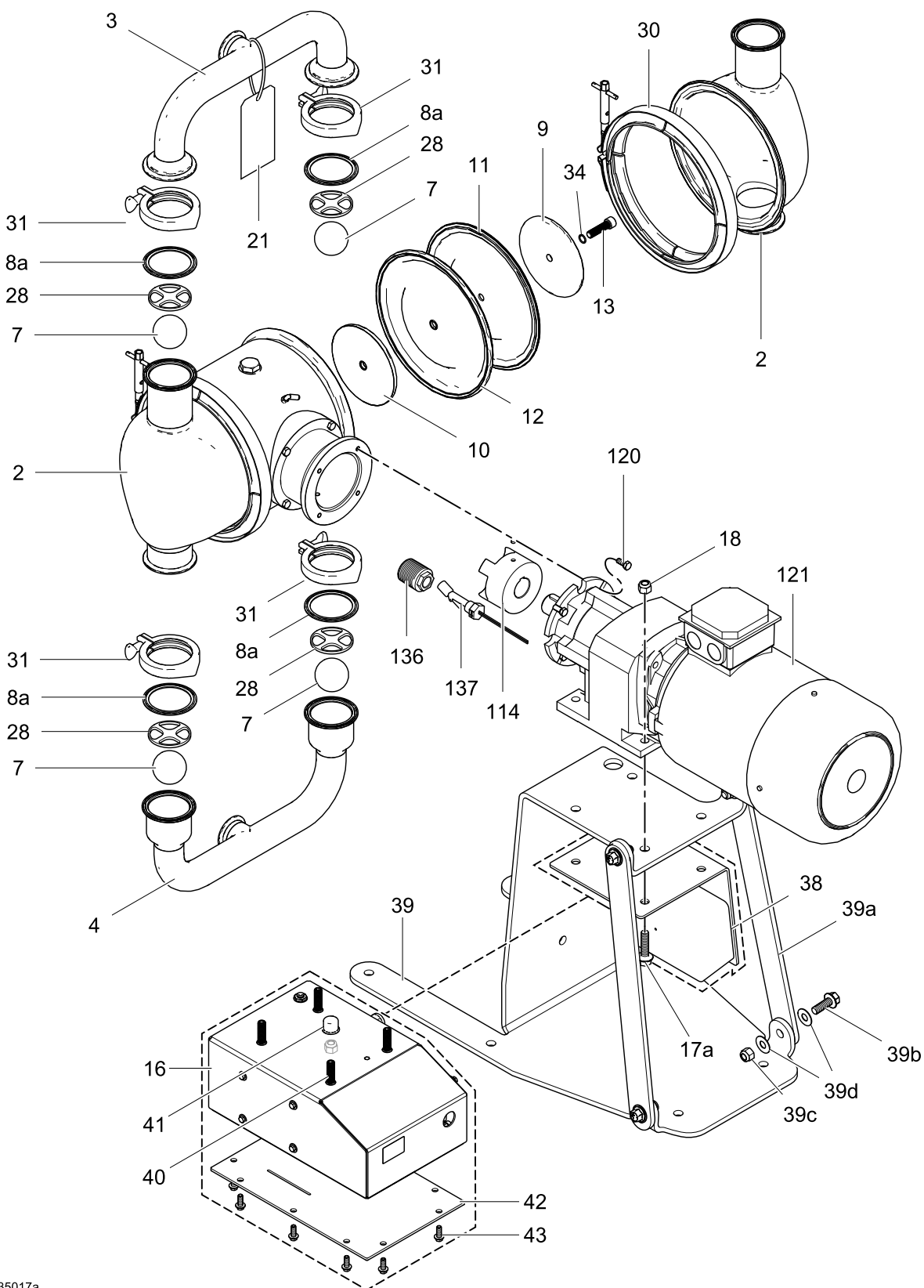

ti35017a

### 3000HS Flapper Pump

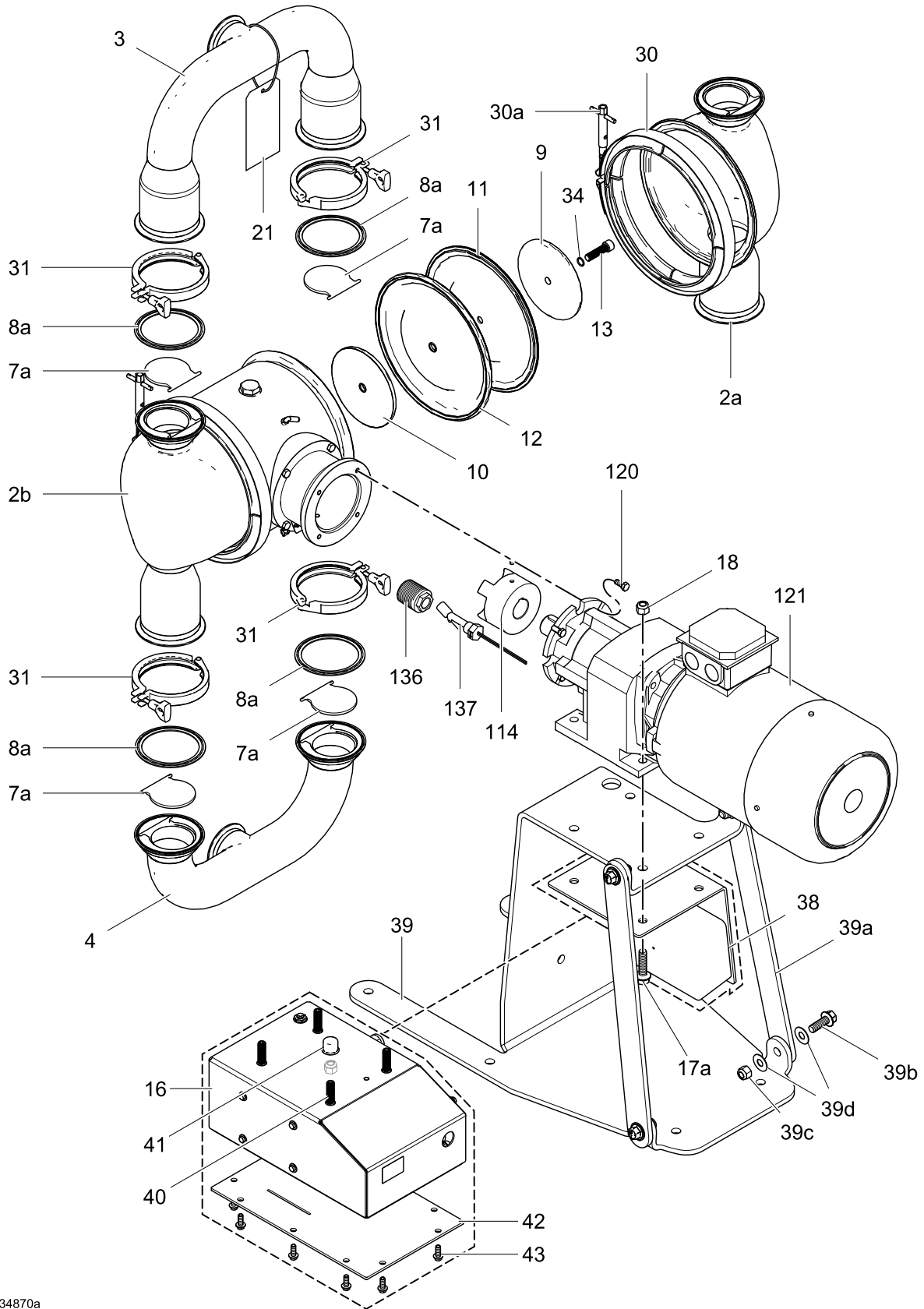

ti34870a

# 4000HS Flapper Pump

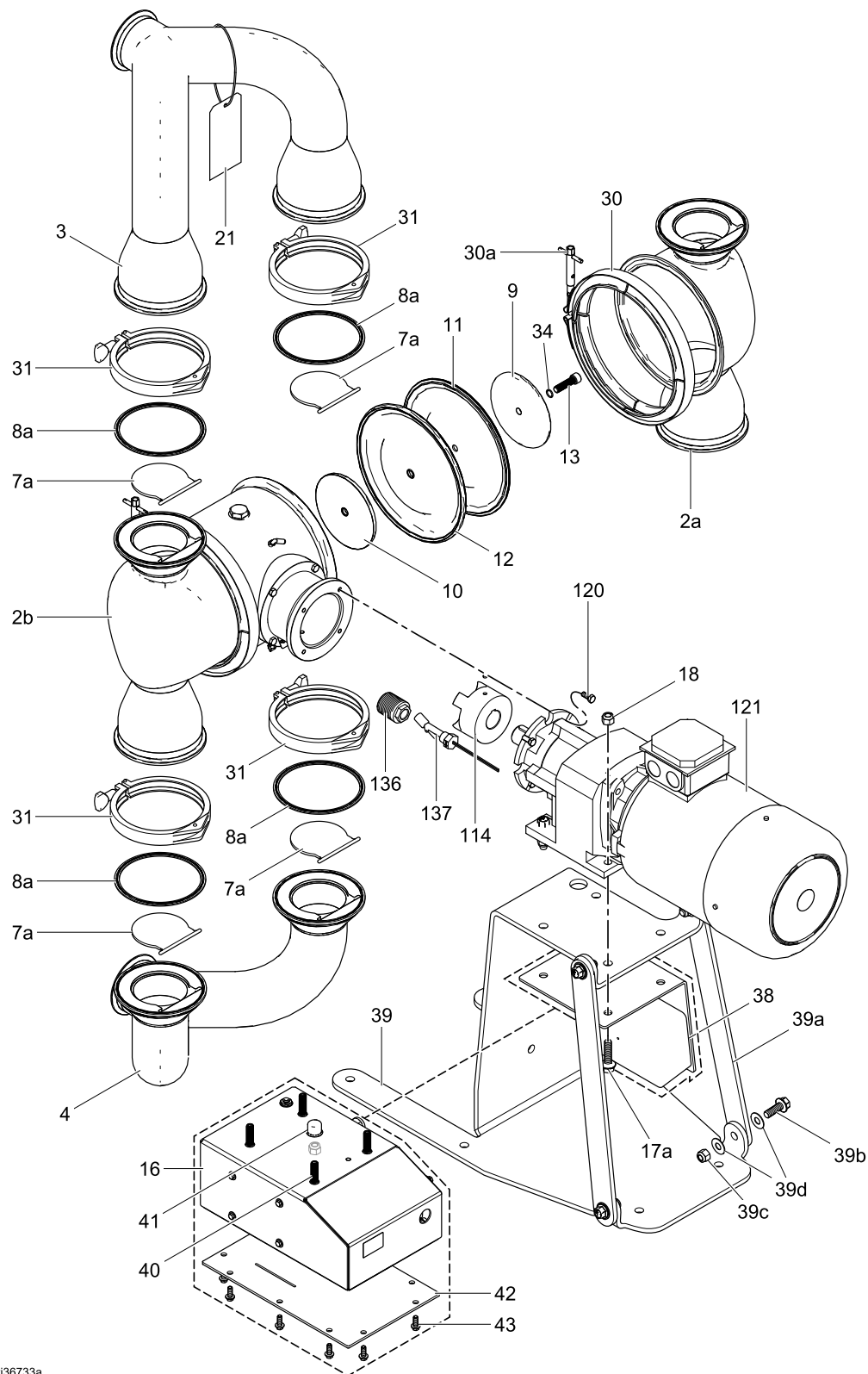

1136733a

## Parts/Kits Quick Reference

Use this table as a quick reference for parts/kits. Go to the pages indicated in the table for a full description of kit contents.

Ref.	Part	Kit	Description	Qty.
1	---	---	MODULE, drive; <i>See page 30.</i>	1
2	277264	---	COVER, fluid, SST	2
	---	25E575	2150FG	
	---	25P042	2150HS, 3A	
	---	---	2150PH	
2a	---	25E576	COVER, fluid, left, 3000HS	1
	---	25N998	COVER, fluid, left, 4000HS	1
2b	---	25E577	COVER, fluid, right, 3000HS	1
	---	25N999	COVER, fluid, right, 4000HS	1
3	277270	---	MANIFOLD, outlet; SST	1
	24U153	---	2150FG Flange	
	---	25E578	2150FG DIN	
	---	25P053	2150HS, 3A Tri-clamp	
	---	25E579	2150PH, Tri-clamp	
	---	25P025	3000HS flapper Tri-clamp	
	---	---	4000HS flapper Tri-clamp	
4	277269	---	MANIFOLD, inlet; SST	1
	24U152	---	2150FG Flange	
	---	25E580	2150FG DIN	
	---	25P052	2150HS, 3A Tri-clamp	
	---	25E581	2150PH, Tri-clamp	
	---	25P024	3000HS flapper Tri-clamp	
	---	---	4000HS flapper Tri-clamp	
6	15H826	---	SEAT	4
7	15B492	26C243	BALLS, kits are pkg of 4	4
	112359	26C241	Buna-N	
	112361	26C242	PTFE	
	15B491	26C569	Santoprene	
	15H834	26C244	FKM Fluoroelastomer	
	---	---	Polychloroprene weighted	
7a	---	25E582	CHECK VALVE, flapper, pkg of 4	1
	---	25P086	3000HS	
	---	---	4000HS	
8	15H831	---	O-RING,	4
	15H829	---	PTFE	
	---	---	EPDM	

Ref.	Part	Kit	Description	Qty.
8a	---	---	GASKET, sanitary, kits are pkg of 4, see page 37	1
9	189299	---	PLATE, fluid side; Stainless Steel; Not used with EO diaphragms	2
10	25B445	---	PLATE, air side	2
	---	25E583	2150FG	
	---	---	all other models, 2-pack	1
11	---	---	DIAPHRAGM, kit; <i>See page 32.</i>	1 kit
12	---	---	DIAPHRAGM, backup, <i>included with Ref. 11 where needed</i>	2
13	---	25B443	BOLT, shaft; Not used with EO diaphragms	2
15	---	25B421	BOLT, shaft; Not used with EO diaphragms	2
16	---	---	BRACKET, gear box, for 2150FG models without compressor; includes 4 each of refs 17 and 18	1
	---	25B431	COMPRESSOR, assembly; <i>includes Ref. 16a, 40, 41, 42, 43 where needed.</i>	1
	---	25B432	120 Volt	
	---	---	240 Volt	
16a	24Y544	---	COMPRESSOR	1
	24Y545	---	120 Volt	
	---	---	240 Volt	
17	EQ1519	25B421	BOLT, hex washer head, M8-1.25 x 32 mm	4
17a	---	25E586	SCREW kit, gear box, for all models except 2150FG, includes 4 each of Ref. 17a, 18	1
18	EQ1475	25B421 25E586	NUT	4
21	▲ 188621	---	LABEL, safety	1
	---	25P457	2150FG	
	---	---	all other models	
28	---	25E584	STOP, ball, 4-pack	1
30	15H513	---	CLAMP, sanitary, diaphragm	2
	15G323	---	2150FG	
	25P107	---	2150HS/3A/PH, 3000HS	
	---	---	4000HS	
30a	26C033	---	HANDLE, tee	2
31	15D475	---	CLAMP, sanitary	4
	---	---	2150 all models	



Ref.	Part	Kit	Description	Qty.
	510490	— — —	3000HS	
	16D245	— — —	4000HS	
32	198382		LABEL, safety, multilingual, 2150FG only	1
▲				
34	— — —	25B443	O-RING, for diaphragm shaft bolt; Not used with EO diaphragms	2
35	— — —	25B426	BRACKET, riser; <i>used for 2150FG models with a compressor; includes Ref 35a</i>	1
35a	— — —	25B426	BOLT, air compressor box, M8 x 1.25, 20mm	10
35b	17Z195	— — —	COVER, air compressor box, bottom, 2150HS/3A/PH, 3000HS, 4000HS	1
38	— — —	25E384	CONTROL, air, with bracket	1
39	— — —	25E585	BASE, mounting	1
39a	— — —	25E585	BRACE, mounting	2

Ref.	Part	Kit	Description	Qty.
39b	— — —	25E585	SCREW, flanged	4
39c	— — —	25E585	NUT, lock	4
39d	— — —	25E585	WASHER	8
40	— — —	— — —	SCREW, set, 1/2 X 2.25, pkg of 4	1
41	— — —	— — —	CAP, 3/4" nut, rigid	1
42	— — —	— — —	COVER, compressor box plate, <i>included with Ref. 16</i>	1
43	— — —	— — —	BOLT, hex head, M8 x 1.25 x 20mm, <i>included with Ref. 16</i>	10

— — — *Not sold separately.*

▲ *Replacement safety labels, signs, tags, and cards are available at no cost.*

## Center Section

Sample Configuration Number

Pump Model	Wetted Section Material	Drive	Center Section Material	Gear Box and Motor	Motor	Fluid Covers and Manifolds	Seats	Balls	Diaphragms	Manifold Seals	Certification
2150	FG	E	<b>A</b>	<b>04</b>	A	S13	SS	PT	PT	PT	21

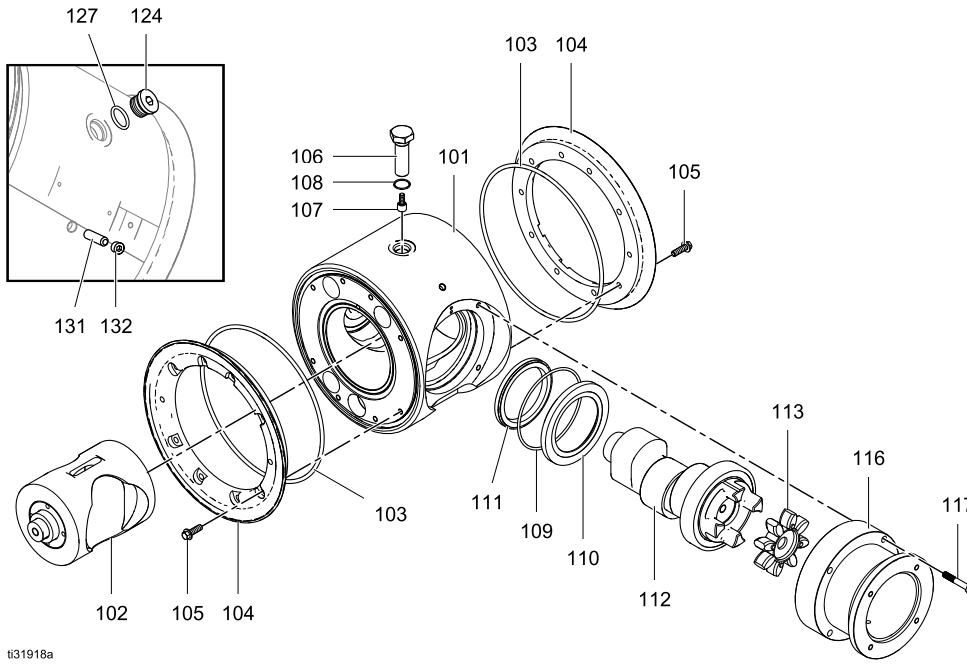

Ref	Part	Description	Qty
101	25B415 25B416	HOUSING, center, assembly; <i>includes plugs Aluminum (Axx) Stainless Steel (Sxx); also includes o-ring</i>	1
102	25B400	PISTON, assembly	1
103	— — —	O-RING, air cover; <i>included with ref 104</i>	2
104	25B442	AIR COVER, <i>includes refs 103, 105</i>	2
105	— — —	BOLT, air cover <i>included with ref 104</i>	16
106	25B419	BOLT, bearing; <i>includes Refs. 107 and 108 for aluminum center housing</i>	1
107	— — —	BEARING, cam follower. <i>included with Ref. 106</i>	1
108	— — —	O-RING, Size 019, Fluoroelastomer; <i>included with Ref. 106</i>	1
109†	— — —	O-RING, Size 153, Buna-N	1
110†	— — —	CARTRIDGE, seal	1
111†	— — —	SEAL, radial	1
112	25B414	SHAFT, drive, assembly; <i>includes o-ring (Ref. 109), cartridge (Ref. 110) and seal (Ref. 111)</i>	1
113	25B413	COUPLER, shaft	1
114	17S683	COUPLER, gearbox; <i>includes mounting hardware</i>	1
116	25B417 25B418	HOUSING, alignment, assembly; <i>includes screws (Refs. 117, 120) Aluminum (Axx) Stainless steel (Sxx)</i>	1
117	— — —	SCREW, socket head, M8 x 50 mm; <i>included with Ref. 116</i>	4
118	25B410 25B411 25B412	GEARBOX; <i>includes Ref 118a, 118b, 122</i> low speed medium speed high speed	1

Ref	Part	Description	Qty
118a	— — —	COUPLER; <i>included with Ref 118</i>	1
118b	— — —	KEY; <i>included with Ref 118</i>	1
120	— — —	SCREW, cap, hex head, M8 x 20 mm	4
121		MOTOR	1
	25B401	low speed gearmotor (24A, 25A, 26A)	
	25B402	medium speed gearmotor (14A, 15A, 16A)	
	25B403	high speed gearmotor (04A, 05A, 06A)	
	25B406	low speed ATEX (24C)	
	25B405	medium speed ATEX (14C)	
	25B404	high speed ATEX (04C)	
	25B409	low speed flameproof (24D)	
	25B408	medium speed flameproof (14D)	
	25B407	high speed flameproof (04D)	
122	— — —	SCREW, cap, 1/2–13 x 1.5 in.	4
124	24Y534	PLUG, front access <i>includes ref 127</i>	1
125	— — —	SCREW, ground, M5 x 0.8	1
127	— — —	O-RING <i>included with Ref 124</i>	1
130	— — —	ELBOW, 1/8–27 npt	1
131	— — —	PIN, stop, 5/16 x 1-1/4 in.	1
132	— — —	PLUG; 1/8-27 npt	1
135	189930	LABEL, caution	1
136	— — —	BUSHING <i>included with Ref 137</i>	
137	25B435	Leak sensor <i>includes Ref 136</i>	

— — — Not sold separately.

† Included in Shaft Seal Repair Kit 25B420.

## Diaphragms

Sample Configuration Number

Pump Model	Wetted Section Material	Drive	Center Section Material	Gear Box and Motor	Motor	Fluid Covers and Manifolds	Seats	Balls	Diaphragms	Manifold Seals	Certification
2150	FG	E	A	04	A	S13	SS	PT	<b>PT</b>	PT	21

Bolt-Through Diaphragm Kits	
For 2150FG	
<b>PT</b>	25B451
<b>SP</b>	25B452

For all HS, 3A, PH models	
<b>BN</b>	253223
<b>FK</b>	25P268
<b>PS</b>	25P266
<b>SP</b>	25B452

Kits include:

- 2 diaphragms (11)
- 2 backers (12), if applicable
- 1 packet anaerobic adhesive
- 2 o-rings

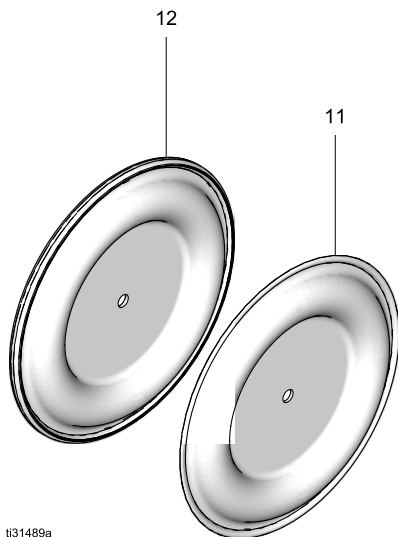

ti31489a

Overmolded Diaphragm Kit	
For all HS, 3A, PH models	
<b>EO</b>	25P270

Kits include:

- 2 diaphragms (11) with set screw (13)

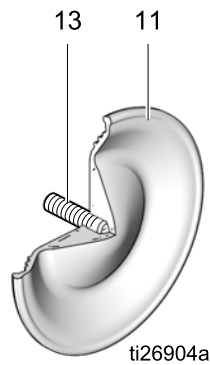

ti26904a

## Sanitary Gasket Kits

Size	Part No.	Material
2150	25R602	Buna-N
	25P063	EPDM
	26A892	FKM
	26A915	PTFE/EPDM Bonded*
3000	25R603	Buna-N
	25P064	EPDM
	26A893	FKM
	26A916	PTFE/EPDM Bonded*
4000	25R605	Buna-N
	25P066	EPDM
	26A895	FKM
	26A918	PTFE/EPDM Bonded*

\* PTFE/EPDM option offered as replacement only.

Kit descriptions appear in the following order: *Pump model, seat material, ball material, diaphragm material, gasket material*. For example, 2150HS-PH --,CW,EO,EP. Refer to [Configuration Number Matrix for 2150 FG Pumps, page 6](#), and [Configuration Number Matrix for 2150, 3000, and 4000 HS Pumps, page 8](#), to define components.

## Fluid Section Repair Kits

Kit	Description
25R698	2150HS-PH --,BN,BN,BN
25R699	2150HS-PH --,CW,EO,EP
25R707	2150HS-PH --,CW,FK,FK
25R709	2150HS-PH --,EP,EO,EP
25R712	2150HS-PH --,FK,FK,FK
25R713	2150HS-PH --,PT,EO,EP
25R715	2150HS-PH --,PT,PS,EP
25R720	3250HS FL,--,BN,BN
25R721	3250HS FL,--,EO,EP
25R722	3250HS FL,--,FK,FK
25R724	3250HS FL,--,PS,EP
25R727	4150HS FL,--,BN,BN
25R728	4150HS FL,--,EO,EP
25R729	4150HS FL,--,FK,FK
25R731	4150HS FL,--,PS,EP
25T463	2150E HS-PH --,CW,SP,EP
25T464	2150E HS-PH --,EP,SP,EP
25T465	2150E HS-PH --,PT,SP,EP
25T466	2150E HS-PH --,SP,SP,EP
25T468	3000E HS FL,--,SP,EP
25T470	4000E HS FL,--,SP,EP

Kits include:

- 4 balls or flapper valves (7 or 7a)
- 2 diaphragms (11)
- 2 diaphragm backers (12), if applicable
- 4 gaskets (8a)
- 1 packet anaerobic adhesive, if applicable
- 2 o-rings (34), (for all diaphragms except EO)

## Kits and Accessories

### Center Section Repair Tool Kit 25B434

Includes tools needed to remove the bearing from the center section.

### Bearing Puller Kit 17J718

Includes an interchangeable bearing puller set.

### Dual Inlet and Dual Outlet

To convert to a dual inlet or outlet, the following parts are required:

Dual Inlet:			
Ref.	Part/Kit	Description	Qty.
45	25P084	SEAT, flapper, SP3F	2
	25P085	SEAT, flapper, SP4F	2
47	25P065	GASKET, EPDM, SP3R	2
	25P067	GASKET, EPDM, SP4F	2
48	15D475	CLAMP, flapper, SP3F	2
	510490	CLAMP, flapper, SP4F	2
Dual Outlet:			
46	25P082	CHAMBER, flapper, SP3F	2
	25P083	CHAMBER, flapper, SP4F	2
47	25P065	GASKET, EPDM, SP3R	2
	25P067	GASKET, EPDM, SP4F	2
48	15D475	CLAMP, flapper, SP3F	2
	510490	CLAMP, flapper, SP4F	2

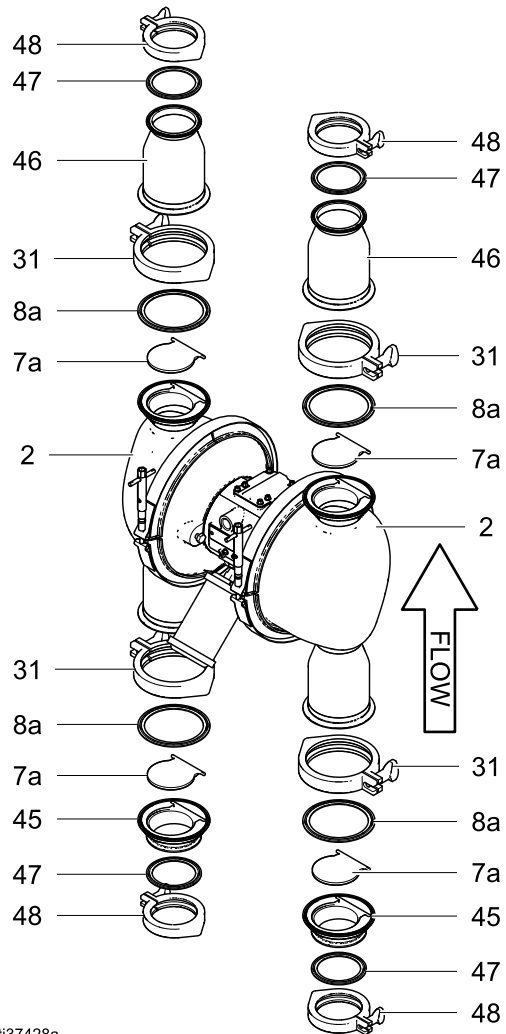

ti37428a

# Technical Specifications

SaniForce Electric Double Diaphragm Pump		
	US	Metric
Maximum fluid working pressure		
2150	100 psi	0.69 MPa, 6.9 bar
3000HS, 4000HS	60 psi	0.41 MPa, 4.1 bar
Air pressure operating range		
2150	20 to 100 psi	0.14 to 0.69 MPa, 1.4 to 6.9 bar
3000HS, 4000HS	20 to 60 psi	0.14 to 0.41 MPa, 1.4 to 4.1 bar
Air inlet size	3/8 in. npt(f)	
Air Consumption		
120V Compressor	< 0.8 cfm	< 22.1 lpm
240V Compressor	< 0.7 cfm	< 19.5 lpm
Maximum size pumpable solids		
2150FG, 2 in. balls	0.25 in.	6.3 mm
2150HS/3A/PH	0.5 in.	12.7 mm
3000HS, 3 in. flapper	2.5 in.	62.5 mm
4000HS, 4 in. flapper	3.8 in.	96.5 mm
Minimum ambient air temperature for operation and storage. <b>NOTE:</b> Exposure to extreme low temperatures may result in damage to plastic parts.	32° F	0° C
Fluid displacement per cycle (free-flow)		
2150	0.6 gallons	2.3 liters
3000HS, 4000HS	0.4 gallons	1.5 liters
Maximum free-flow delivery (continuous duty)		
2150	100 gpm	378 lpm
3000HS	56 gpm	212 lpm
4000HS	52 gpm	197 lpm
Maximum pump speed (continuous duty)	60 Hz/160 cpm	
<b>Fluid Inlet and Outlet Size</b>		
2150FG, Stainless Steel	2.5 in. or 65 mm DIN 11851 sanitary connection	
2150HS, 3A, PH	2 in. or 50 mm DIN 11851 sanitary connection	
3000HS, Stainless Steel	3 in. or 80 mm DIN 11851 sanitary connection	
4000HS, Stainless Steel	4 in. or 100 mm DIN 11851 100 sanitary connection	
<b>Electric Motor</b>		
AC, Standard CE (04A, 05A (not CE), 06A)		
Power	7.5 HP	5.5 kW
Number of Motor Poles	4-Pole	
Speed	1800 rpm (60 Hz) or 1500 rpm (50 Hz)	
Constant Torque	6:1	
Gear Ratio	11.25	

Technical Specifications

Voltage	3-phase 230V / 3-Phase 460V	
Maximum Amperage Load	19.5 A (230V) / 9.75 A (460V)	
IE Rating	IE3	
IP Rating	IP55	
AC, Standard CE (14A, 15A (not CE), 16A)		
Power	5.0 HP	3.7 kW
Number of Motor Poles	4-Pole	
Speed	1800 rpm (60 Hz) or 1500 rpm (50 Hz)	
Constant Torque	6:1	
Gear Ratio	16.46	
Voltage	3-phase 230V / 3-Phase 460V	
Maximum Amperage Load	13.0 A (230V) / 6.5 A (460V)	
IP Rating	IP55	
AC, Standard CE (24A, 25A (not CE), 26A)		
Power	3.0 HP	2.2 kW
Number of Motor Poles	4-Pole	
Speed	1800 rpm (60 Hz) or 1500 rpm (50 Hz)	
Constant Torque	6:1	
Gear Ratio	26.77	
Voltage	3-phase 230V / 3-Phase 460V	
Maximum Amperage Load	7.68 A (230V) / 3.84 A (460V)	
IE Rating	IE3	
IP Rating	IP55	
AC, ATEX (04C)		
Power	7.5 HP	5.5 kW
Number of Motor Poles	4-Pole	
Speed	1800 rpm (60 Hz) or 1500 rpm (50 Hz)	
Constant Torque	6:1	
Gear Ratio	11.88	
Voltage	3-phase 240V / 3-Phase 415V	
Maximum Amperage Load	20 A (230V) / 11.5 A (460V)	
IP Rating	IP56	
AC, ATEX (14C)		
Power	5.0 HP	4.0 kW
Number of Motor Poles	4-Pole	
Speed	1800 rpm (60 Hz) or 1500 rpm (50 Hz)	
Constant Torque	6:1	
Gear Ratio	16.46	
Voltage	3-phase 240V / 3-Phase 415V	
Maximum Amperage Load	14.7 A (230V) / 8.5 A (460V)	
IP Rating	IP56	
AC, ATEX (24C)		
Power	3.0 HP	2.2 kW



Number of Motor Poles	4-Pole	
Speed	1800 rpm (60 Hz) or 1500 rpm (50 Hz)	
Constant Torque	6:1	
Gear Ratio	26.77	
Voltage	3-phase 240V / 3-Phase 415V	
Maximum Amperage Load	8.5 A (230V) / 5.0 A (460V)	
IP Rating	IP56	
<b>AC, Explosionproof (04D)</b>		
Power	7.5 HP	5.5 kW
Number of Motor Poles	4-Pole	
Speed	1800 rpm (60 Hz) or 1500 rpm (50 Hz)	
Constant Torque	6:1	
Gear Ratio	11.88	
Voltage	3-phase 230V / 3-Phase 460V	
Maximum Amperage Load	20.0 A (230V) / 10.0 A (460V)	
IP Rating	IP54	
<b>AC, Explosionproof (14D)</b>		
Power	5.0 HP	3.7 kW
Number of Motor Poles	4-Pole	
Speed	1800 rpm (60 Hz) or 1500 rpm (50 Hz)	
Constant Torque	6:1	
Gear Ratio	16.46	
Voltage	3-phase 230V / 3-Phase 460V	
Maximum Amperage Load	13.0 A (230V) / 6.5 A (460V)	
IP Rating	IP55	
<b>AC, Explosionproof (24D)</b>		
Power	3.0 HP	2.2 kW
Number of Motor Poles	4-Pole	
Speed	1800 rpm (60 Hz) or 1500 rpm (50 Hz)	
Constant Torque	6:1	
Gear Ratio	26.77	
Voltage	3-phase 230V / 3-Phase 460V	
Maximum Amperage Load	8 A (230V) / 4 A (460V)	
IP Rating	IP54	
<b>Leak Sensor</b>		
<b>Contact Ratings:</b>		
State	Normally closed	
Voltage	240V Max (AC/DC)	
Current	0.28 A max at 120 VAC 0.14 A max at 240 VAC 0.28 A max at 24 VDC 0.07 A max at 120 VDC	
Power	30 W max	
Ambient Temperature	-20° to 40°C (-4° to 104°F)	

Technical Specifications

Ex Ratings:	
Classification: "simple apparatus" in accordance with UL/EN/IEC 60079-11, clause 5.7	
Class I, Group D, Class II, Group F&G, Temp Code T3B	
	
II 2 G Ex ib IIC T3	
Parameters	$U_i = 24 \text{ V}$ $I_i = 280 \text{ mA}$ $P_i = 1.3 \text{ W}$ $C_i = 2.4 \text{ pF}$ $L_i = 1.00 \text{ }\mu\text{H}$
<b>Noise Data</b>	
Sound Power (measured per ISO-9614-2)	
at 90 psi fluid pressure and 80 cpm	84 dBa
at 60 psi fluid pressure and 160 cpm (full flow)	92 dBa
Sound Pressure [tested 3.28 ft (1 m) from equipment]	
at 90 psi fluid pressure and 80 cpm	74 dBa
at 60 psi fluid pressure and 160 cpm (full flow)	82 dBa
<b>Wetted Parts</b>	
Wetted parts include material(s) chosen for seat, ball, and diaphragm options, <b>plus the pump's material of construction: Aluminum, Polypropylene, Stainless Steel, Conductive Polypropylene, or PVDF</b>	
<b>Non-wetted parts</b>	
Non-wetted parts include aluminum, coated carbon steel, PTFE, stainless steel, polypropylene	

### Pump Weights

Model	Pump Material	Motor/Gearbox																			
	Center Section	Standard AC						ATEX AC						Flameproof AC						No Gear-motor	
		04A		14A		24A		04C		14C		24C		04D		14D		24D		94G	
		lb	kg	lb	kg	lb	kg	lb	kg	lb	kg	lb	kg	lb	kg	lb	kg	lb	kg	lb	kg
2150FG	Aluminum	360	163	328	149	308	139	475	215	351	159	325	147	517	234	427	194	418	190	217	98
	Stainless Steel	442	200	410	186	390	177	557	253	433	196	407	185	599	271	509	231	500	227	299	136
2150HS- /3A/PH	Aluminum	358	162	326	148	306	139	473	215	349	158	323	146	515	234	425	193	416	189	215	98
	Stainless Steel	440	200	408	185	388	176	555	252	431	195	405	184	597	271	507	230	498	226	297	135
3000HS	Aluminum	365	166	333	151	313	142	480	218	356	161	330	150	522	237	432	196	423	192	222	101
	Stainless Steel	447	203	415	188	395	179	562	255	438	199	412	187	604	274	514	233	505	229	304	138
4000HS	Aluminum	407	185	375	170	355	161	522	237	398	180	372	169	564	256	474	215	465	211	264	120
	Stainless Steel	489	222	457	207	437	198	604	274	480	218	454	206	646	293	556	252	547	248	346	157

Variable Frequency Drives (2 hp)

Model	Hp/kW	Input Voltage Range	Nominal Output Voltage †
17K696	3.0/2.2	170–264 Vac	208–240 Vac, 3 phase
17K697	3.0/2.2	340–528 Vac	400–480 Vac, 3 phase
25B446	5.0/4.0	170–264 Vac	208–240 Vac, 3 phase
25B447	5.0/4.0	340–528 Vac	400–480 Vac, 3 phase
25B448	7.5/5.5	170–264 Vac	208–240 Vac, 3 phase
25B449	7.5/5.5	340–528 Vac	400–480 Vac, 3 phase

† Output voltage is dependent on input voltage.

Component/Model	U.S.	Metric
Compressor	28 lb	13 kg

### Fluid Temperature Range

<b>NOTICE</b>
Temperature limits are based on mechanical stress only. Certain chemicals will further limit the fluid temperature range. Stay within the temperature range of the most-restricted wetted component. Operating at a fluid temperature that is too high or too low for the components of your pump may cause equipment damage.

Diaphragm/Ball/Seat Material	Stainless Steel Pump Fluid Temperature Range	
	Fahrenheit	Celsius
Polychloroprene check balls (CW)	14° to 176°F	-10° to 80°C
PTFE check balls or two-piece PTFE/EPDM diaphragm (PT)	-40° to 220°F	-40° to 104°C
Buna-N check balls (BN)	10° to 180°F	-12° to 82°C
FKM Fluoroelastomer check balls (FK)*	-40° to 275°F	-40° to 135°C
2-piece PTFE/Santoprene diaphragm (PS)	40° to 180°F	4° to 82°C
Santoprene check balls or 2-piece diaphragm (SP)	-40° to 180°F	-40° to 82°C
EPDM overmolded diaphragm (EO)	-40° to 250°F	-40° to 121°C

\* The maximum temperature listed is based on the ATEX standard for T3 temperature classification.

# California Proposition 65

## CALIFORNIA RESIDENTS

 **WARNING:** Cancer and reproductive harm — [www.P65warnings.ca.gov](http://www.P65warnings.ca.gov).

# Notes

# Graco Standard Warranty

Graco warrants all equipment referenced in this document which is manufactured by Graco and bearing its name to be free from defects in material and workmanship on the date of sale to the original purchaser for use. With the exception of any special, extended, or limited warranty published by Graco, Graco will, for a period of twelve months from the date of sale, repair or replace any part of the equipment determined by Graco to be defective. This warranty applies only when the equipment is installed, operated and maintained in accordance with Graco's written recommendations.

This warranty does not cover, and Graco shall not be liable for general wear and tear, or any malfunction, damage or wear caused by faulty installation, misapplication, abrasion, corrosion, inadequate or improper maintenance, negligence, accident, tampering, or substitution of non-Graco component parts. Nor shall Graco be liable for malfunction, damage or wear caused by the incompatibility of Graco equipment with structures, accessories, equipment or materials not supplied by Graco, or the improper design, manufacture, installation, operation or maintenance of structures, accessories, equipment or materials not supplied by Graco.

This warranty is conditioned upon the prepaid return of the equipment claimed to be defective to an authorized Graco distributor for verification of the claimed defect. If the claimed defect is verified, Graco will repair or replace free of charge any defective parts. The equipment will be returned to the original purchaser transportation prepaid. If inspection of the equipment does not disclose any defect in material or workmanship, repairs will be made at a reasonable charge, which charges may include the costs of parts, labor, and transportation.

**THIS WARRANTY IS EXCLUSIVE, AND IS IN LIEU OF ANY OTHER WARRANTIES, EXPRESS OR IMPLIED, INCLUDING BUT NOT LIMITED TO WARRANTY OF MERCHANTABILITY OR WARRANTY OF FITNESS FOR A PARTICULAR PURPOSE.**

Graco's sole obligation and buyer's sole remedy for any breach of warranty shall be as set forth above. The buyer agrees that no other remedy (including, but not limited to, incidental or consequential damages for lost profits, lost sales, injury to person or property, or any other incidental or consequential loss) shall be available. Any action for breach of warranty must be brought within two (2) years of the date of sale..

**GRACO MAKES NO WARRANTY, AND DISCLAIMS ALL IMPLIED WARRANTIES OF MERCHANTABILITY AND FITNESS FOR A PARTICULAR PURPOSE, IN CONNECTION WITH ACCESSORIES, EQUIPMENT, MATERIALS OR COMPONENTS SOLD BUT NOT MANUFACTURED BY GRACO.** These items sold, but not manufactured by Graco (such as electric motors, switches, hose, etc.), are subject to the warranty, if any, of their manufacturer. Graco will provide purchaser with reasonable assistance in making any claim for breach of these warranties..

In no event will Graco be liable for indirect, incidental, special or consequential damages resulting from Graco supplying equipment hereunder, or the furnishing, performance, or use of any products or other goods sold hereto, whether due to a breach of contract, breach of warranty, the negligence of Graco, or otherwise.

## FOR GRACO CANADA CUSTOMERS

The Parties acknowledge that they have required that the present document, as well as all documents, notices and legal proceedings entered into, given or instituted pursuant hereto or relating directly or indirectly hereto, be drawn up in English. Les parties reconnaissent avoir convenu que la rédaction du présente document sera en Anglais, ainsi que tous documents, avis et procédures judiciaires exécutés, donnés ou intentés, à la suite de ou en rapport, directement ou indirectement, avec les procédures concernées.

## Graco Information

For the latest information about Graco products, visit [www.graco.com](http://www.graco.com).  
For patent information, see [www.graco.com/patents](http://www.graco.com/patents).

**To place an order**, contact your Graco Distributor or call to identify the nearest distributor.

**Phone:** 612-623-6921 **or Toll Free:** 1-800-328-0211 **Fax:** 612-378-3505

All written and visual data contained in this document reflects the latest product information available at the time of publication.

Graco reserves the right to make changes at any time without notice.  
Original Instructions. This manual contains English. MM 3A5133

**Graco Headquarters:** Minneapolis  
**International Offices:** Belgium, China, Japan, Korea

**GRACO INC. AND SUBSIDIARIES • P.O. BOX 1441 • MINNEAPOLIS MN 55440-1441 • USA**  
**Copyright 2017, Graco Inc. All Graco manufacturing locations are registered to ISO 9001.**

[www.graco.com](http://www.graco.com)  
Revision M, June 2021