

PR70™ and PR70v™ Feed Systems

312394ZAG
EN

Fixed or variable ratio systems. For accurate metering, mixing, and dispensing of two-component materials. For professional use only.

Not approved for use in European explosive atmosphere locations.

*3000 psi (21 MPa, 207 bar) Maximum Working Pressure
100 psi (0.7 MPa, 7 bar) Maximum Air Inlet Pressure*



Important Safety Instructions

Read all warnings and instructions in all supplied manuals. Save these instructions.

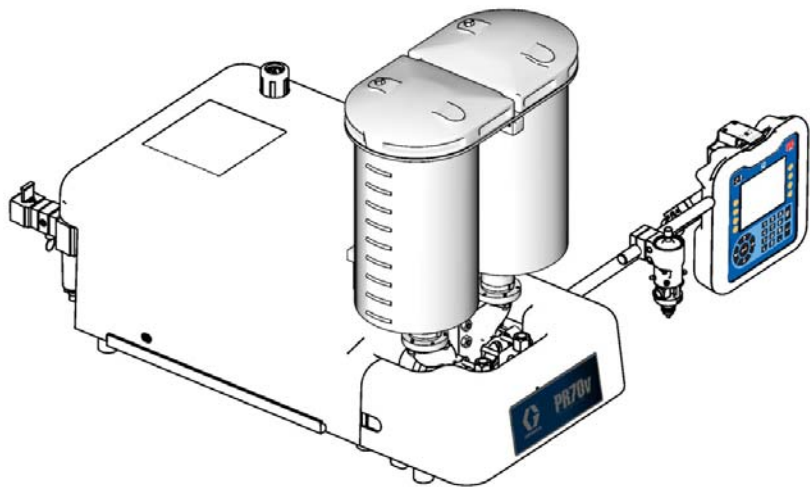

ti12580b

*PR70v shown with Polyethylene Tanks and
Advanced Display Module*



Contents

Related Manuals 2

Product Configurator 3

Warnings 10

 Moisture Sensitivity of Isocyanates 12

Grounding 13

Installation 14

 Polyethylene Tank Lid with Agitator 14

 Pneumatic Agitator Motor 15

 Level Sensors 15

 Auto-Refill Installation 17

 Pressure Transducer and Flow Meter Installation 17

Startup 18

Pressure Relief Procedure 19

 Models with Advanced Display Module 19

 Models with Standard Display Module 19

Setup 20

 Level Sensor Calibration 20

 Vacuum De-gas 21

 Vacuum De-gas and Vacuum Auto-Fill 22

 Accumulator Filling 23

Shutdown 24

Repair 25

 Tank Removal 25

 Ball Valve Removal from Tank 25

 Ball Valve Repair 26

 Agitator Fuse Replacement 26

Parts 27

 Accumulator, 25B196 27

 8 Liter Polyethylene Tanks 30

 Polyethylene Tank Agitators 32

 On-Board Stainless Steel Tanks 37

 Ball Valve, Assembly 255280 40

 Flange Assembly, 256896 41

 On-Board Stainless Steel Tank Lids 42

 Tanks for Use with Dust Covers 44

 Tanks for Use with Clampdown Covers 44

 Off-Board Stainless Steel Tanks 46

 Off-Board Stainless Steel Tank Lids 49

 Vacuum Tree Manifold, 255342 58

 Vacuum Tree Manifold, 257746 58

 Stainless Steel Tank Agitators 60

 Level Sensors 66

Kits 68

Dimensions 70

 Machine with On-Board Tanks 70

 Machine with Off-Board Tanks 71

Technical Data 73

Graco Standard Warranty 74

Graco Information 74

Related Manuals

PR70 and PR70v Operation and Parts Manuals	
Part	Description
3A0429	PR70™ with Standard Display Module Operation and Maintenance Manual
312759	PR70 and PR70v™ with Advanced Display Module Operation and Maintenance Manual
312760	PR70 and PR70v Repair and Parts Manual
312761	PR70v Integrated Heat Instructions - Parts Manual
334984	PR70f™ with Flow Control Operation and Maintenance Manual
3A6225	PR70f Conversion Kit Instructions - Parts Manual
MD2 Dispense Valve Manual	
Part	Description
312185	MD2 Dispense Valve Instructions and Parts Manual

Product Configurator

PR7F	-	-	-	-	-	-	-	-	-	-	-	-	-	-	-	-	-	-	-
Code:	A	B-C	D-E	F	G-H	I-J	K	L	M	N	O	P	Q	R	S	T	U	V	
	Air Motor	High Volume Side Piston	Low Volume Side Piston	Controls	High Volume Side Hose	Low Volume Side Hose	Dispense Valve	Mixer	Applicator Mounting	Power Cord	Flow Monitoring	High Volume Side Tank	High Volume Side Tank Cover	Low Volume Side Tank	Low Volume Side Tank Cover	Tank Level Sensors	Heat Zone Controller	Off-Board Tank Stand	

An example of the product configurator would be the following configurator code.

PR7F	-	J	-	A5	-	A5	-	E	-	A6	-	A6	-	3	-	1	-	2	-	A	-	N	-	3	-	N	-	H	-	N	-	6	-	N	-	N
Code:	A	B-C	D-E	F	G-H	I-J	K	L	M	N	O	P	Q	R	S	T	U	V																		
	Air Motor	High Volume Side Piston	Low Volume Side Piston	Controls	High Volume Side Hose	Low Volume Side Hose	Dispense Valve	Mixer	Applicator Mounting	Power Cord	Flow Monitoring	High Volume Side Tank	High Volume Side Tank Cover	Low Volume Side Tank	Low Volume Side Tank Cover	Tank Level Sensors	Heat Zone Controller	Off-Board Tank Stand																		

The following part number fields apply for the PR70 and PR70v part numbering configurator fields. Shaded items listed in the configurator table below are “Super Standard” items that are typically stocked and provide the best delivery dates.

Code A	Part	Air Motor
A	LC0262	PR70 with 3.0 in. (4.56 mm) Air Motor
B	LC0264	PR70 with 4.5 in. (10.26 mm) Air Motor
C	LC0263	PR70 with 3.0 in. (4.56 mm) Air Motor and Hydracheck
D	LC0265	PR70 with 4.5 in. (10.26 mm) Air Motor and Hydracheck
F	LC0242	PR70v with 3.0 in. (4.56 mm) Air Motor
G	LC0244	PR70v with 4.5 in. (10.26 mm) Air Motor
H	LC0243	PR70v with 3.0 in. (4.56 mm) Air Motor and Hydracheck
J	LC0245	PR70v with 4.5 in. (10.26 mm) Air Motor and Hydracheck

Code B	Part	High Volume Side Piston and Metering Tube Material
A	LC1__	Nylon Piston, Stainless Steel Metering Tube (last three digits of part number is the mm ² piston size)
B	LC2__	UHMWPE Piston, Stainless Steel Metering Tube (last three digits of part number is the mm ² piston size)
C	LC3__	UHMWPE Piston, Ceramic Metering Tube (last three digits of part number is the mm ² piston size)
Code C	Part	High Volume Piston Size (mm ²)
1		80, Available in Nylon Only
2		100, Available in Nylon Only
3		120, Available in Nylon Only

4		140, Available in Nylon Only
5		160
6		180
7		200
8		220
9		240
A		260
B		280
C		300
F		320
G		360
H		400
J		440
L		480
M		520
R		560
S		600
T		640
U		720
W		800
X		880
Y		960
Z		Custom High Volume side, consult factory (stainless steel only)
Low Volume Side Piston and Metering Tube Material		
Code D	Part	
A	LC1___	Nylon Piston, Stainless Steel Metering Tube (last three digits of part number is the mm ² piston size)
B	LC2___	UHMWPE Piston, Stainless Steel Metering Tube (last three digits of part number is the mm ² piston size)
C	LC3___	UHMWPE Piston, Ceramic Metering Tube (last three digits of part number is the mm ² piston size)
Low Volume Side Piston Size (mm ²)		
Code E	Part	
1		80, Available in Nylon Only
2		100, Available in Nylon Only
3		120, Available in Nylon Only
4		140, Available in Nylon Only
5		160
6		180
7		200
8		220
9		240
A		260
B		280
C		300
F		320
G		360
H		400

J		440
L		480
M		520
R		560
S		600
T		640
U		720
W		800
X		880
Y		960
Z		Custom Low Volume side, consult factory (stainless steel only)
Code F Part Controls		
B	LC0272	Standard Display Module with 1 Fluid Control Module
D	LC0274	Advanced Display Module with 1 Fluid Control Module
E	LC0275	Advanced Display Module with 2 Fluid Control Modules
Codes G-H, I-J High Volume Hose / Low Volume Hose		
	Part	
A1	LC0801	3/16 in. (4.8 mm) - 2.5 ft (0.6 m)
A2	LC0802	3/16 in. (4.8 mm) - 10 ft (3.0 m)
A3	LC0803	3/16 in. (4.8 mm) - 15 ft (4.6 m)
A4	LC0804	1/4 in. (6.5 mm) - 2.5 ft (0.6 m)
A5	LC0805	1/4 in. (6.5 mm) - 10 ft (3.0 m)
A6	LC0806	1/4 in. (6.5 mm) - 15 ft (4.6 m)
A7	LC0807	3/8 in. (9.5 mm) - 2.5 ft (0.6 m)
A8	LC0808	3/8 in. (9.5 mm) - 10 ft (3.0 m)
A9	LC0809	3/8 in. (9.5 mm) - 15 ft (4.6 m)
AA	LC0810	1/2 in. (13 mm) - 2.5 ft (0.6 m)
AB	LC0811	1/2 in. (13 mm) - 10 ft (3.0 m)
AC	LC0812	1/2 in. (13 mm) - 15 ft (4.6 m)
AG	LC0813	3/4 in. (19 mm) - 10 ft (3.0 m)
AH	LC0814	3/4 in. (19 mm) - 15 ft (4.6 m)
B4	LC0881	Heated, 1/4 in. (6.5 mm) - 2.5 ft (0.6 m)
B5	LC0882	Heated, 1/4 in. (6.5 mm) - 10 ft (3.0 m)
B6	LC0883	Heated, 1/4 in. (6.5 mm) - 15 ft (4.6 m)
B7	LC0884	Heated, 3/8 in. (9.5 mm) - 2.5 ft (0.6 m)
B8	LC0885	Heated, 3/8 in. (9.5 mm) - 10 ft (3.0 m)
B9	LC0886	Heated, 3/8 in. (9.5 mm) - 15 ft (4.6 m)
BA	LC0887	Heated, 1/2 in. (13 mm) - 2.5 ft (0.6 m)
BB	LC0888	Heated, 1/2 in. (13 mm) - 10 ft (3.0 m)
BC	LC0889	Heated, 1/2 in. (13 mm) - 15 ft (4.6 m)
BG	LC0890	Heated, 3/4 in. (19 mm) - 10 ft (3.0 m)
BH	LC0891	Heated, 3/4 in. (19 mm) - 15 ft (4.6 m)
C1	LC0161	Recirculating, On-Board Tanks, 3/16 in. (4.8 mm) - 2.5 ft (0.6 m)
C2	LC0162	Recirculating, On-Board Tanks, 3/16 in. (4.8 mm) - 10 ft (3.0 m)

C3	LC0163	Recirculating, On-Board Tanks, 3/16 in. (4.8 mm) - 15 ft (4.6 m)
C4	LC0164	Recirculating, On-Board Tanks, 1/4 in. (6.5 mm) - 2.5 ft (0.6 m)
C5	LC0165	Recirculating, On-Board Tanks, 1/4 in. (6.5 mm) - 10 ft (3.0 m)
C6	LC0166	Recirculating, On-Board Tanks, 1/4 in. (6.5 mm) - 15 ft (4.6 m)
C7	LC0167	Recirculating, On-Board Tanks, 3/8 in. (9.5 mm) - 2.5 ft (0.6 m)
C8	LC0168	Recirculating, On-Board Tanks, 3/8 in. (9.5 mm) - 10 ft (3.0 m)
C9	LC0169	Recirculating, On-Board Tanks, 3/8 in. (9.5 mm) - 15 ft (4.6 m)
CA	LC0170	Recirculating, On-Board Tanks, 1/2 in. (13 mm) - 2.5 ft (0.6 m)
CB	LC0171	Recirculating, On-Board Tanks, 1/2 in. (13 mm) - 10 ft (3.0 m)
CC	LC0172	Recirculating, On-Board Tanks, 1/2 in. (13 mm) - 15 ft (4.6 m)
CD	LC0173	Recirculating, On-Board Tanks, 3/4 in. (19 mm) - 10 ft (3.0 m)
CE	LC0174	Recirculating, On-Board Tanks, 3/4 in. (19 mm) - 15 ft (4.6 m)
D1	LC0175	Recirculating, Off-Board Tanks, 3/16 in. (4.8 mm) - 2.5 ft (0.6 m)
D2	LC0176	Recirculating, Off-Board Tanks, 3/16 in. (4.8 mm) - 10 ft (3.0 m)
D3	LC0177	Recirculating, Off-Board Tanks, 3/16 in. (4.8 mm) - 15 ft (4.6 m)
D4	LC0178	Recirculating, Off-Board Tanks, 1/4 in. (6.5 mm) - 2.5 ft (0.6 m)
D5	LC0179	Recirculating, Off-Board Tanks, 1/4 in. (6.5 mm) - 10 ft (3.0 m)
D6	LC0180	Recirculating, Off-Board Tanks, 1/4 in. (6.5 mm) - 15 ft (4.6 m)
D7	LC0181	Recirculating, Off-Board Tanks, 3/8 in. (9.5 mm) - 2.5 ft (0.6 m)
D8	LC0182	Recirculating, Off-Board Tanks, 3/8 in. (9.5 mm) - 10 ft (3.0 m)
D9	LC0183	Recirculating, Off-Board Tanks, 3/8 in. (9.5 mm) - 15 ft (4.6 m)
DA	LC0184	Recirculating, Off-Board Tanks, 1/2 in. (13 mm) - 2.5 ft (0.6 m)
DB	LC0185	Recirculating, Off-Board Tanks, 1/2 in. (13 mm) - 10 ft (3.0 m)
DC	LC0186	Recirculating, Off-Board Tanks, 1/2 in. (13 mm) - 15 ft (4.6 m)
DD	LC0187	Recirculating, Off-Board Tanks, 3/4 in. (19 mm) - 10 ft (3.0 m)
DE	LC0188	Recirculating, Off-Board Tanks, 3/4 in. (19 mm) - 15 ft (4.6 m)
E1	LC0190	Recirculating, Heated, On-Board Tanks, 1/4 in. (6.5 mm) - 2.5 ft (0.6 m)

E2	LC0191	Recirculating, Heated, On-Board Tanks, 1/4 in. (6.5 mm) - 10 ft (3.0 m)
E3	LC0192	Recirculating, Heated, On-Board Tanks, 1/4 in. (6.5 mm) - 15 ft (4.6 m)
E4	LC0193	Recirculating, Heated, On-Board Tanks, 3/8 in. (9.5 mm) - 2.5 ft (0.6 m)
E5	LC0194	Recirculating, Heated, On-Board Tanks, 3/8 in. (9.5 mm) - 10 ft (3.0 m)
E6	LC0195	Recirculating, Heated, On-Board Tanks, 3/8 in. (9.5 mm) - 15 ft (4.6 m)
E7	LC0196	Recirculating, Heated, On-Board Tanks, 1/2 in. (13 mm) - 2.5 ft (0.6 m)
E8	LC0197	Recirculating, Heated, On-Board Tanks, 1/2 in. (13 mm) - 10 ft (3.0 m)
E9	LC0198	Recirculating, Heated, On-Board Tanks, 1/2 in. (13 mm) - 15 ft (4.6 m)
EA	LC0199	Recirculating, Heated, On-Board Tanks, 3/4 in. (19 mm) - 10 ft (3.0 m)
EB	LC0200	Recirculating, Heated, On-Board Tanks, 3/4 in. (19 mm) - 15 ft (4.6 m)
F1	LC0201	Recirculating, Heated, Off-Board Tanks, 1/4 in. (6.5 mm) - 2.5 ft (0.6 m)
F2	LC0202	Recirculating, Heated, Off-Board Tanks, 1/4 in. (6.5 mm) - 10 ft (3.0 m)
F3	LC0203	Recirculating, Heated, Off-Board Tanks, 1/4 in. (6.5 mm) - 15 ft (4.6 m)
F4	LC0204	Recirculating, Heated, Off-Board Tanks, 3/8 in. (9.5 mm) - 2.5 ft (0.6 m)
F5	LC0205	Recirculating, Heated, Off-Board Tanks, 3/8 in. (9.5 mm) - 10 ft (3.0 m)
F6	LC0206	Recirculating, Heated, Off-Board Tanks, 3/8 in. (9.5 mm) - 15 ft (4.6 m)
F7	LC0207	Recirculating, Heated, Off-Board Tanks, 1/2 in. (13 mm) - 2.5 ft (0.6 m)
F8	LC0208	Recirculating, Heated, Off-Board Tanks, 1/2 in. (13 mm) - 10 ft (3.0 m)
F9	LC0209	Recirculating, Heated, Off-Board Tanks, 1/2 in. (13 mm) - 15 ft (4.6 m)
FA	LC0210	Recirculating, Heated, Off-Board Tanks, 3/4 in. (19 mm) - 10 ft (3.0 m)
FB	LC0211	Recirculating, Heated, Off-Board Tanks, 3/4 in. (19 mm) - 15 ft (4.6 m)
GA	LC0400	High Pressure, 3/8 in. (9.5 mm) - 2.5 ft (0.6 m)
GB	LC0401	High Pressure, 3/8 in. (9.5 mm) - 10 ft (3.0 m)
GC	LC0402	High Pressure, 3/8 in. (9.5 mm) - 15 ft (4.6 m)
GD	LC0403	High Pressure, 1/2 in. (13 mm) - 2.5 ft (0.6 m)
GE	LC0404	High Pressure, 1/2 in. (13 mm) - 10 ft (3.0 m)
GF	LC0405	High Pressure, 1/2 in. (13 mm) - 15 ft (4.6 m)

GH	LC0406	High Pressure, 3/4 in. (19 mm) - 10 ft (3.0 m)
GJ	LC0407	High Pressure, 3/4 in. (19 mm) - 15 ft (4.6 m)
GK	LC0432	High Pressure, Recirculating, On-Board Tanks, 3/8 in. (9.5 mm) - 2.5 ft (0.6 m)
GL	LC0433	High Pressure, Recirculating, On-Board Tanks, 3/8 in. (9.5 mm) - 10 ft (3.0 m)
GM	LC0434	High Pressure, Recirculating, On-Board Tanks, 3/8 in. (9.5 mm) - 15 ft (4.6 m)
GQ	LC0435	High Pressure, Recirculating, On-Board Tanks, 1/2 in. (13 mm) - 2.5 ft (0.6 m)
GR	LC0436	High Pressure, Recirculating, On-Board Tanks, 1/2 in. (13 mm) - 10 ft (3.0 m)
GS	LC0437	High Pressure, Recirculating, On-Board Tanks, 1/2 in. (13 mm) - 15 ft (4.6 m)
GT	LC0438	High Pressure, Recirculating, On-Board Tanks, 3/4 in. (19 mm) - 10 ft (3.0 m)
GU	LC0439	High Pressure, Recirculating, On-Board Tanks, 3/4 in. (19 mm) - 15 ft (4.6 m)
GW	LC0440	High Pressure, Recirculating, On-Board Tanks, 3/8 in. (9.5 mm) - 2.5 ft (0.6 m)
GX	LC0441	High Pressure, Recirculating, On-Board Tanks, 3/8 in. (9.5 mm) - 10 ft (3.0 m)
GY	LC0442	High Pressure, Recirculating, On-Board Tanks, 3/8 in. (9.5 mm) - 15 ft (4.6 m)
G1	LC0443	High Pressure, Recirculating, On-Board Tanks, 1/2 in. (13 mm) - 2.5 ft (0.6 m)
G2	LC0444	High Pressure, Recirculating, On-Board Tanks, 1/2 in. (13 mm) - 10 ft (3.0 m)
G3	LC0445	High Pressure, Recirculating, On-Board Tanks, 1/2 in. (13 mm) - 15 ft (4.6 m)
G4	LC0446	High Pressure, Recirculating, On-Board Tanks, 3/4 in. (19 mm) - 10 ft (3.0 m)
G5	LC0447	High Pressure, Recirculating, On-Board Tanks, 3/4 in. (19 mm) - 15 ft (4.6 m)
HA	LC0472	High Pressure, Heated, 3/8 in. (9.5 mm) - 2.5 ft (0.6 m)
HB	LC0473	High Pressure, Heated, 3/8 in. (9.5 mm) - 10 ft (3.0 m)

HC	LC0474	High Pressure, Heated, 3/8 in. (9.5 mm) - 15 ft (4.6 m)
HF	LC0475	High Pressure, Heated, 1/2 in. (13 mm) - 2.5 ft (0.6 m)
HG	LC0476	High Pressure, Heated, 1/2 in. (13 mm) - 10 ft (3.0 m)
HJ	LC0477	High Pressure, Heated, 1/2 in. (13 mm) - 15 ft (4.6 m)
HL	LC0478	High Pressure, Heated, 3/4 in. (19 mm) - 10 ft (3.0 m)
HM	LC0479	High Pressure, Heated, 3/4 in. (19 mm) - 15 ft (4.6 m)
HQ	LC0480	High Pressure, Heated, 3/8 in. (9.5 mm) - 2.5 ft (0.6 m)
HR	LC0481	High Pressure, Heated, 3/8 in. (9.5 mm) - 10 ft (3.0 m)
HS	LC0482	High Pressure, Heated, 3/8 in. (9.5 mm) - 15 ft (4.6 m)
HT	LC0483	High Pressure, Heated, 1/2 in. (13 mm) - 2.5 ft (0.6 m)
HU	LC0484	High Pressure, Heated, 1/2 in. (13 mm) - 10 ft (3.0 m)
HX	LC0485	High Pressure, Heated, 1/2 in. (13 mm) - 15 ft (4.6 m)
HY	LC0486	High Pressure, Heated, 3/4 in. (19 mm) - 10 ft (3.0 m)
H2	LC0487	High Pressure, Heated, 3/4 in. (19 mm) - 15 ft (4.6 m)
NN	---	Not required
Code K Part Dispense Valve		
N	N/A	None
2	255179	MD2, Valve Only with 1:1 Nose
3	255181	MD2, Valve Only with 10:1 Nose
4	LC0120	MD2, Handheld with 1:1 Nose
5	LC0122	MD2, Handheld with 10:1 Nose
6	LC0121	MD2, Lever with 1:1 Nose
7	LC0123	MD2, Lever with 10:1 Nose
Code L Part Mixer Type		
N	N/A	None
1	LC0063	3/16 in. (4.8 mm) x 32
2	LC0057	1/4 in. (6.4 mm) x 24
3	LC0058	3/8 in. (9.5 mm) x 24
4	LC0059	3/8 in. (9.5 mm) x 36
5	LC0060	3/8 in. (9.5 mm) Combo
6	LC0062	1/4 in. (6.4 mm) x 24 Luer Lock
7	LC0061	3/16 in. (4.8 mm) x 32 Luer Lock
8	LC0295	1/2 in. (12.7 mm) x 24
9	LC0296	1/2 in. (12.7 mm) x 36

Code M		Part	Applicator Mounting
N	LC0294		None, Customer Mount Controls and Applicator
1	LC0292		Mast Mount, Controls & MD2 Applicator Machine Mounted
2	LC0293		Mast Mount, Controls Only
3	256439		Tank Stand Mount, Controls & MD2 Applicator Machine Mounted
4	256438		Tank Stand Mount, Controls Only
Code N		Part	Power Cord Option
1	121055		120VAC North American Cord Set
2	121054		10A, 250V US Cord Set
3	121056		10A, 250V Continental europe
4	121057		10A, 250V U.K./Ireland
5	121058		10A, 250V Israel
6	124864		10A, 250V Australia
7	124861		10A, 250V Italy
8	124863		10A, 250V Switzerland
9	124862		10A, 250V Denmark
A	121060		10A, 250V India
B	N/A		Heat Controller Option
Code O		Part	Flow Monitoring
N	LC0041		None
1	257433		Pressure Transducer
2	LC0302		Two 0.5 gpm Flow Meters, No Pressure Transducers
3	LC0305		Two 1.0 gpm Flow Meters, No Pressure Transducers
4	LC0303		One 1.0 gpm Flow Meter, One 0.5 gpm Flow Meter, No Pressure Transducers
5	LC0307		Two 2.0 gpm Flow Meters, No Pressure Transducers
6	LC0306		One 2.0 gpm Flow Meter, One 1.0 gpm Flow Meter, No Pressure Transducers
7	LC0304		One 2.0 gpm Flow Meter, One 0.5 gpm Flow Meter, No Pressure Transducers
A	LC0312		Two 0.5 gpm Flow Meters, With Pressure Transducers
B	LC0315		Two 1.0 gpm Flow Meters, With Pressure Transducers
C	LC0313		One 1.0 gpm Flow Meter, One 0.5 gpm Flow Meter, With Pressure Transducers
D	LC0317		Two 2.0 gpm Flow Meters, With Pressure Transducers
E	LC0316		One 2.0 gpm Flow Meter, One 1.0 gpm Flow Meter, With Pressure Transducers

F	LC0314	One 2.0 gpm Flow Meter, One 0.5 gpm Flow Meter, With Pressure Transducers	
Code P		Part	High Volume Side Tank
N	N/A		None
1	256896		No Tanks, 1 1/2 in. npt flange
2	255241		8 L, Twin Polyethylene Tanks and Lids
3	255250		8 L, Twin Polyethylene Tanks and Lids, One 120V Agitator
4	255251		8 L, Twin Polyethylene Tanks and Lids, Two 120V Agitators
5	255281		8 L, Twin Polyethylene Tanks and Lids, with Shut-Off Valves
6	255282		8 L, Twin Polyethylene Tanks and Lids, One 120V Agitator, with Shut-Off Valves
7	255283		8 L, Twin Polyethylene Tanks and Lids, Two 120V Agitators, with Shut-Off Valves
8	LC0235◆		7.5 L, Stainless Steel, High Level Sensors
9	LC0236◆		7.5 L, Stainless Steel, High Level Sensors, with Shut-Off Valve
A	LC0013◆		3 L, Stainless Steel
B	LC0012◆		7.5 L, Stainless Steel
C	255285◆		3 L, Stainless Steel, with Shut-Off Valve
D	LC0156		8 L, Twin Polyethylene Tanks and Lids, One Pneumatic Agitator
E	LC0157		8 L, Twin Polyethylene Tanks and Lids, Two Pneumatic Agitator
F	255284◆		7.5 L, Stainless Steel, with Shut-Off Valve
G	LC0254◆		7.5 L, Stainless Steel, 240V Heat
H	LC0255◆		7.5 L, Stainless Steel, 240V Heat, with Shut-Off Valve
J	LC0054		30 L, Stainless Steel
K	LC0158		8 L, Twin Polyethylene Tanks and Lids, One Pneumatic Agitator, with Shut-Off Valves
L	LC0259		30 L, Stainless Steel, 240V Heat
M	LC0055		60 L, Stainless Steel
P	LC0159		8 L, Twin Polyethylene Tanks and Lids, Two Pneumatic Agitators, with Shut-Off Valves
R	LC0260		60 L, Stainless Steel, 240V Heat

S	LC0126	8 L, Twin Polyethylene Tanks and Lids, One 240V Agitator
T	LC0127	8 L, Twin Polyethylene Tanks and Lids, Two 240V Agitators
U	LC0128	8 L, Twin Polyethylene Tanks and Lids, One 240V Agitator, with Shut-Off Valves
V	LC0238◆	7.5 L, Stainless Steel, High Level Sensors, 240V Heat, with Shut-Off Valve
W	LC0129	8 L, Twin Polyethylene Tanks and Lids, Two 240V Agitators, with Shut-Off Valves
X	25B196	Accumulator, Fluoroelastomer
Y	LC0297	Accumulator, EP
Z	LC0237◆	7.5 L, Stainless Steel, High Level Sensors, 240V Heat
---	◆	When ordering tanks for spare or replacement parts, refer to Parts , page 27.
Code Q	Part	High Volume Side Tank Cover
N	N/A	None
1	LC0018	On-Board Dust Cover
2	LC0019	On-Board Clamp Down
3	LC0020	On-Board Vacuum De-gas
4	LC0021	On-Board Agitate 120VAC 50/60 Hz
5	LC0022	On-Board Agitate 240VAC 50/60 Hz
6	LC0023	On-Board Agitate 120 VAC 50/60 Hz and De-gas
7	LC0024	On-Board Agitate 240 VAC 50/60 Hz and De-gas
8	LC0025	On-Board 120VAC 50/60 Hz, De-gas and Fill-Port
9	LC0026	On-Board 240 VAC 50/60 Hz, De-gas and Fill-Port
A	LC0142	Off-Board Clamp Down - 30L
B	LC0101	Off-Board Clamp Down - 60L
C	LC0043	Off-Board Vacuum De-gas - 30L
F	LC0102	Off-Board Vacuum De-gas - 60L
G	LC0047	Off-Board Electric Agitator - 30L
H	LC0048	Off-Board Electric Agitator - 60L
K	LC0147	Off-Board Vacuum De-gas, Pneumatic Agitator, Fill Port, Slinger - 60 L
M	LC0051	Off-Board Vacuum De-gas, Electric Agitator, Fill Port, Slinger - 30 L
R	LC0052	Off-Board Vacuum De-gas, Electric Agitator, Fill Port, Slinger - 60 L
S	LC0130	On-Board, Pneumatic Agitate
T	LC0131	On-Board, Pneumatic Agitate, De-gas





U	LC0132	On-Board, Pneumatic Agitate, De-gas, Fill Port
V	LC0142	Off-Board Pneumatic Agitator - 30 L
W	LC0143	Off-Board Pneumatic Agitator - 60 L
Z	LC0146	Off-Board Vacuum De-gas, Pneumatic Agitator, Fill Port, Slinger - 30 L
Code R	Part	Low Volume Side Tank
N	N/A	None
1	256896	No Tanks, 1 1/2 in. npt flange
8	LC0235◆	7.5 L, Stainless Steel, High Level Sensors
9	LC0236◆	7.5 L, Stainless Steel, High Level Sensors, with Shut-Off Valve
A	LC0013◆	3 L, Stainless Steel
B	LC0012◆	7.5 L, Stainless Steel
C	255285◆	3 L, Stainless Steel, with Shut-Off Valve
F	255284◆	7.5 L, Stainless Steel, with Shut-Off Valve
G	LC0254◆	7.5 L, Stainless Steel, 240V Heat
H	LC0255◆	7.5 L, Stainless Steel, 240V Heat, with Shut-Off Valve
J	LC0054	30 L, Stainless Steel
L	LC0259	30 L, Stainless Steel, 240V Heat
M	LC0055	60 L, Stainless Steel
R	LC0260	60 L, Stainless Steel, 240V Heat
V	LC0238◆	7.5 L, Stainless Steel, High Level Sensors, 240V Heat, with Shut-Off Valve
X	25B196	Accumulator, Fluoroelastomer
Z	LC0237◆	7.5 L, Stainless Steel, High Level Sensors, 240V Heat
---	◆	When ordering tanks for spare or replacement parts, refer to Parts , page 27.
Code S	Part	Low Volume Side Tank Covers
N	N/A	None
1	LC0018	On-Board Dust Cover
2	LC0019	On-Board Clamp Down
3	LC0020	On-Board Vacuum De-gas
4	LC0021	On-Board Agitate 120VAC 50/60 Hz
5	LC0022	On-Board Agitate 240VAC 50/60 Hz
6	LC0023	On-Board Agitate 120 VAC 50/60 Hz and De-gas
7	LC0024	On-Board Agitate 240 VAC 50/60 Hz and De-gas
8	LC0025	On-Board 120VAC 50/60 Hz, De-gas and Fill-Port
9	LC0026	On-Board 240 VAC 50/60 Hz, De-gas and Fill-Port
A	LC0142	Off-Board Clamp Down - 30L

B	LC0101	Off-Board Clamp Down - 60L
C	LC0043	Off-Board Vacuum De-gas - 30L
F	LC0102	Off-Board Vacuum De-gas - 60L
G	LC0047	Off-Board Electric Agitator - 30L
H	LC0048	Off-Board Electric Agitator - 60L
K	LC0147	Off-Board Vacuum De-gas, Pneumatic Agitator, Fill Port, Slinger - 60 L
M	LC0051	Off-Board Vacuum De-gas, Electric Agitator, Fill Port, Slinger - 30 L
R	LC0052	Off-Board Vacuum De-gas, Electric Agitator, Fill Port, Slinger - 60 L
S	LC0130	On-Board, Pneumatic Agitate
T	LC0131	On-Board, Pneumatic Agitate, De-gas
U	LC0132	On-Board, Pneumatic Agitate, De-gas, Fill Port
V	LC0142	Off-Board Pneumatic Agitator - 30 L
W	LC0143	Off-Board Pneumatic Agitator - 60 L
Z	LC0146	Off-Board Vacuum De-gas, Pneumatic Agitator, Fill Port, Slinger - 30 L
Code T	Part	Tank Level Sensors
N	N/A	None
2	LC0278	Polyethylene Tanks - Low Level Sensors Only
3	LC0279	Two 7.5 L Stainless Steel Tanks - Low Level Sensors Only
4	LC0282	Two 30 L or 60 L Stainless Steel Tanks - Low Level Sensors Only
5	LC0281	7.5 L Stainless Steel - Low Level Sensors Only, and 30 L or 60 L Stainless Steel - Low Level Sensors Only
6	LC0280	Accumulator Sensors, and 7.5 L Low Level Sensors
7	LC0283	Accumulator Sensors, and 30 L or 60 L Low Level Sensors
9	LC0284	Two 7.5 L Stainless Steel Tanks - High and Low Level Sensors with Refill Logic
A	LC0287	Two 30 L or 60 L Stainless Steel Tanks - High and Low Level Sensors with Refill Logic
B	LC0286	7.5 L Stainless Steel - Low Level Sensors, and 30 L or 60 L Stainless Steel - High and Low Level Sensors with Refill Logic
C	LC0289	7.5 L Stainless Steel - High and Low Level Sensors with Refill Logic, and 30 L or 60 L Stainless Steel - High and Low Level Sensors with Refill Logic
D	LC0285	Accumulator Sensors, and 7.5 L High and Low Level Sensors
E	LC0288	Accumulator Sensors, and 30 L or 60 L High and Low Level Sensors
G	N/A	Two Sets of Accumulator Sensors

Code U	Part	Heat Zone Controller
N	N/A	None
C	LC0250	1 Tank or 1 Hose
D	LC0251	2 Tanks, 1 Tank and 1 Hose, or 2 Hoses
E	LC0252	2 Tanks and 1 Hose, or 1 Tank and 2 Hoses
F	LC0253	2 Tanks and 2 Hoses
Code V	Part	Off-Board Tank Stands
N	N/A	None
2	LC0103	PR70 Tank Stand
3	LC0247	PR70v Tank Stand

Warnings

The following warnings are for the setup, use, grounding, maintenance, and repair of this equipment. The exclamation point symbol alerts you to a general warning and the hazard symbol refers to procedure-specific risk. Refer back to these warnings. Additional, product-specific warnings may be found throughout the body of this manual where applicable.

 WARNING	
	<p>ELECTRIC SHOCK HAZARD</p> <p>Improper grounding, setup, or usage of the system can cause electric shock.</p> <ul style="list-style-type: none"> • Turn off and disconnect power cord before servicing equipment. • Use only grounded electrical outlets. • Use only 3-wire extension cords. • Ensure ground prongs are intact on power and extension cords. • Do not expose to rain. Store indoors.
	<p>SKIN INJECTION HAZARD</p> <p>High-pressure fluid from dispense valve, hose leaks, or ruptured components will pierce skin. This may look like just a cut, but it is a serious injury that can result in amputation. Get immediate surgical treatment.</p> <ul style="list-style-type: none"> • Do not point dispense valve at anyone or at any part of the body. • Do not put your hand over the end of the dispense nozzle. • Do not stop or deflect leaks with your hand, body, glove, or rag. • Follow Pressure Relief Procedure in this manual, when you stop spraying and before cleaning, checking, or servicing equipment.
	<p>TOXIC FLUID OR FUMES HAZARD</p> <p>Toxic fluids or fumes can cause serious injury or death if splashed in the eyes or on skin, inhaled, or swallowed.</p> <ul style="list-style-type: none"> • Read MSDS's to know the specific hazards of the fluids you are using. • Store hazardous fluid in approved containers, and dispose of it according to applicable guidelines. • Always wear impervious gloves when spraying or cleaning equipment.
	<p>PERSONAL PROTECTIVE EQUIPMENT</p> <p>You must wear appropriate protective equipment when operating, servicing, or when in the operating area of the equipment to help protect you from serious injury, including eye injury, inhalation of toxic fumes, burns, and hearing loss. This equipment includes but is not limited to:</p> <ul style="list-style-type: none"> • Protective eyewear • Clothing and respirator as recommended by the fluid and solvent manufacturer • Gloves • Hearing protection

WARNING
**FIRE AND EXPLOSION HAZARD**

Flammable fumes, such as solvent and paint fumes, in work area can ignite or explode. To help prevent fire and explosion:

- Use equipment only in well ventilated area.
- Eliminate all ignition sources; such as pilot lights, cigarettes, portable electric lamps, and plastic drop cloths (potential static arc).
- Keep work area free of debris, including solvent, rags and gasoline.
- Do not plug or unplug power cords or turn lights on or off when flammable fumes are present.
- Ground all equipment in the work area. See **Grounding** instructions.
- If there is static sparking or you feel a shock, **stop operation immediately**. Do not use equipment until you identify and correct the problem.
- Keep a working fire extinguisher in the work area.

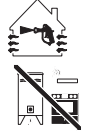
**EQUIPMENT MISUSE HAZARD**

Misuse can cause death or serious injury.

- Do not operate the unit when fatigued or under the influence of drugs or alcohol.
- Do not exceed the maximum working pressure or temperature rating of the lowest rated system component. See **Technical Data** in all equipment manuals.
- Use fluids and solvents that are compatible with equipment wetted parts. See **Technical Data** in all equipment manuals. Read fluid and solvent manufacturer's warnings. For complete information about your material, request MSDS forms from distributor or retailer.
- Check equipment daily. Repair or replace worn or damaged parts immediately with genuine manufacturer's replacement parts only.
- Do not alter or modify equipment.
- Use equipment only for its intended purpose. Call your distributor for information.
- Route hoses and cables away from traffic areas, sharp edges, moving parts, and hot surfaces.
- Do not kink or over bend hoses or use hoses to pull equipment.
- Keep children and animals away from work area.
- Comply with all applicable safety regulations.

**BURN HAZARD**

Equipment surfaces and fluid that's heated can become very hot during operation. To avoid severe burns, do not touch hot fluid or equipment. Wait until equipment/fluid has cooled completely.

Moisture Sensitivity of Isocyanates

Isocyanates (ISO) are catalysts used in two component foam and polyurea coatings. ISO will react with moisture (such as humidity) to form small, hard, abrasive crystals, which become suspended in the fluid. Eventually a film will form on the surface and the ISO will begin to gel, increasing in viscosity. If used, this partially cured ISO will reduce performance and the life of all wetted parts.

NOTE: The amount of film formation and rate of crystallization varies depending on the blend of ISO, the humidity, and the temperature.

To prevent exposing ISO to moisture:

- Always use a sealed container with a desiccant dryer in the vent, or a nitrogen atmosphere. **Never** store ISO in an open container.
- The PR70 has exposed shafts, so extra precautions must be taken when using ISO Materials. Make sure that the shafts are wiped clean and lubricated if sitting unused for any length of time, such as overnight shutdowns. The lubricant creates a barrier between the ISO and the atmosphere. Evaluate your system and follow this procedure more often if necessary.
- Use moisture-proof hoses specifically designed for ISO, such as those supplied with your system.
- Never use reclaimed solvents, which may contain moisture. Always keep solvent containers closed when not in use.
- Never use solvent on one side if it has been contaminated from the other side.
- Always lubricate threaded parts with ISO pump oil or grease when reassembling.

Grounding

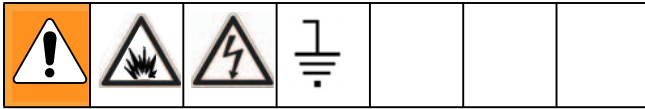



Products that include electric agitators, heated hoses, or heated tanks must be grounded. In the event of an electrical short circuit, grounding reduces the risk of electric shock by providing an escape wire for the electric current. This product is equipped with a cord having a grounding wire with an appropriate grounding plug. The plug must be plugged into an outlet that is properly installed and grounded in accordance with all local codes and ordinances.

Improper installation of the grounding plug is able to result in a risk of electric shock. When repair or replacement of the cord or plug is required, do not connect the grounding wire to either flat blade terminal. The wire with insulation having an outer surface that is green with or without yellow stripes is the grounding wire. Do not modify the plug provided; if it does not fit the outlet, have the proper outlet installed by a qualified electrician. Only connect the product to an outlet having the same configuration as the plug. Do not use an adapter with this product.

Installation

Polyethylene Tank Lid with Agitator

						
<p>The polyethylene tank lid o-ring is installed with Krytox. Contact with Krytox can lead to flu-like symptoms. The MSDS for this material is available upon request.</p>						

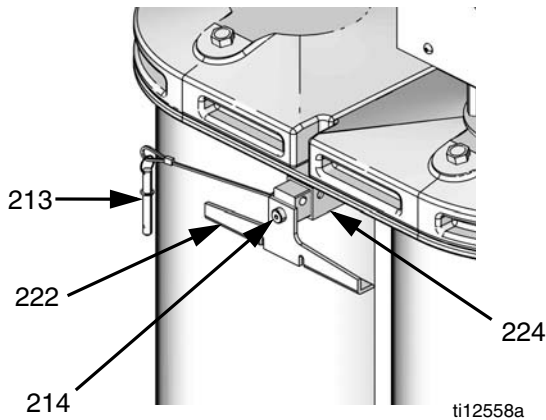

1. Remove tethered quick-release pin (213) from both sides of tank support beam (224).
2. Slide the clamp (222) out of each side of the support beam (224) until it hits the stop.
3. Rotate the clamp (222) 180 degrees about the shoulder screw (214) so it is hanging freely.
4. The tank lid assembly can now be removed or installed as required. Install tank lid assembly onto tank body.
5. Rotate the clamp (222) 180 degrees about the shoulder screw (214) so it is in position to secure the tank lids.
6. With the clamps in position, slide the tethered quick-release pin (213) into place.

7. Attach appropriate hoses and cables.

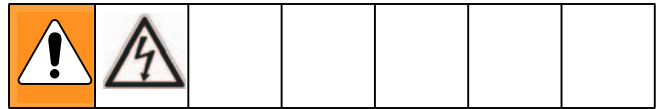

- For electric agitator models, plug the agitator power cable into one of the outlets in the incoming power bracket then turn on the power switch located on the agitator.

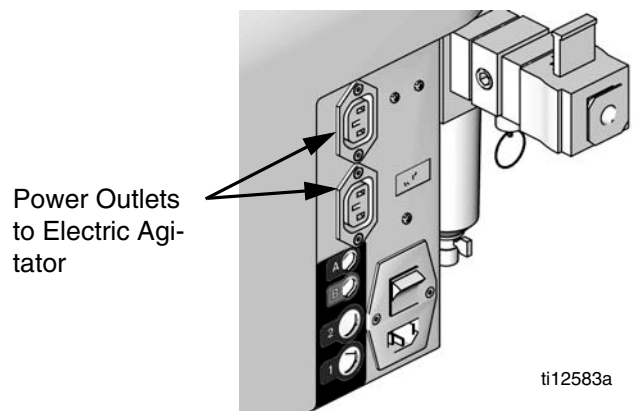

ti12583a

Pneumatic Agitator Motor

--	--	--	--	--	--	--

Always maintain a minimum of one inch clearance between rotating agitator parts and container to prevent sparks caused by contact.

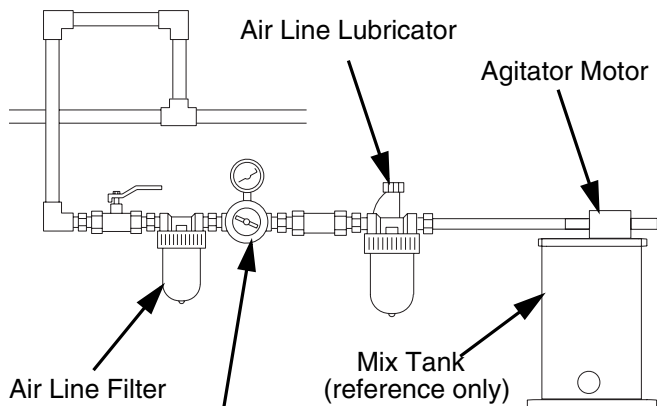

* Air Regulator and Gauge

* Do not use an air regulator and gauge with pneumatic air motor 01/0368-1/11.

FIG. 1: Typical Installation

Ground Pneumatic Agitator Motor

--	--	--	--	--	--	--

The equipment must be grounded. Grounding reduces the risk of static and electric shock by providing an escape wire for the electrical current due to static build up or in the event of a short circuit.

To ground the agitator connect one end of the ground wire (A) to the ground connector (B) on the agitator mounting bracket. Connect the other end of the wire to a true earth ground. For a replacement ground wire and clamp, order Part 237569.

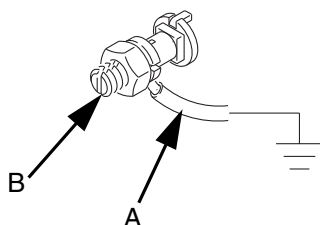

FIG. 2: Ground Agitator Motor

Level Sensors

Polyethylene Tanks

--	--	--	--	--	--	--

1. Install sensor (2001) using two screws (2003). The cable (2002) for the sensor should be pointing towards the center of the machine base.

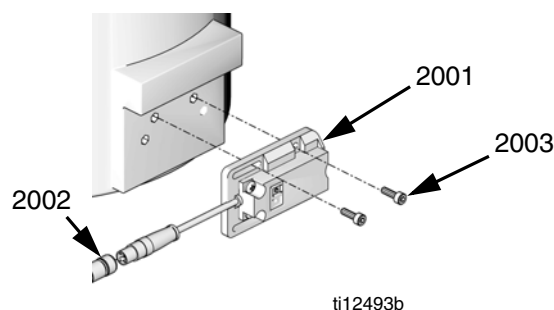

2. Plug the sensor cable (2002) into the connector on the Fluid Control Module as shown in FIG. 3.

Each machine will have either one or two Fluid Control Modules, each labeled as #1 or #2. Fluid Control Module #1 is always used for the low level sensors. Fluid Control Module #2 is always used for the high level sensors. See FIG. 3.

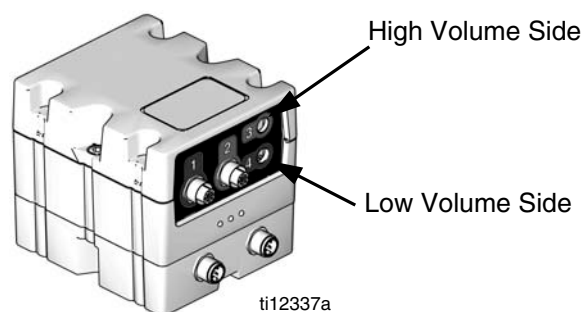
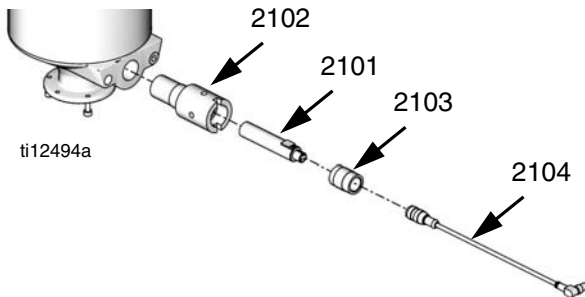



FIG. 3: Fluid Control Module

3. Calibrate the sensors. See **Level Sensor Calibration**, page 20.

Stainless Steel Tanks



1. Empty the tank.
2. Insert the PTFE proximity sensor well (2102) into the tank and turn until flush with the flat face of the tank.
3. Insert the proximity sensor (2101) into the proximity sensor well (2102).
4. Hand tighten the well cap (2103) into the proximity sensor well.
5. Plug the sensor connector (2104) into the connector on the Fluid Control Module as shown in FIG. 3.

 Each machine will have either one or two Fluid Control Modules, each labeled as #1 or #2. Fluid Control Module #1 is always used for the low level sensors. Fluid Control Module #2 is always used for the high level sensors. See FIG. 3.

6. Calibrate the sensor. See **Level Sensor Calibration**, page 20.

Accumulators

 The accumulator level sensors (144) can be installed on any side of the main cylinder (123). However, the sensor must be the specified distance from the pump flange.

CAUTION

To prevent machine damage, if the material being cycled through the accumulator is moisture sensitive, a dryer must be installed in the air supply line before the accumulator.

1. Place the main sensor body (144a) against the side of the main cylinder (123) wall.

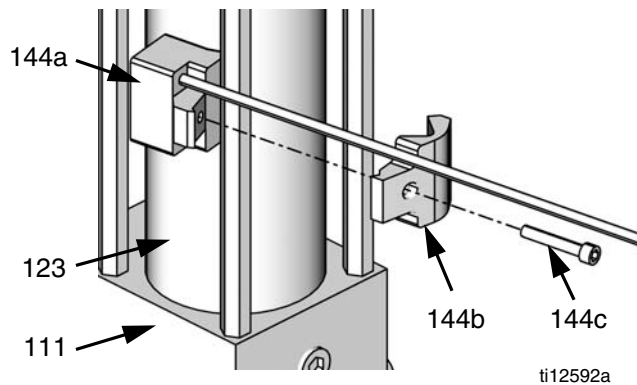



FIG. 4

2. Line up the bolt holes of the clamp (144b) and the main sensor body (144a). Lightly clamp the two together around the nearest tie rod by finger tightening the socket head cap screw (144c) provided.
3. **For accumulator low level sensors**, once the screw (144c) is finger-tight, slide the sensor (144) so it is located 1/2 in. (13 mm) above the bottom pump flange (111).
For accumulator high level sensors, once the screw (144c) is finger-tight, slide the sensor (144) so it is located 1-1/2 in. (38 mm) below the top pump flange (111).
4. Plug the sensor connector into the connector on the Fluid Control Module as shown in FIG. 3.

 Each machine will have either one or two Fluid Control Modules, each labeled as #1 or #2. Fluid Control Module #1 is always used for the low level sensors. Fluid Control Module #2 is always used for the high level sensors. See FIG. 3.

Auto-Refill Installation

The Auto-Refill assembly is shipped uninstalled. The Auto-Refill assembly can be installed in multiple places on the tanks. See FIG. 5.

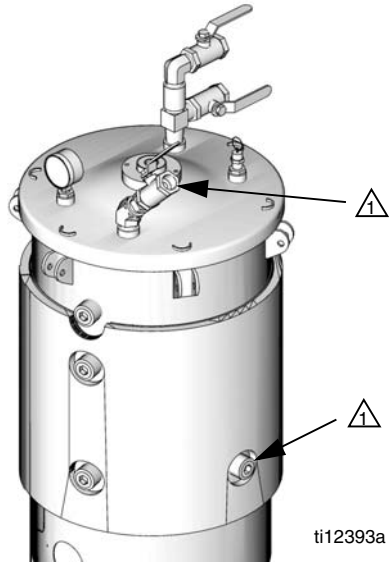

⚠ Possible locations for Auto-Refill installation.



FIG. 5: Auto-Refill Installation Locations

Pressure Transducer and Flow Meter Installation

See manual 312760.

Startup



1. Locate power switch at rear of machine and turn power on. The display module will automatically turn on and begin to load.
2. Slide the system air pressure relief switch up. It is the yellow tab located at the rear, left of the machine. The hole in the tab should not be showing.
3. **For systems with an Advanced Display Module:** if the machine is in Disabled Mode, press the Select Operating Mode button () repeatedly to exit Disabled mode and to select a new operating mode. Press the Enter button () to accept the new operating mode.

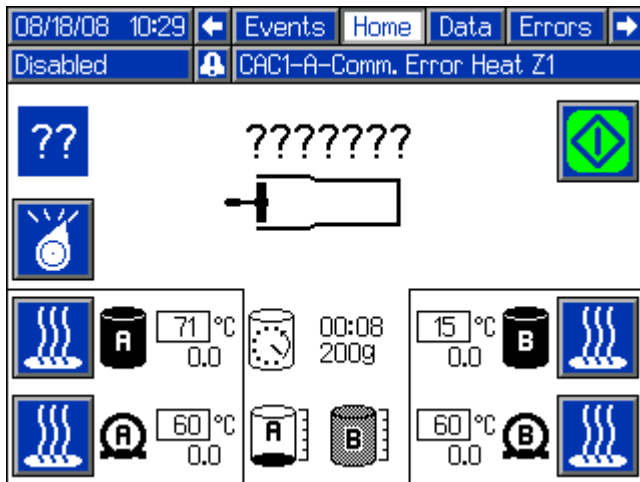



FIG. 6: Advanced Display Module - Disabled Mode

Pressure Relief Procedure

Models with Advanced Display Module





1. Place a waste container below the dispense valve.
2. Navigate to the Manual screen.
3. Press the Open Dispense Valve button on the Manual screen to relieve chemical pressure.
4. Press the Machine Disable Mode button ().
5. Press the system air pressure relief switch down to stop air supply and to vent air pressure in the machine. It is the yellow tab at the left, rear of the machine. The hole in the tab should be visible.
6. If necessary, run a lock through the hole to lock the tab in place. This prevents the system air pressure from being inadvertently enabled.

Models with Standard Display Module



With the machine in an idle state:

1. If the machine pistons are not fully retracted, retract the pistons by pressing  in the M1 screen. See manual 3A0429 for more information.
2. Manually open the dispense valve by pressing the third M1 soft key until the  ICON is shown in the Current DV field. See manual 3A0429 for more information.
3. Press the system air pressure relief switch down to stop air supply and to vent air pressure in the machine. It is the yellow tab at the left, rear of the machine. The hole in the tab should be visible.
4. If necessary, run a lock through the hole to lock the tab in place. This prevents the system air pressure from being inadvertently enabled.

Setup

Level Sensor Calibration

Polyethylene Tanks

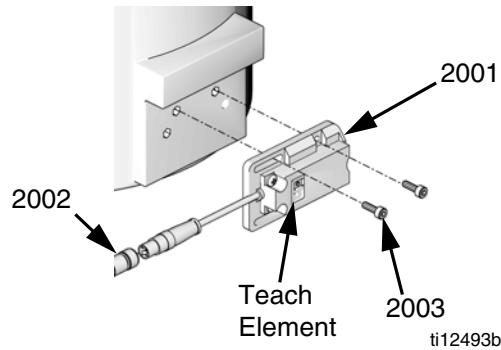

1. Empty tanks by executing multiple shots.
2. Relieve pressure. See **Pressure Relief Procedure**, page 19.
3. With the level sensor installed, locate the “[OUT OFF]” button. Activate teach mode by holding the button down for at least two seconds but no more than six seconds.
4. The LED will flash once and then go out. This signals that the sensor is now in standard operating mode.



5. Using appropriate protective wear, check the sensor for proper operation by reaching inside the tank and placing hand in the area of the sensor. If the LED lights up with your hand next to the sensor, it is functioning properly.

Stainless Steel Tanks

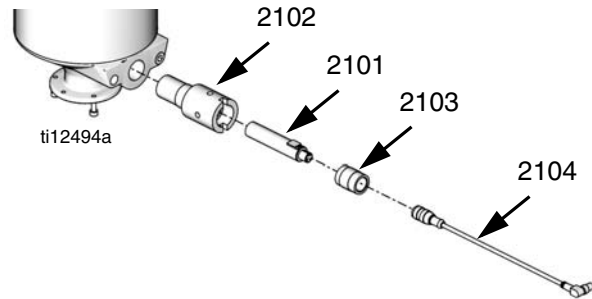
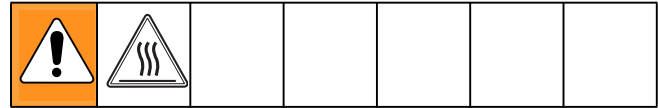



1. Locate the calibration button on the sensor (2101) closest to the electrical connector through one of the four holes of the sensor well (2102).
2. If the calibration button cannot be seen through one of the four holes in the sensor well, rotate the sensor.
 - a. Loosen the sensor well cap (2103).
 - b. Rotate sensor until the calibration button can be seen through one of the four holes in the sensor well.
 - c. Tighten sensor well cap (2103).
 - d. Press and hold the button down with the ball end of an allen wrench for two seconds. The light will flash slowly and then go out.
3. Test for proper sensor function.
 - a. Loosen the sensor well cap (2103).
 - b. Back the sensor out of the well. The sensor should sense the tank wall.

Accumulators

The accumulator low level sensors cannot be calibrated. To ensure proper accumulator sensor operation ensure the sensor is located in the correct location as described in the **Level Sensors** installation section, page 15.

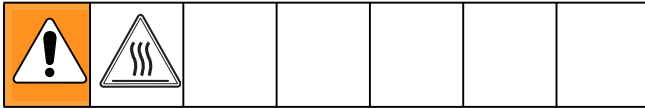
Vacuum De-gas



 This procedure is for assemblies with Vacuum Tree Manifold and No Agitator or Auto-Refill. See FIG. 7.

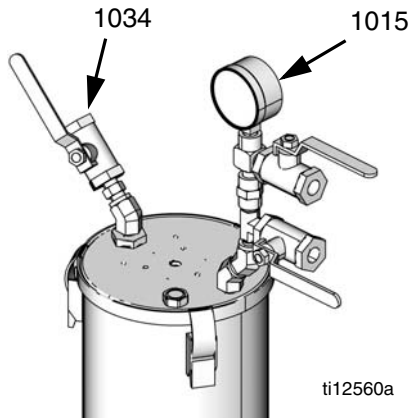





FIG. 7











1. **Models with ADM:** To prevent machine movement, press the Machine Disable Mode key ().
- Models with SDM:** To prevent machine movement, press the Red button .
2. Close the shut-off ball valves at the base of the tanks.
3. If the tank lid has a fill port, turn off any systems that might refill the tank during the vacuum de-gas procedure.
4. Close the fill port ball valve (1034).
5. If the tank lid requires a desiccant dryer or nitrogen pump installed, install one into the top ball valve of the vacuum tree manifold (1015).
6. Close the top ball valve of the vacuum tree manifold (1015).
7. Attach vacuum pump to the bottom ball valve of the vacuum tree manifold (1015) then open the ball valve.
8. Turn on the vacuum pump.
9. Continue to de-gas for sufficient time to de-gas the material.
10. Close bottom ball valve of the vacuum tree manifold (1015).
11. Turn off the vacuum pump.
12. Open the top ball valve of the vacuum tree manifold (1015).
13. Open the shutoff valves at the base of the tanks.

CAUTION

Operating the tank after the vacuum de-gas procedure without the top ball valve open will result in pump cavitation, off-ratio conditions, and possible collapse of the tank.

Vacuum De-gas and Vacuum Auto-Fill

 This procedure is for assemblies with a Vacuum Tree Manifold, Agitator, and Auto-Refill. See FIG. 7 on page 21 for part references.

1. Press the Select Operating Mode button () repeatedly to select Shot, Sequence, or Operator (Manual) mode.
2. Close the shut-off ball valves at the base of the tanks.
3. If the tank lid requires a desiccant dryer or nitrogen pump installed, install one into the top ball valve of the vacuum tree manifold (1015).
4. Close the top ball valve of the vacuum tree manifold (1015).
5. Attach vacuum pump to the bottom ball valve of the vacuum tree manifold (1015) then open the ball valve.
6. Turn on the vacuum pump.
7. Turn on agitator.
8. Select Manual Auto-Refill mode. See operation manual referenced at the beginning of this manual for more information.
9. Press the Initiate Auto-Refill button () . The Active Shot/Sequence button () and Select Operating Mode button () will each change to the Auto-Refill Tank Select button ( or ) if a valid Auto-Refill mode is enabled for both tanks.
10. Press the appropriate Auto-Refill Tank Select button or buttons ( and/or ) to select the tanks to refill.
11. Press the Initiate Auto-Refill button () or the Enter button () to confirm.

12. If necessary, press the Abort/Cancel button () to cancel auto-refill.

 If an auto-refill is aborted or times out, the software will not initiate a new auto-refill until a manually initiated auto-refill has completed. To complete a manually initiated auto-refill after an aborted or timed out auto-refill, restart at step 2.

CAUTION

If an auto-refill is stopped and not restarted as described in the previous note, the pumps may be run dry and chemical crossover at the valve may occur.

13. Continue to de-gas for sufficient time to de-gas the material.
14. Close bottom ball valve of the vacuum tree manifold (1015).
15. Turn off the vacuum pump.
16. Open the top ball valve of the vacuum tree manifold (1015).

CAUTION

Operating the tank after the vacuum de-gas procedure without the top ball valve open will result in pump cavitation, off-ratio conditions, and possible collapse of the tank.

17. Open the shutoff valves at the base of the tanks.

Accumulator Filling

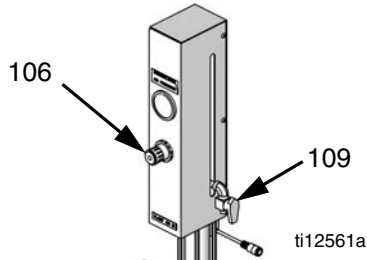
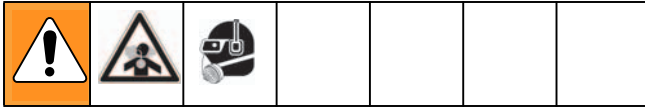

1. Relieve accumulator air pressure to zero using accumulator air pressure regulator (106).
2. Install material feed line to accumulator material inlet (143a) on refill valve (143).

CAUTION

The refill valve has an open port on one side and a closed port on the other. Do not remove the plug opposite the material inlet (143a). The valve will not function properly if the plugged side of the valve is changed.

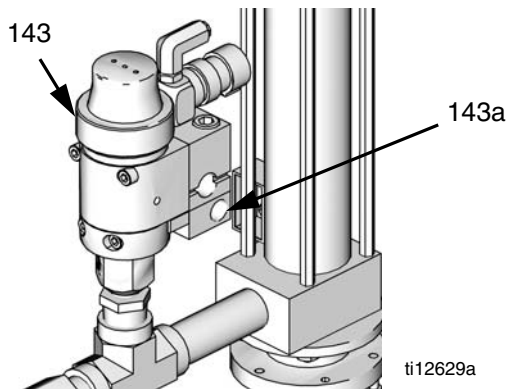

3. Place a waste container below the ball valve (109).
4. Open the ball valve (109).
5. Slowly increase air pressure until the accumulator begins filling slowly.
6. Close the ball valve (109) when material begins to spill into the waste container.

 The vent tube is now full. The accumulator will finish filling and it will stop when the fluid level reaches the high level sensor.

7. Use accumulator air pressure regulator (106) to adjust to desired accumulator air pressure.

 Accumulator air pressure should be set to the lowest possible setting to adequately run the accumulator.

8. See the PR70 and PR70v Operation manual referenced at the beginning of this manual to adjust display module run settings for the accumulator.

Shutdown



If the machine is to remain idle for an extended period of time, perform the following steps.

1. Place a waste container below the dispense valve.
2. If installed, remove static mixer from the end of the dispense valve.
3. Place a container below the dispense valve and activate a small shot to flush mixed material out of the valve.
4. Relieve pressure. See **Pressure Relief Procedure** on page 19.
5. With a clean rag and cotton swabs, clean the end of the dispense valve.
6. Install nightcap on the dispense valve.

Repair



Tank Removal

1. **On models without ball valves**, empty tanks by executing multiple shots.
On models with ball valves, close the ball valves.
2. Relieve pressure. See **Pressure Relief Procedure**, page 19.
3. **For polyethylene tank models**, remove the two screws (211) that attach the tank T-beam support to the pump sub-assembly.

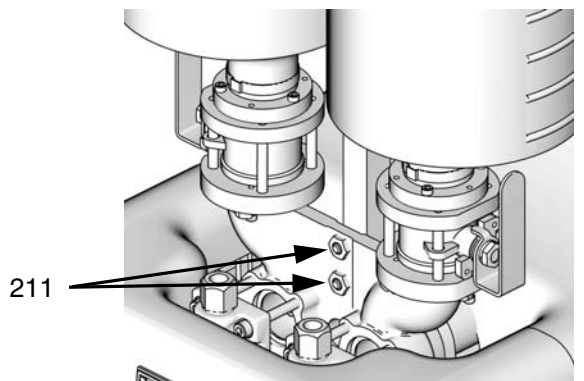

ti12566a

4. **On models without ball valves**, loosen but do not remove the six socket head cap screws (204) that hold the tank to the pump housing.
On models with ball valves, remove the six socket head cap screws (204) that hold the ball valve to the pump housing. The tanks can now be pulled off of the pump housing.

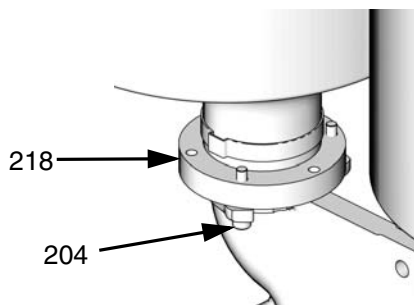

ti12567a

5. **On models without ball valves**, remove the tanks.

- **For polyethylene tank models**, rotate the lock ring (218) for each tank counter clockwise and lift the tanks off of the base.
- **For stainless steel tank models**, rotate the tank counter clockwise and lift the tank off of the base.

Ball Valve Removal from Tank

CAUTION

Disassembly of the ball valve is not recommended. Ensure the ball valve does not accidentally disassemble when detaching the ball valve from the tank.

Polyethylene Tanks

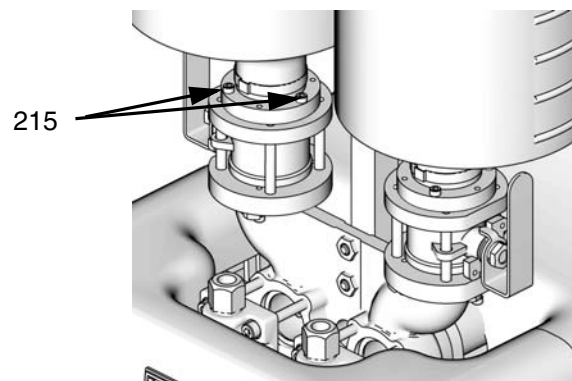

ti12566a

1. Remove polyethylene tank assembly from the base.
2. Remove the six M5 screws (215) holding the two ball valves to the polyethylene tank assembly.

Stainless Steel Tanks

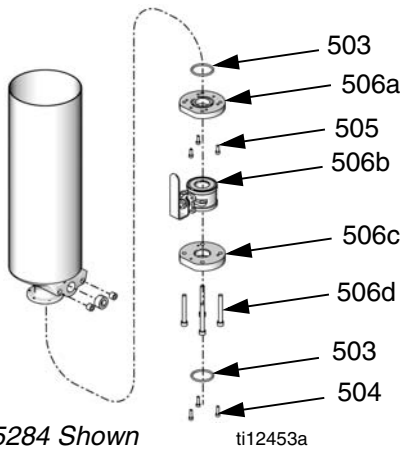

Assembly 255284 Shown

1. Remove the stainless steel tanks from the base.
2. Remove four long screws (506d) holding the ball valve assembly together.
3. Remove three screws (505) holding the tank to the top plate of the ball valve assembly.

Ball Valve Repair

CAUTION

Disassembly of the ball valve is not recommended.

1. Remove ball valve from tank.

 When the ball valve is removed from the tank, it is disassembled.

2. Check o-rings and replace as necessary.

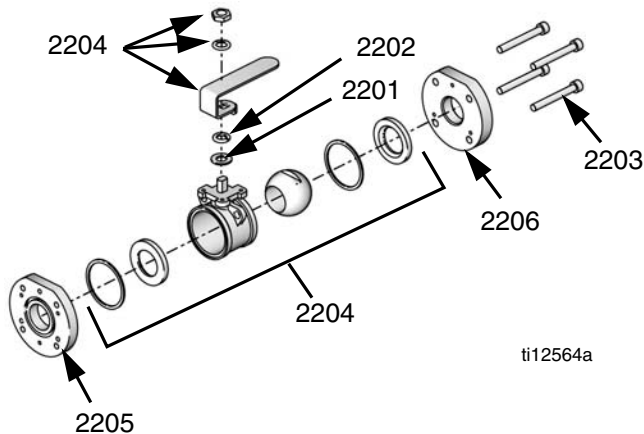

3. Reassemble and install the four screws that hold the ball valve assembly together. Follow ball valve removal from tank procedure in reverse order.

NOTE: If adding or replacing a ball valve, use ball valve kit 26A300. See **Kits** on page 68.

Agitator Fuse Replacement

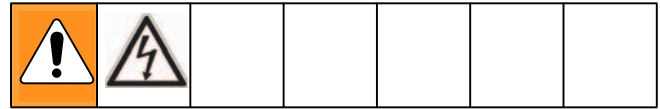
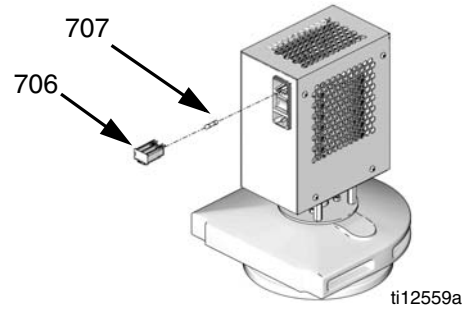

1. Slide open the fuse drawer (706).
2. Remove old fuse (707) and replace with new fuse.

Accumulator, 25B196 continued

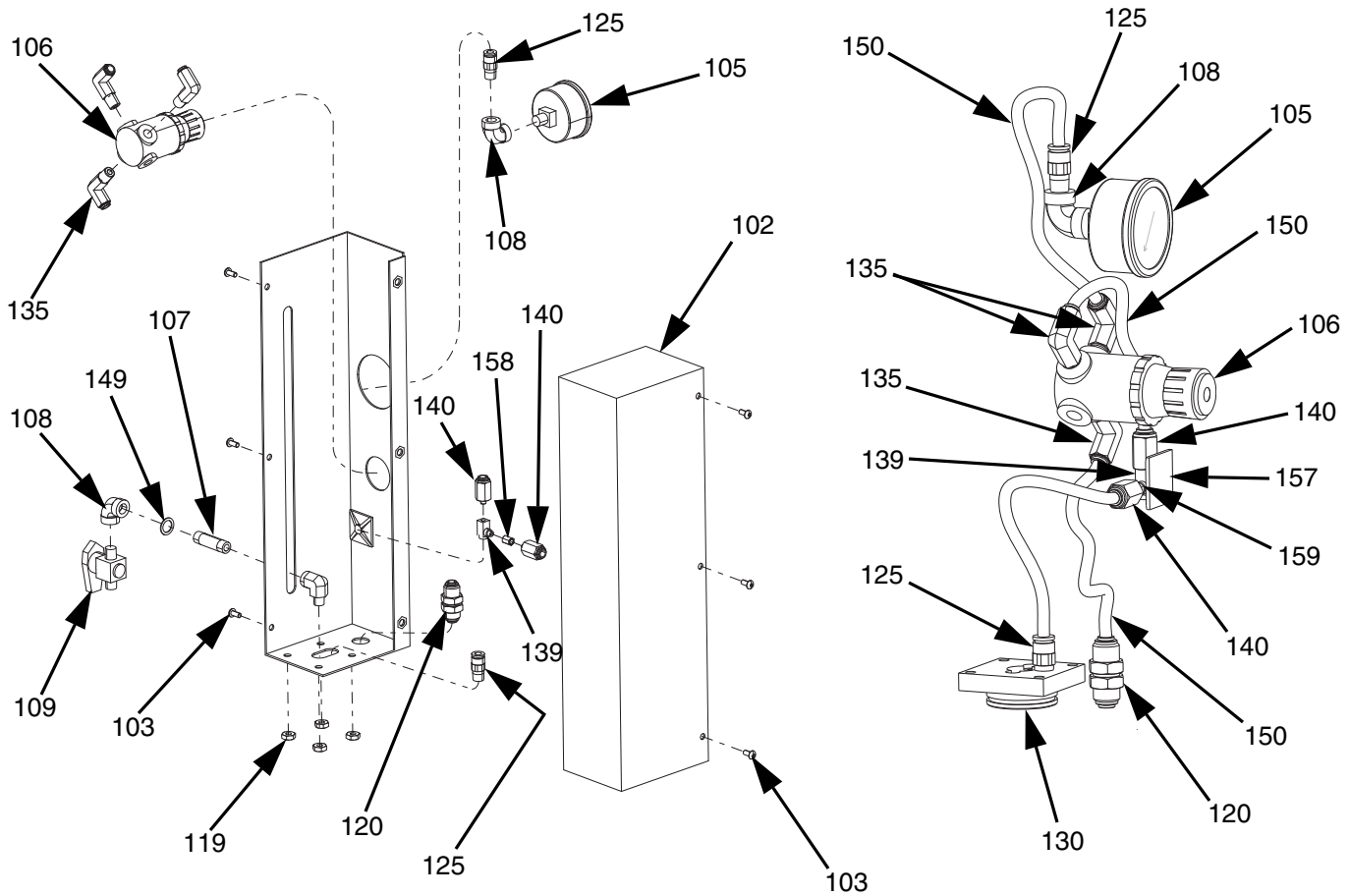

⚠ Apply thread sealant tape to male npt threads prior to installation.

Ref	Part	Description	Qty	Ref	Part	Description	Qty
101	15T679	COVER, front, accumulator, mild steel, PR70	1	109	94/0809/96	VALVE, ball, 2w, 1/8 npt, male, lp, brass	1
102	01/1449/99	COVER, back, accumulator, mild steel	1	110*	15T686	LABEL, accumulator, plant air in	1
103	96/0282/98	FASTENER, screw, button head cap screw, 8-32 x 0.38, stainless steel	6	111	01/1454/98	FLANGE, pump, accumulator, 1.5, stainless steel	1
104*	84/1460-1/11	LABEL, accumulator, air pressure	1	112	121307	FITTING, nipple, 1/2 npt x 3.00, male / male, 304	1
105	82/0053/11	GAUGE, 0-30psi, 2 in., 1/8 npt, back	1	113	94/0616/98A	FITTING, tee, 1/2 npt, female, 3000 psi, 316 ss	1
106	16C406	REGULATOR, air, 1/8 npt, 3-30 psig, 10 scfm	1	114	94/0360-2/98	VALVE, check, 1/2 npt, male, fluoroelastomer, stainless steel, adj	1
107	94/0070/96	FITTING, nipple, 1/8 npt x 1.50, brass	1	115	94/0348/11	CAP, valve, check, 1/2	1
108	94/0642/96	FITTING, elbow, 1/8 npt, female, 90deg, brass	2	116	95/0223/00	O-RING, fluoroelastomer, bbc	2
				117	120904	SCREW, socket head cap, M5 x 0.8 x 18 mm	3

Ref	Part	Description	Qty	Ref	Part	Description	Qty
118	15M849	ADAPTER, accumulator	1	149	23526-01	WASHER, nylon	1
119	96/0304-4/98	NUT, hex, lock, 10-24, stainless steel	8	150	61/0020-A/90	TUBE	2.5
120	94/3201/96	FITTING, union, bulkhead, 1/4 tube	1	151✳†	19A698	WASHER, backup, accumulator	1
121	94/0371/98	PLUG, socket head, 1/2npt, stainless steel	1	152✳†	130871	MAGNET, accumulator, PR70	1
122	01/1453/99	ROD, tie, accumulator, 1.5	4	153†	19A697	INSERT, thread, piston, accumulator	1
123	01/1455/98	CYLINDER, accumulator, 1.5, stainless steel	1	154†	130870	O-RING, fluoroelastomer	2
124†	01/1451/98	TUBE, vent, accumulator, 1.5, stainless steel	1	155✳†	120775	PACKING, o-ring	1
125	94/0702/96	FITTING, 1/4tube x 1/8 npt, male, brass	2	157	84/0805/89	CABLE, tie mount	1
127†	95/0913/00	O-RING, fluoroelastomer, jbh	2	158	132082	COUPLING, hex, female, 10-32, brass	1
128†	95/0605/01	SEAL, u-cup, 1/2 ID x 3/4 OD, NIT	1	159	61/0020-A/90	TUBE	2.5
129†	19A695	PISTON, accumulator, PR70	1	▲ Replacement safety labels, tags, and cards are available at no cost.			
130†	19A696	CAP, end, accumulator	1				
131†	19A699	PISTON, backup, accumulator	1	✳ Not shown.			
132✳†	130872	FASTENER, fhs	3				
133†	130873	FASTENER, fbhs, 6-32 x 25, stainless steel	2	† Parts included in Kit 25B195. See Upgrade Kit, 25B195 on page 69.			
134	94/0527/96	FITTING, elbow, str, 1/8 npt, 90 deg, brass	1				
135	94/0705-1/96	FITTING, elbow, swivel, 1/4 tube x 1/8 npt	3				
136†	19A745	BEARING, rulon, accumulator, PR70	1				
137✳	94/0463/96	FITTING, bushing, 1/8 npt x 10-32, brass	1				
138✳	82/0171/99	FITTING, elbow, street, 10-32, adjustable, chr	1				
139	82/0241/11	VALVE, qck exh, 10-32, mini	1				
140	94/0102/96	CONNECTOR, 1/4tubex10-32, brass	1				
141	94/0301-1/98	FITTING, elbow, str, 90, 1/2 npt, stainless steel	1				
142	94/0568/98	BUSHING, 1/2x1/4npt, male/female, stainless steel, 6K, 316	1				
143	256179	VALVE, assy, on-board tank refill	1				
144	LC0310	HARNESS, reed sw, QC, assy	2				
145✳	121684	CABLE, M12 x M8, 4P, female/male, straight/right angle, 2 m	2				
146✳	121686	CABLE, M8 x M8, 4P, female/male, straight/right angle, 2 m	1				
147✳	94/1063/11	FITTING, tee, union, 1/4 tube	1				
148▲✳	84/0130-27/11	LABEL, hand crush	1				

8 Liter Polyethylene Tanks

CAUTION
<p>The electric agitators used with on-board tanks will fail prematurely when material viscosity exceeds 24,000 cps. Use pneumatic agitators if material viscosity exceeds 24,000 cps.</p>

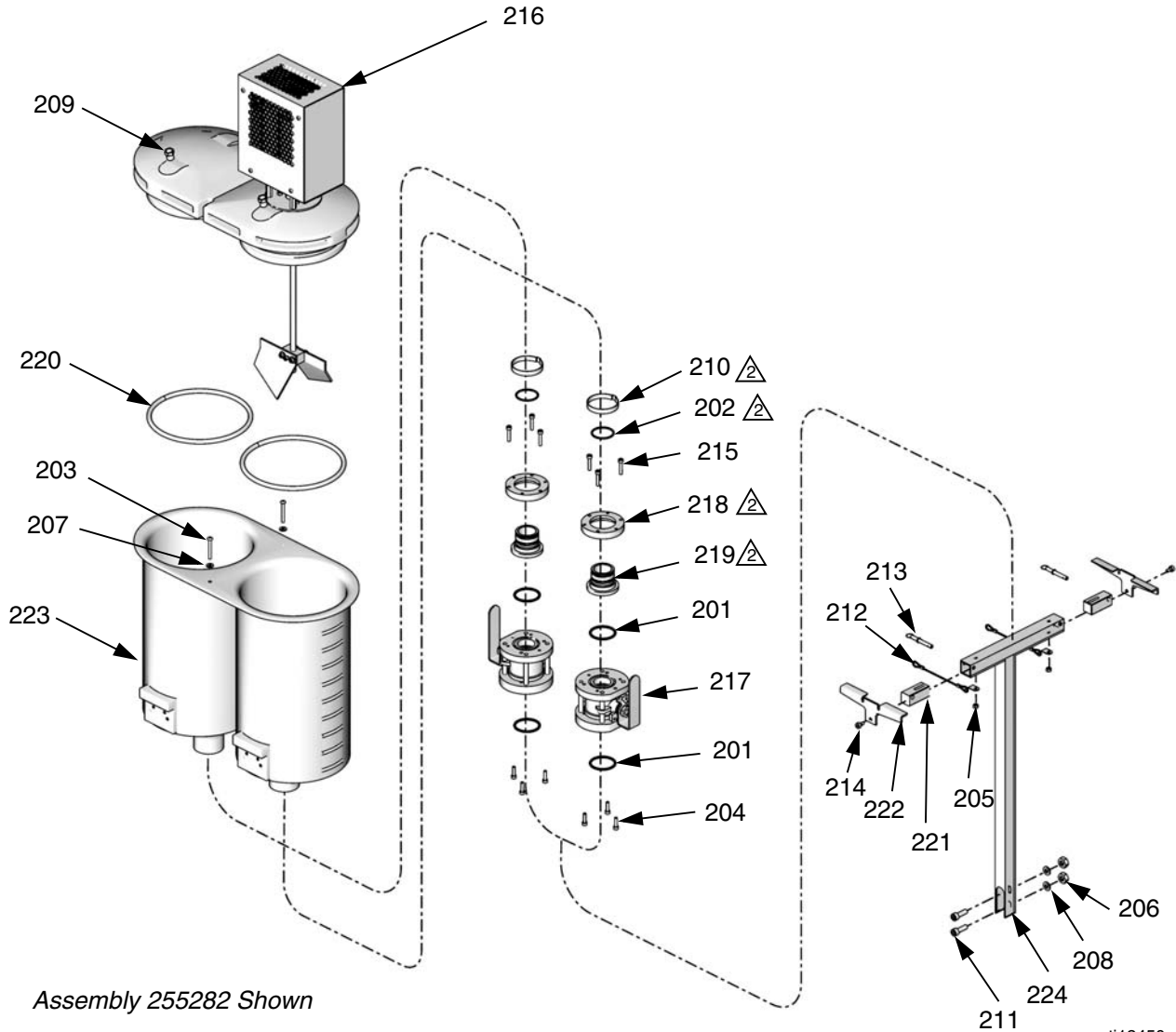

ti12450a

- ⚠ Apply thread sealant tape to male npt threads prior to installation.
- ⚠ Do not attempt to remove from tank. Disassembling will damage tank.

Ref	Part	Description	Quantity													
			255241, Tank	255281, Tank with Ball Valves	255282, Tank with Ball Valves and One 120V Agitator	255283, Tank with Ball Valves and Two 120V Agitators	255250, Tank with One 120V Agitator	255251, Tank with Two 120V Agitators	LC0126, Tank with One 240V Agitator	LC0127, Tank with Two 240V Agitators	LC0128, Tank with Ball Valves and One 240V Agitator	LC0129, Tank with Ball Valves and Two 240V Agitators	LC0156, Tank with One Pneumatic Agitator	LC0157, Tank with Two Pneumatic Agitators	LC0158, Tank with Ball Valves and One Pneumatic Agitator	LC0159, Tank with Ball Valves and Two Pneumatic Agitators
201	†◆** 95/0223/00	O-RING, fluoroelastomer, bbc	2	4	4	4	2	2	2	2	4	4	2	2	4	4
202	†◆*	O-RING	4	4	4	4	4	4	4	4	4	2	2	2	2	2
203	120902	SCREW, button head cap screw, M5 x 0.8 x 40 mm	2	2	2	2	2	2	2	2	2	2	2	2	2	2
204	†◆* 120904	SCREW, socket head cap, M5 x 0.8 x 18 mm	6	6	6	6	6	6	6	6	6	6	6	6	6	6
205	120905	NUT, HEX, lock M5 X 0.8	2	2	2	2	2	2	2	2	2	2	2	2	2	2
206	120906	NUT, HEX, lock M8 X 1.25	2	2	2	2	2	2	2	2	2	2	2	2	2	2
207	120907	WASHER, plain #10	4	2	2	2	2	2	2	2	2	2	2	2	2	2
208	120908	WASHER, plain M8	4	4	4	4	4	4	4	4	4	4	4	4	4	4
209	†◆* 120909	BREATHER	2	2	2	2	2	2	2	2	2	2	2	2	2	2
210	†◆*	CLAMP, gap-free pinch hose	2	2	2	2	2	2	2	2	2	2	2	2	2	2
211	120913	SCREW	2	2	2	2	2	2	2	2	2	2	2	2	2	2
212	120925	RETAINER, lanyard with tab			2	2	2	2	2	2	2	2	2	2	2	2
213	120927	FASTENER, quick-release pin			2	2	2	2	2	2	2	2	2	2	2	2
214	120929	SCREW, shoulder, M5 x 0.8 x 6 mm			2	2	2	2	2	2	2	2	2	2	2	2
215	121013 *	SCREW, M5 x 0.8 x 25 mm, socket head cap, stainless steel		6	6	6					6	6			6	6
216	255246	AGITATOR, 120V, assembly			1	2	1	2								
	255503	AGITATOR, 240V, assembly							1	2	1	2				
	255730	AGITATOR, pneumatic, assembly										1	2	1	2	
217	255280 *	VALVE, ball		2	2	2					1	2			2	2
218	†◆*	RING, lock	2	2	2	2	2	2	2	2	2	2	2	2	2	2
219	†◆*	FITTING, flange	2	2	2	2	2	2	2	2	2	2	2	2	2	2
220	†◆* 15K840	O-RING	2	2	2	2	2	2	2	2	2	2	2	2	2	2
221	15K882	RETAINER, slide, clamp, 8L PE tank			2	2	2	2	2	2	2	2	2	2	2	2
222	15K883	CLAMP, dual 8L PE tank			2	2	2	2	2	2	2	2	2	2	2	2
223	†	TANK, assembly	1	1												
	◆	TANK, assembly			1		1		1		1		1		1	
	*	TANK, assembly				1		1		1		1		1		1
224	15M226	BALLAST		1	1	1					1	1			1	1
	15K842	BALLAST	1				1	1	1	1			1	1		
225	**120915	CAP, plug, square	2	2												

* Parts included in kit 255481.

† Parts included in kit 255479.

◆ Parts included in kit 255480.

** Part not shown.

* Parts included in kit 26A300.

Polyethylene Tank Agitators

Electric Agitator Assemblies 255246 and 255503

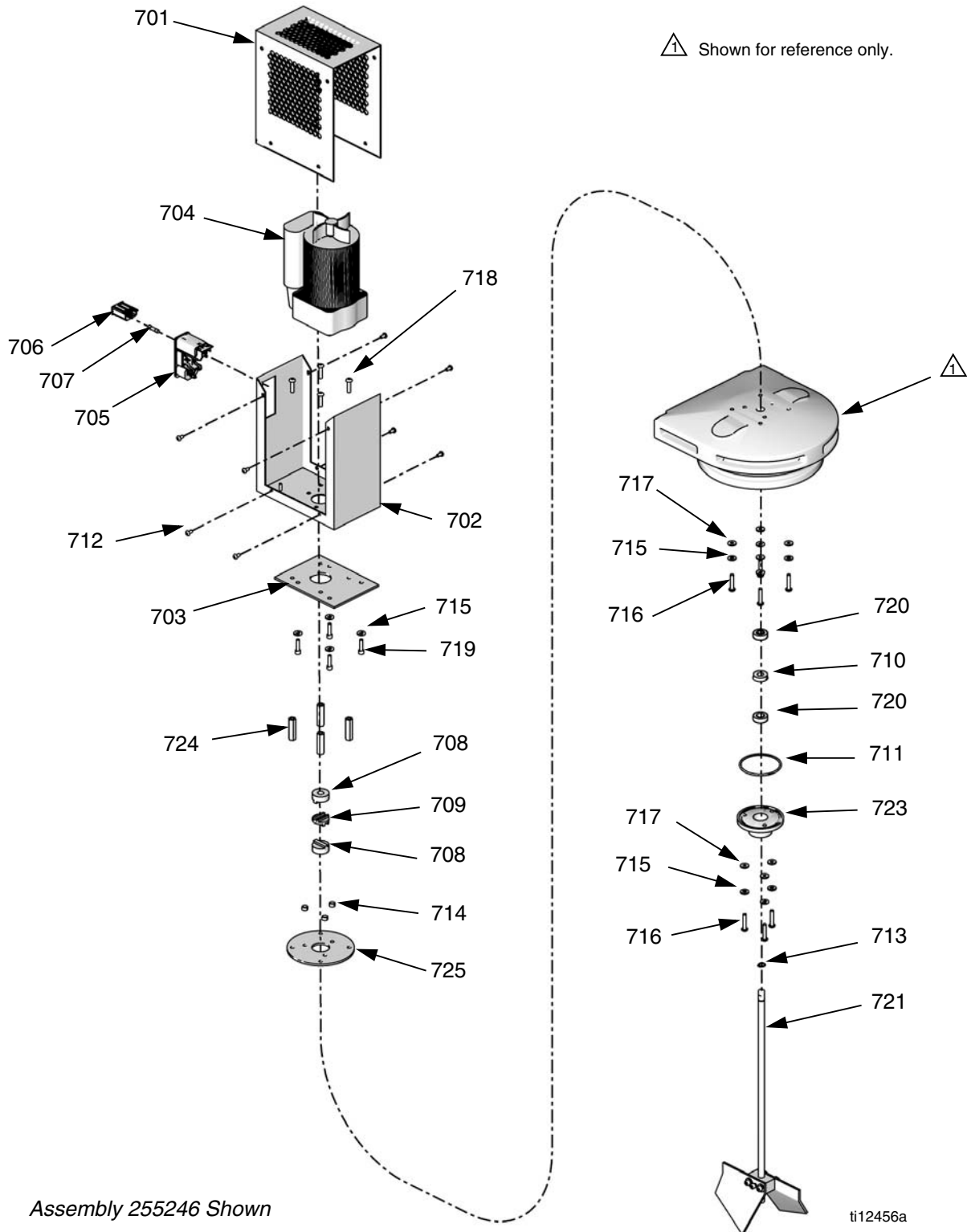

Assembly 255246 Shown

Ref	Part	Description	Qty
701	01/2218/97	ENCLOSURE, agitator, electric, prm/v/f, hd	1
703	01/2219/97	PLATE, adapter, electric agitator, hd, prm	1
704	81/2218-1/11	MOTOR, 50 rpm, 60 in-lb, 120V, 1.2A (assembly 255246 only)	1
	256613	MOTOR, 50 rpm, 60 in-lb, 230V (assembly 255503 only)	1
705	81/1040/11	MODULE, ac, 2p, 250V, 10a, double pull single throw, w/fuse	1
706	81/1040-1/11	MODULE, ac connector, 2P, 250V, 10A, with bar	1
707	81/1053-1.6/11	FUSE, 5 x 20 mm, 1.6A, time delay	1
708	84/2215-A/11	COUPLING, alignment, 1 in. OD, hub, 3/8 ID	2
709	84/2215-B/11	COUPLING, alignment, 1 in. OD, disk, nylon	1
710	95/0842/11	SEAL, posipak, 3/8ID x 7/8OD, P/fluoroelastomer	1
711	95/0864/00	O-RING, fluoroelastomer, ada	1
712	96/0271/99	FASTENER, button head cap screw, 8-32 x 0.31, mild steel	8
713	96/0817/99	RING, retaining, external, 0.375, mild steel	1
714	120905	NUT, hex, lock M5 x 0.8	3
715	120907	WASHER, plain #10	11
716	120928	SCREW, button head cap screw, M5 x 0.8 x 25 mm	7
717	120930	WASHER, seal, fluoroelastomer	7
718	120960	SCREW, button head cap screw, M5 x 0.8 x 20 mm, stainless steel	4
719	120961	SCREW, button head cap screw, 10-32 x 1.25 in., stainless steel	4
720	121173	BEARING, ball, 3/8 in. ID x 7/8 in. OD x 9/32 in.	2
721	255724	AGITATOR, shaft and blade assy	1
723	15K884	HOUSING, bearing	1
724	15K885	SPACER, agitator standoff	4
725	15K886	DISK, bearing	1
726	† 121599	CORD, power, v-lock, C14/C13, 10A	1

† Part not shown.

Pneumatic Agitator Assembly 255730

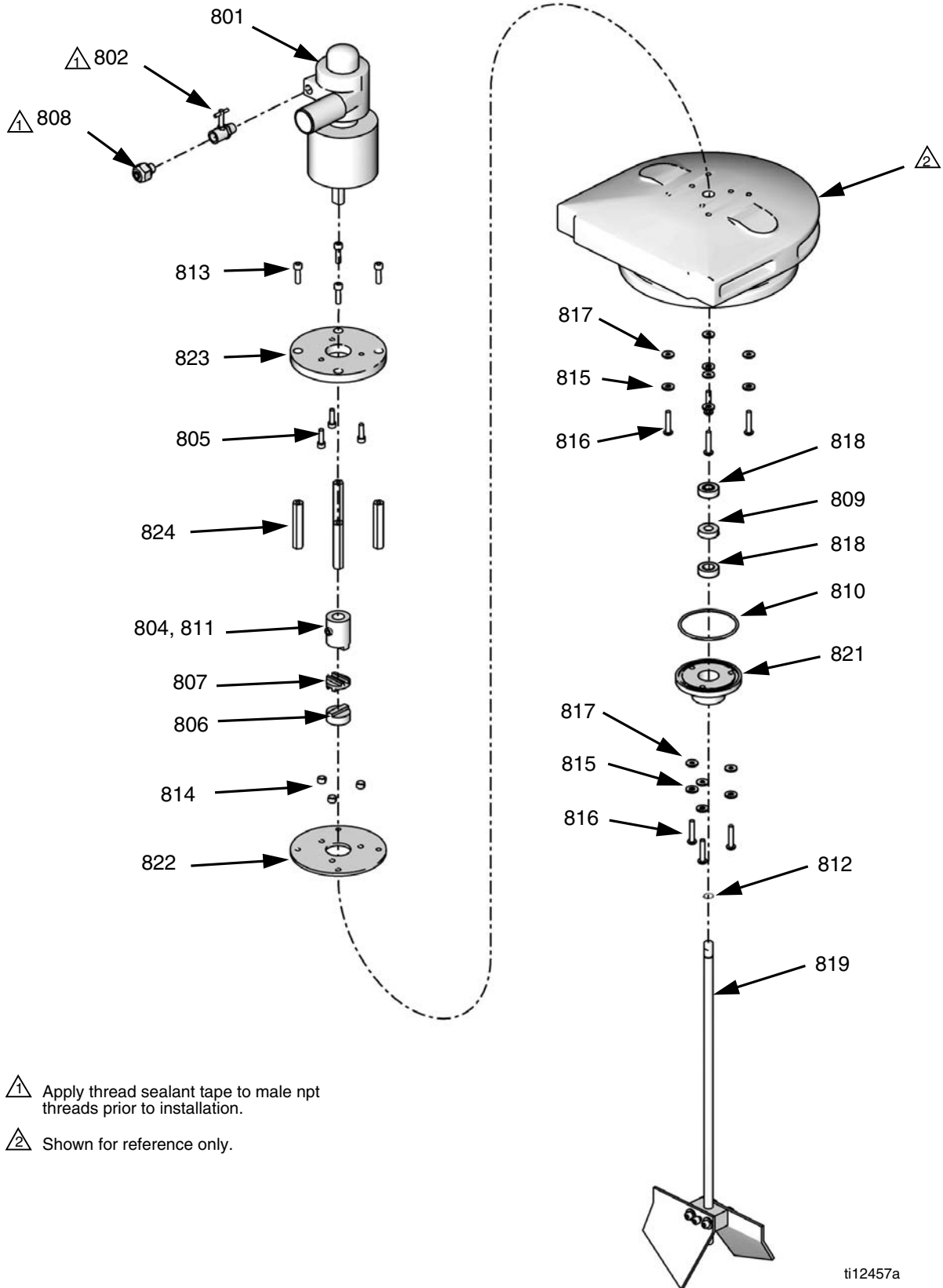

Ref	Part	Description	
801	82/0216/11	MOTOR, motor, pneumatic, agitator, 0.32 hp	1
802	94/0838/96	VALVE, needle, 1/8 npt x 1/8 npt, male / female	1
804	01/1189/98	ADAPTER, coupling, air motor, agitator	1
805	5-01-0510	SCREW, socket head cap, 10-32 x 5/8 in.	3
806	84/2215-A/11	COUPLING, alignment, 1 in. OD, hub, 3/8 in. ID	1
807	84/2215-B/11	COUPLING, alignment, 1 in. OD, disk, nylon	1
808	94/0702/96	FITTING, 1/4 tube x 1/8 npt, male, brass	1
809	95/0842/11	SEAL, posipak, 3/8ID x 7/8OD, P/fluoroelastomer	1
810	95/0864/00	O-RING, fluoroelastomer, ADA	1
811	96/0029/99	SCREW, socket head, 5/16-24 x 0.25, cup point	1
812	96/0817/99	RING, retaining, external, 0.375, mild steel	1
813	120904	SCREW, socket head cap, M5 x 0.8 x 18 mm	4
814	120905	NUT, hex, lock M5 x 0.8	3
815	120907	WASHER, plain #10	7
816	120928	SCREW, button head cap screw, M5 x 0.8 x 25 mm	7
817	120930	WASHER, seal, fluoroelastomer	7
818	121173	BEARING, ball, 3/8 in. ID x 7/8 in. OD x 9/32 in.	2
819	255724	AGITATOR, shaft and blade assy	1
821	15K884	HOUSING, Bearing	1
822	15K886	DISK, bearing	1
823	15R363	ADAPTER, plate, pneumatic agitator	1
824	15R364	SPACER, standoff, pneumatic agitator	4

Agitator Shaft, 255724

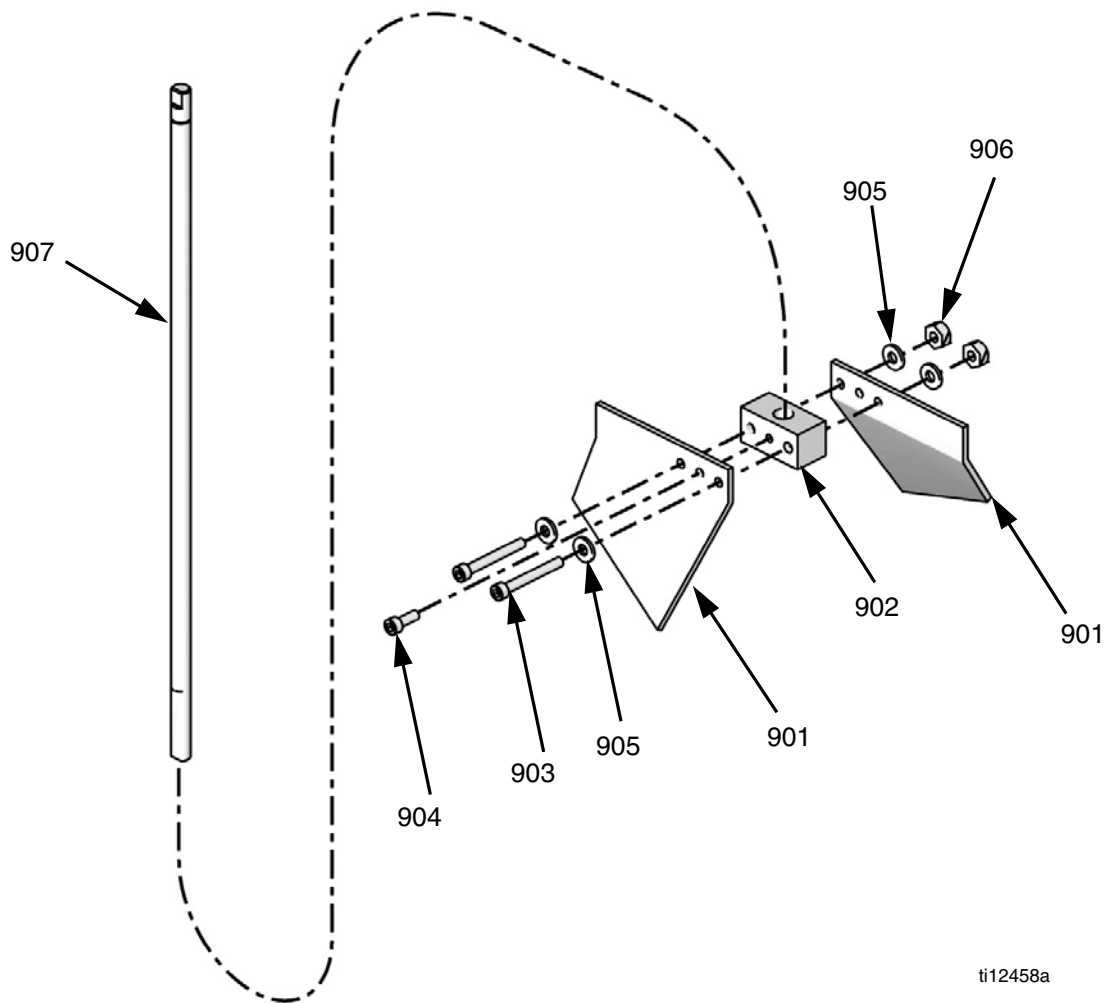

ti12458a

Ref	Part	Description	Qty
901	01/2230-1/98	PADDLE, agitator, tfm tank, stainless steel	2
902	01/2230-2/98	SUPPORT, mount, paddle, agitator	1
903	96/0097/98	FASTENER, screw, socket head cap, 10-24 x 1.25, stainless steel	2
904	96/0125/98	FASTENER, screw, socket head cap, 10-24 x 0.50, stainless steel	1
905	96/0129/98	WASHER, flat, SAE, #10, stainless steel, 1/2 in. OD, 0.049	4
906	96/0304-4/98	NUT, hex, lock, 10-24, stainless steel	2
907	15R307	SHAFT, agitator, 8L polyethylene tanks	1

On-Board Stainless Steel Tanks

Tank Assemblies LC0237, LC0238, LC0254, and LC0255

 Right hand tank shown, left hand tank is mirror image.

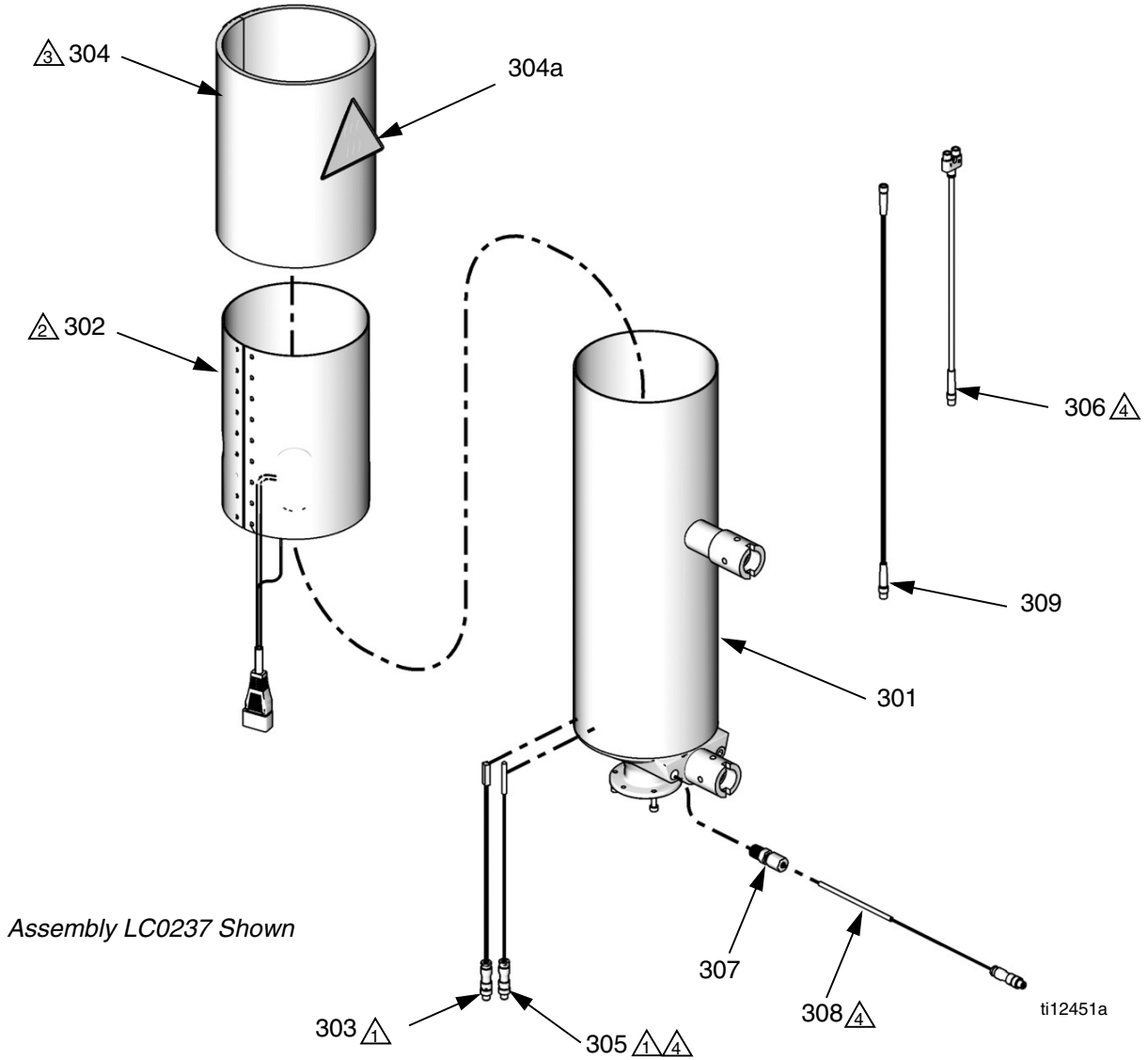

- ① Use glass cloth tape to secure ground strap, thermal switch, and RTD to tank wall before adding heat blanket.
- ② Secure heat blanket to tank with string laced through eyelets.
- ③ Insulation blanket should cover heat blanket completely. Secure insulation blanket to tank with 2 in. wide velcro strap.
- ④ The RTD sensor assembly (308) should always be connected to side one of the M8 splitter harness (306). Side one is on the female/female end of connector and is marked with a molded imprint of the number "1". The RTD sensor assembly (305) should always be connected to side two of the M8 splitter harness (306).

Parts

Ref	Part	Description	Qty
301	---	Refer to Tanks for Use with Dust Covers and Tanks for Use with Clampdown Covers , page 44, for replacement or spare parts.	1
302	LC0861	BLANKET, heat, 7.5L tank, 220V	1
303	256558	SWITCH, assy, thermal, 125C, 3P, M8	1
304	LC0056	BLANKET, insulation	1
304a	▲ 121208	LABEL, hot surface	
305	256611	SENSOR, assy, 1.5 in. rtd, 4-pin M8	1
306	121615	HARNESS, splitter, M8, 4-pin, female/male, 3 m	1
307	121478	FITTING, compression, 3/16 x 1/4 npt	1
308	256612	SENSOR, assy, 4.25 in. rtd, 4-pin M8	1
309	121682	CABLE, M8, 3-pin, male / female, 3 meter, molded	1
310	† 121633	CIRCUIT, breaker, 2-pole, 4A, C type	1

† Not shown. See *Integrated Heat* manual referenced at beginning of this manual.

▲ Replacement Danger and Warning labels, tags, and cards are available at no cost.

Tank Assemblies 255284, 255285, LC0235, LC0236, LC0012, and LC0013

 It is recommended that the flat face of the tank faces the back of the base machine. Right hand tank shown, left hand tank is mirror image.

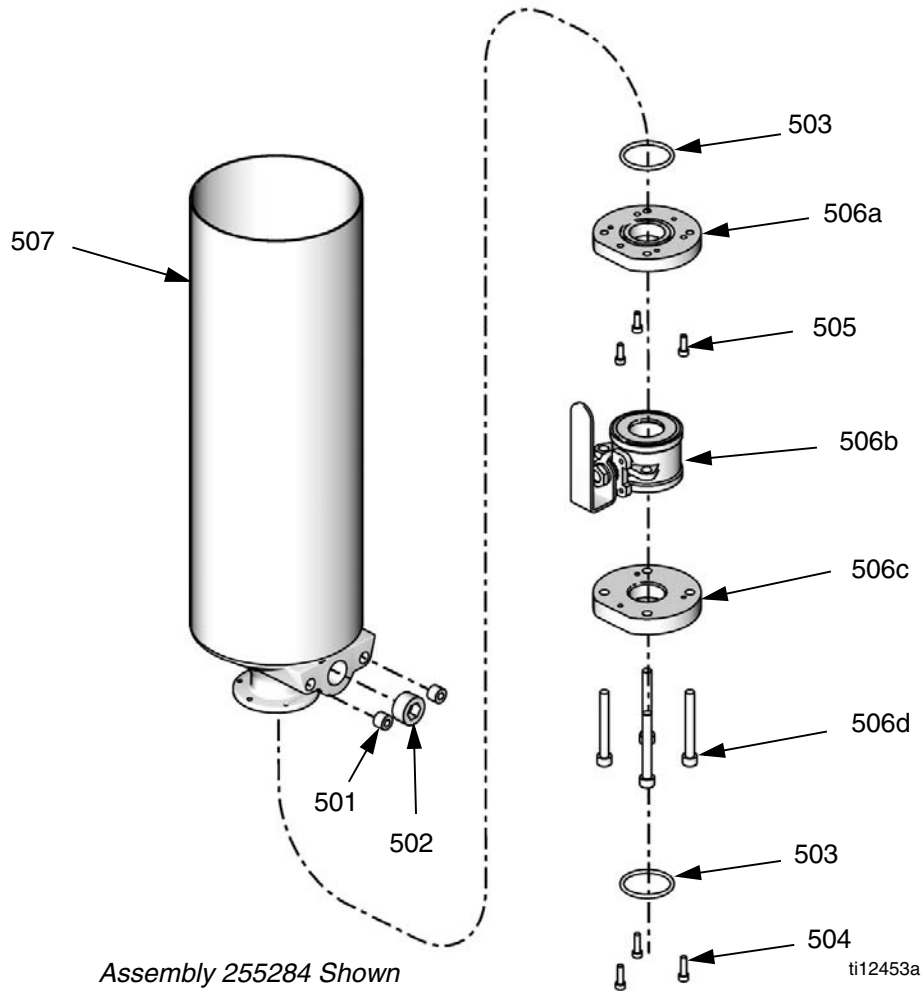

Assembly 255284 Shown

Ref	Part	Description	Qty	Ref	Part	Description	Qty
501	94/0370/98	PLUG, socket head, 1/4 npt, stainless steel	2	506†*	255280	VALVE, ball, shutoff (assemblies 255284, 255285, LC0235, and LC0236 only)	1
502	94/0372/98	PLUG, socket head, 3/4 npt, stainless steel	1	507	---	Refer to Tanks for Use with Dust Covers and Tanks for Use with Clampdown Covers , page 44, for replacement or spare parts.	1
503*	95/0223/00	O-RING, fluoroelastomer, bbc	2				
504	120904	SCREW, socket head cap, M5 x 0.8 x 18mm	3				
505*	121011	SCREW, M5 x 0.8 x 14mm, socket head cap, stainless steel (assemblies 255284, 255285, LC0235, and LC0236 only)	3				

† See **Ball Valve, Assembly 255280**, page 40 for parts information.

* Parts included in kit 26A300.

Ball Valve, Assembly 255280

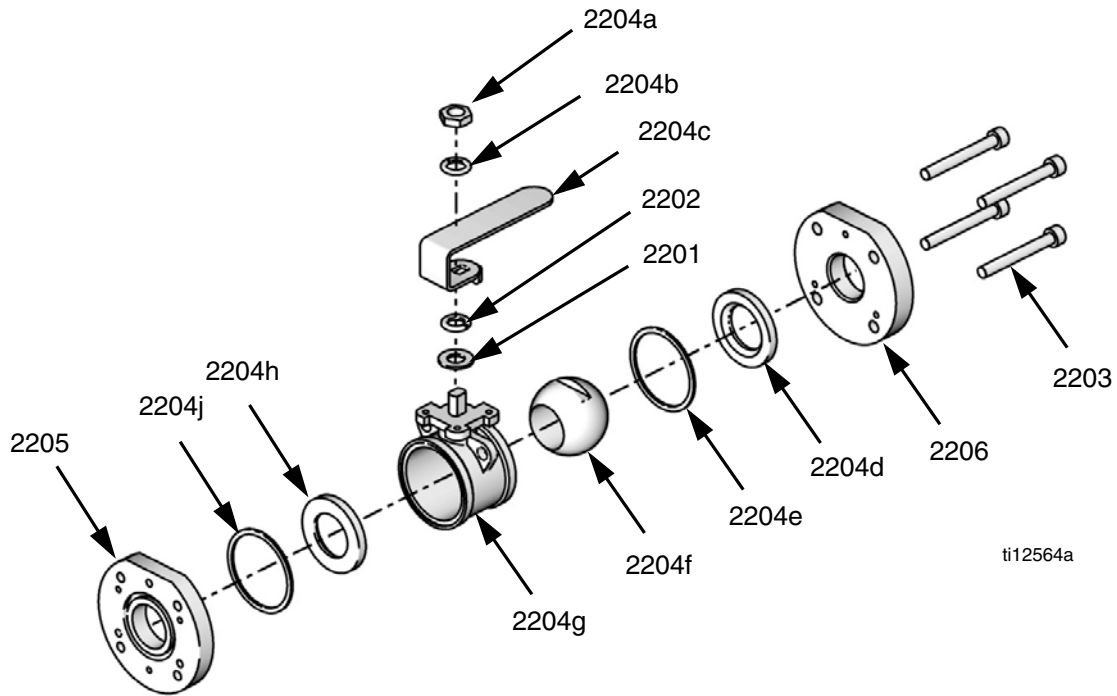

Ref	Part	Description	Qty
2201	96/0075-1/99	WASHER, flat, sae, 7/16, mild steel, n series	1
2202	96/0075/99	WASHER, lock, split, 7/16, mild steel	1
2203	121012	SCREW, M8 x 1.25 65 mm, socket head cap screw, stainless steel	4
2204	121111	VALVE, ball, 3 piece, 1-1/4 in. fp	1
2205	15M224	FLANGE, plate, top	1
2206	15M225	FLANGE, plate, bottom	1

Flange Assembly, 256896

The flange assembly can be installed if no tanks or accumulators are installed. It allows for other feed system options to be installed onto the pump subassembly.

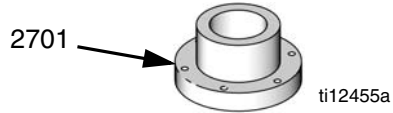

Ref	Part	Description	Qty
2701	15M237	Flange, 1-1/2 in. npt	1
2702	* 95/0223/00	O-RING, fluoroelastomer, bbc	1
2703	* 120904	SCREW, socket head cap, M5 x 0.8 x 18 mm	3

* Part not shown.

On-Board Stainless Steel Tank Lids

Lid Assemblies LC0019 to LC0026 and LC0130 to LC0132

CAUTION
The electric agitators used with on-board tanks will fail prematurely when material viscosity exceeds 24,000 cps. Use pneumatic agitators if material viscosity exceeds 24,000 cps.

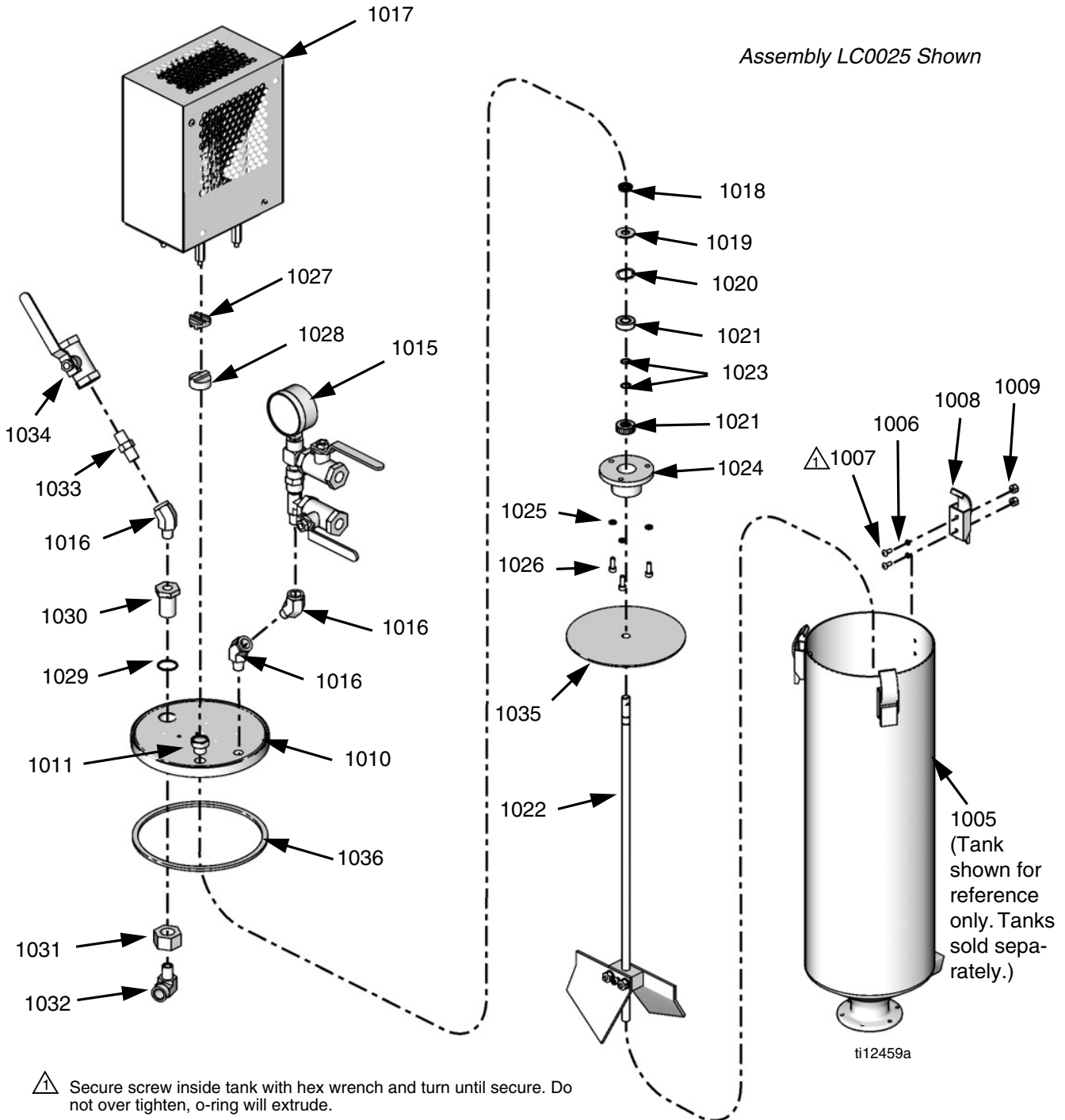

Ref	Part	Description	Quantity										
			LC0019, Lid assembly with Relief	LC0020, Lid assembly	LC0021, Lid assembly, 120 V Agitator	LC0022, Lid assembly, 240 V Agitator	LC0023, Lid assembly, Agitator, De-gas	LC0024, Lid assembly, Agitator, De-gas	LC0025, Lid assembly, Agitator, De-gas, Fill Port	LC0026, Lid assembly, Agitator, De-gas, Fill Port	LC0130, Lid Assembly, Pneumatic Agitator	LC0131, Clamp Down Lid, Pneumatic Agitator, De-gas	LC0132, Clamp Down Lid, Pneumatic Agitator, Fill Port
1005	---	Reference Only. Tank sold separately.‡	-	-	-	-	-	-	-	-	-	-	-
1006	95/0518/00	O-RING, fluoroelastomer, JJF	6	6	6	6	6	6	6	6	6	6	6
1007	96/0282/98	FASTENER, screw, button head cap screw, 8-32 x 0.38, stainless steel	6	6	6	6	6	6	6	6	6	6	6
1008	96/0820/98	CLAMP, over the center, stainless steel	3	3	3	3	3	3	3	3	3	3	3
1009	96/0176-1/98	NUT, lock, 8-32, nylock, stainless steel	6	6	6	6	6	6	6	6	6	6	6
1010	15M320	LID, 7L, 2 npt, 1 9/16-32	1	1									
	15M321	LID, 7L, 2 npt, 1 9/16-32, agitator			1	1	1	1			1	1	
	15M322	LID, 7L, 2 npt, 9/16-32, agitator, fill port							1	1			1
1011	94/0752-D/97	VALVE, relief, 9/16-32, 5 psi	1	1	1	1	1	1	1	1	1	1	1
1012	†94/0736/96	VALVE, drain cock, 1/4 npt, male, brass	1		1	1					1		
1013	†94/0370/98	PLUG, socket head, 1/4 npt, stainless steel	1	1	1	1	1	1			1	1	
1014	†121090	FITTING, 1/4 npt expander		1									
1015	255342	MANIFOLD, vacuum tree		1			1	1	1	1		1	1
1016	94/0299/98	FITTING, elbow, str, 1/4 npt, 45, 3K			1	1	2	2	2	3	1	2	3
1017	255337	AGITATOR, motor assembly, 120V			1		1		1				
	255338	AGITATOR, motor assembly, 240V				1		1		1			
	02/1116/50	AGITATOR, assembly, pneumatic, TFM, 0.32 HP, 15:1									1	1	1
1018	95/0849/11	SEAL, posipak, 3/8 ID x 5/8 OD			1	1	1	1	1	1	1	1	1
1019	96/0733/87	WASHER, 3/8 x 7/8 x 0.062, PTFE			1	1	1	1	1	1	1	1	1
1020	97/2215/98	SPRING, wave, 0.86 x 0.65 x 0.010, stainless steel			1	1	1	1	1	1	1	1	1
1021	84/0120/98	BEARING, ball, 0.375ID, DS			2	2	2	2	2	2	2	2	2
1022	255339	AGITATOR, blade assembly			1	1	1	1	1	1	1	1	1
1023	96/0817/99	RING, retaining, external, 0.375, mild steel			2	2	2	2	2	2	2	2	2
1024	01/2212/70	HOUSING, bearing, electric agitator			1	1	1	1	1	1	1	1	1
1025	96/0005/98	WASHER, lock, #10, stainless steel			3	3	3	3	3	3	3	3	3
1026	96/0125/98	FASTENER, screw, socket head cap, 10-24X0.50, stainless steel			3	3	3	3	3	3	3	3	3
1027	84/2215-B/11	COUPLING, alignment, 1 in. OD, disk, nylon			1	1	1	1	1	1	1	1	1
1028	84/2215-A/11	COUPLING, alignment, 1 in. OD, hub, 3/8 ID			1	1	1	1	1	1	1	1	1
1029	95/0117/00	O-RING, fluoroelastomer, jai							1	1			1
1030	01/1174-3/97	BULKHEAD, 1/4 npt, tank lid, thin, tfm							1	1			1
1031	96/0056/98	NUT, hex, jam, 3/4-16, stainless steel							1	1			1
1032	94/0300-1/98A	FITTING, elbow, STRT, 90, 1/4 npt, male / female							1	1			1
1033	94/0320-1/99	FITTING, nipple, hex, 1/4npt, 5K, mild steel							1	1			1
1034	94/0900-R2/98	VALVE, ball, 2W, 1/4npt, female, 2000 psi							1	1			1
1035	87/0220-2/98	PLATE, slinger, tfm, 3/8ID, 5-1/2OD							1	1			1
1036	95/0524/01	GASKET, lid, tfm, nit	1	1	1	1	1	1	1	1	1	1	1

† Part not shown.

‡ Spare clamps will be provided with all clamp-down lid assemblies.

Tanks for Use with Dust Covers

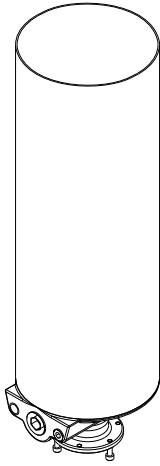

LC0012
7.5 L stainless steel

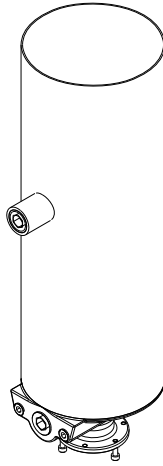

LC0235
7.5 L stainless steel
with high level port

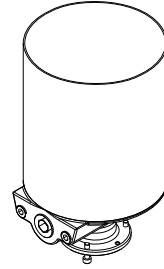

LC0013
3 L stainless steel

Tanks for Use with Clampdown Covers

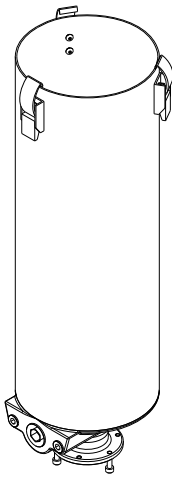

24U714
7.5 L stainless steel
with clamps

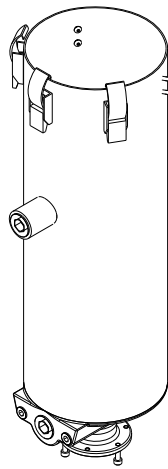

24U713
7.5 L stainless steel
with high level port
and clamps

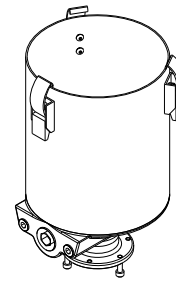

24U715
3 L stainless steel
with clamps

 Ball valve shutoff assemblies and mounting hardware must be ordered separately.

Lid Assembly LC0018

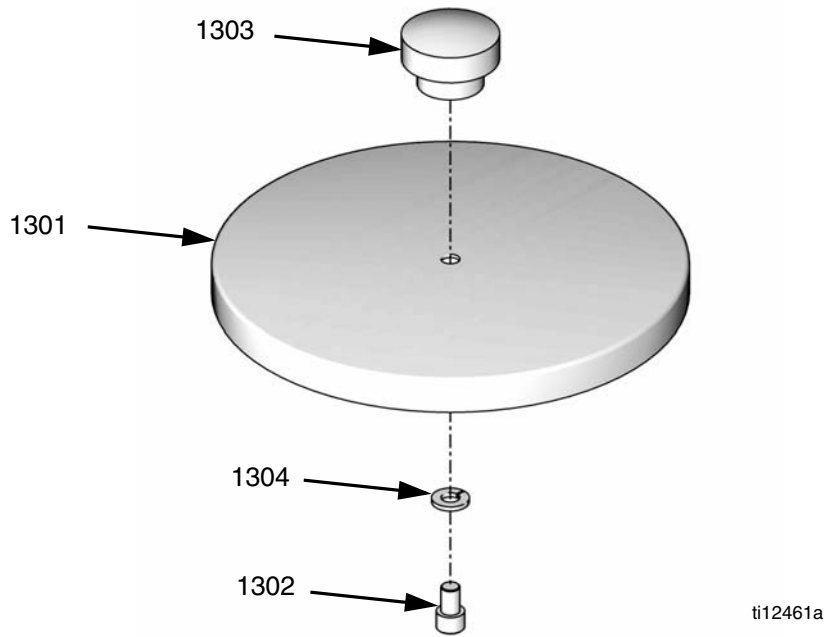

⚠ Apply thread sealant tape to male npt threads prior to installation.

Ref	Part	Description	Qty
1301	15M956	LID, mod, 7.5L & 3L, stainless steel	1
1302	96/0127/98	FASTENER, socket head cap screw, 1/4-20 x 0.37, stainless steel	1
1303	96/0148/11	KNOB, 1/4-20, female, plastic	1
1304	96/0311/98	WASHER, lock, 1/4, hc, stainless steel	1

Off-Board Stainless Steel Tanks

Tank Assemblies

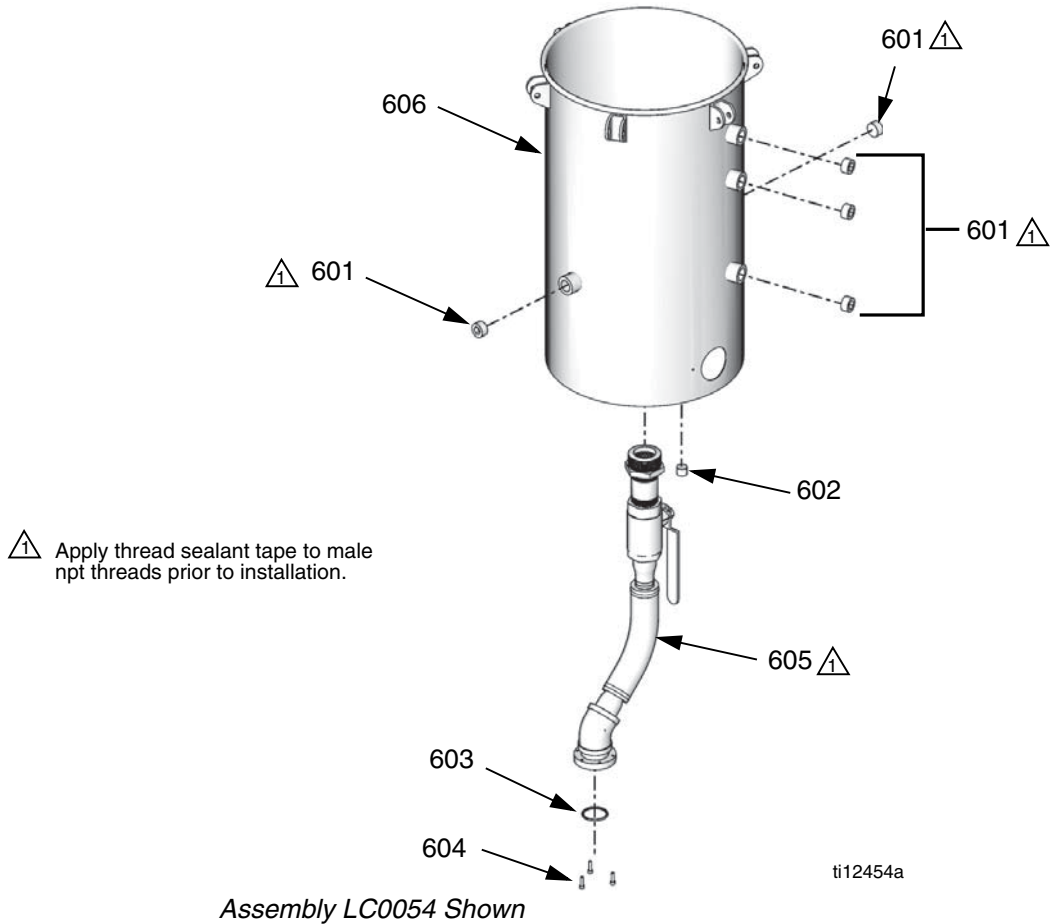

Ref	Part	Description	Qty
601	111384	PLUG, pipe	5
602	103778	PLUG, pipe, headless	1
603	108832	O-RING	1
604	120904	SCREW, socket head cap, M5 x 0.8 x 18 mm	3
605	255391	SYSTEM, pipe and tube, 1-1/2 in.	1
606	†	TANK, 30 L, stainless steel	1
	◆	TANK, 60 L, stainless steel	1
	❖	TANK, 30 L, stainless steel, agitator	1
	✱	TANK, 60 L, stainless steel, agitator	1

† Parts can be purchased in Tank Kit 255389 which includes the tank body, a basic tank lid with clamps, lid plug fittings, and a tank lid gasket.

◆ Parts can be purchased in Tank Kit 256633 which includes the tank body, a basic tank lid with clamps, lid plug fittings, and a tank lid gasket.

❖ Parts can be purchased in Tank Kit 17S473 which includes the tank body, an agitator tank lid with clamps, lid plug fittings, and a tank lid gasket.

✱ Parts can be purchased in Tank Kit 17S584 which includes the tank body, an agitator tank lid with clamps, lid plug fittings, and a tank lid gasket.

Tank Assemblies

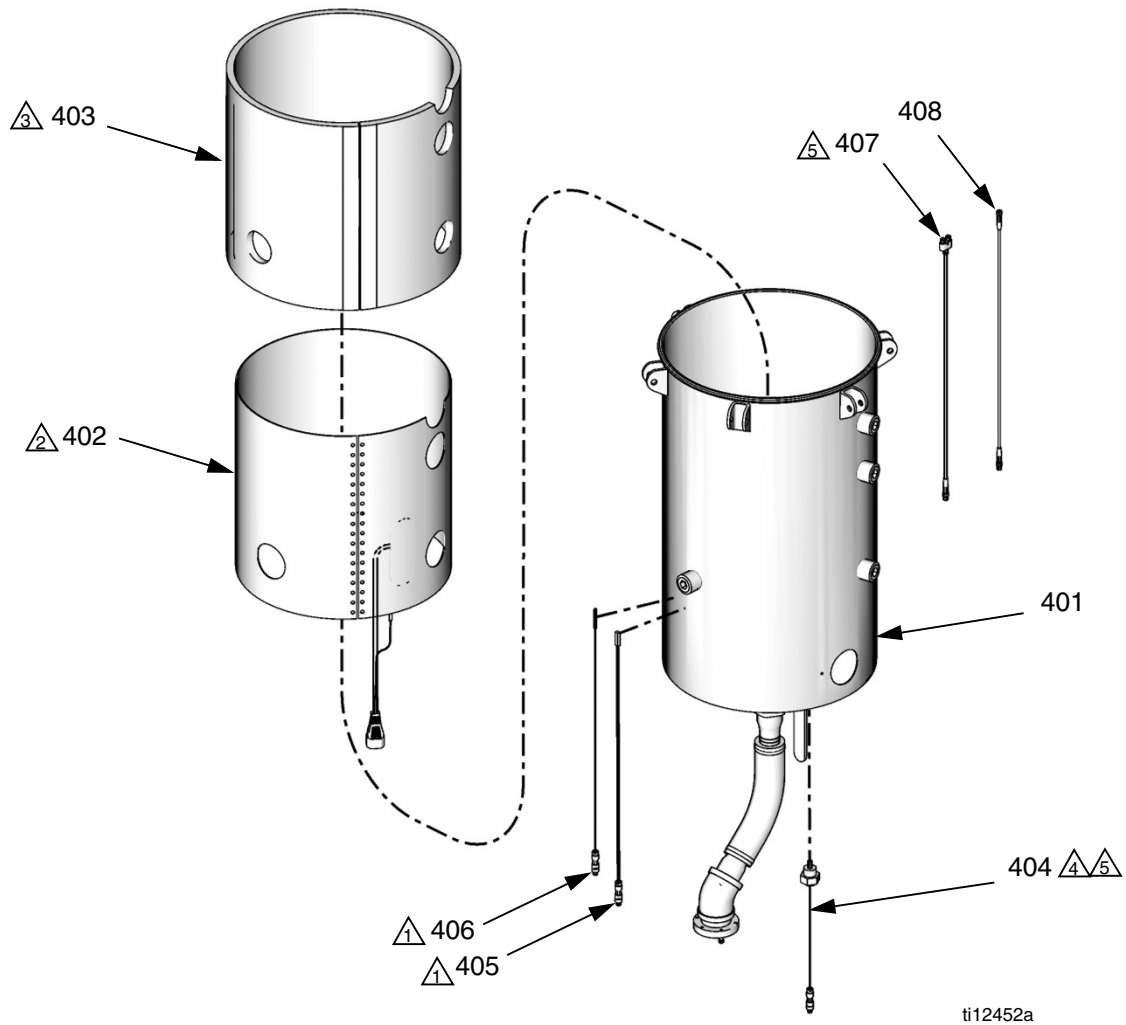

- ① Use glass cloth tape to secure ground strap, thermal switch, and RTD to tank wall before adding heat blanket.
- ② Secure heat blanket to tank with string laced through eyelets.
- ③ Insulation blanket should cover heat blanket completely. Secure insulation blanket to tank with 2 in. wide velcro strap.
- ④ Apply thread sealant tape to male npt threads prior to installation.
- ⑤ The RTD sensor assembly (404) should always be connected to side one of the M8 splitter harness (407). Side one is on the female/female end of connector and is marked with a molded imprint of the number "1".

ti12452a

Pipe and Tube System, 255391

Ref	Part	Description	Qty
401	---	TANK, assy, 30 L, stainless steel	1
	---	TANK, assembly, 60 L, stainless steel	
402	LC0257	BLANKET, assy, heat, 30L, 240V, GCA	1
	LC0258	BLANKET, assy, heat, 60L, 240V, GCA	
403	257757	INSULATOR, blanket assy, 38 L	1
	257758	INSULATOR, blanket assy, 75 L	
403a	▲121208	LABEL, hot surface	1
404	257759	SENSOR, thermowell assy, RTD	1
405	256611	SENSOR, assy, 1.5 in. rtd, 4-pin M8	1
406	256558	SWITCH, assy, thermal, 125C, 3P, M8	1
407	121615	HARNESS, splitter, M8, 4-pin female/female/male, 3M	1
408	121682	CABLE, M8, 3-pin, male/female, 3 meter, molded	1
410	†121635	CIRCUIT, breaker, 2-pole, 13A, C type	1

† Not shown. See Integrated Heat manual referenced at the beginning of this manual.

▲ Replacement Danger and Warning labels, tags, and cards are available at no cost.

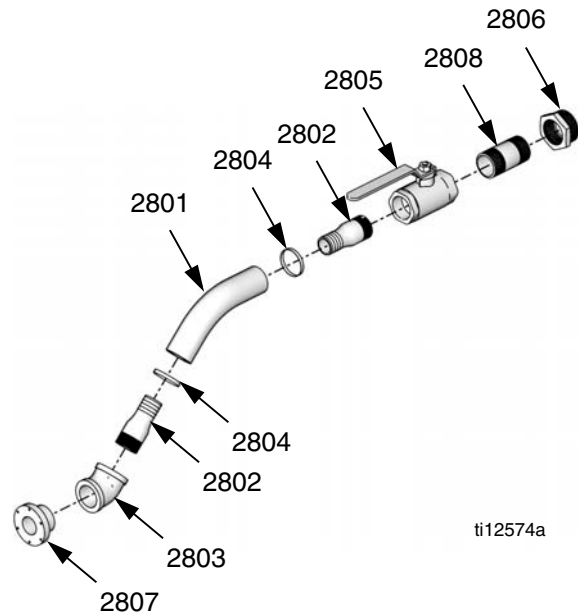

⚠ Apply thread sealant tape to all male npt threads.

Ref	Part	Description	Qty
2801	61/0056/88	HOSE, chemical, polyethylene, 1-1/2 in.	1
2802	94/0910/98	FITTING, barb, 1-1/2 x 1-1/2 NPT, male, stainless steel	2
2803	94/1081/98	FITTING, elbow, 1-1/2 in., female, 45 deg, stainless steel	1
2804	94/0414/99	CLAMP, hose, 2-1/4 in. - 1-5/16 in., mild steel	2
2805	121135	VALVE, ball, 1-1/2 NPT full port	1
2806	121136	BUSHING, hex, 2 in. NPT x 1-1/2 in. NPT	1
2807	15M237	FLANGE, 1-1/2 in. NPT	1
2808	15R536	FITTING, nipple, 1.5 NPT x 3 in., stainless steel	1

Off-Board Stainless Steel Tank Lids

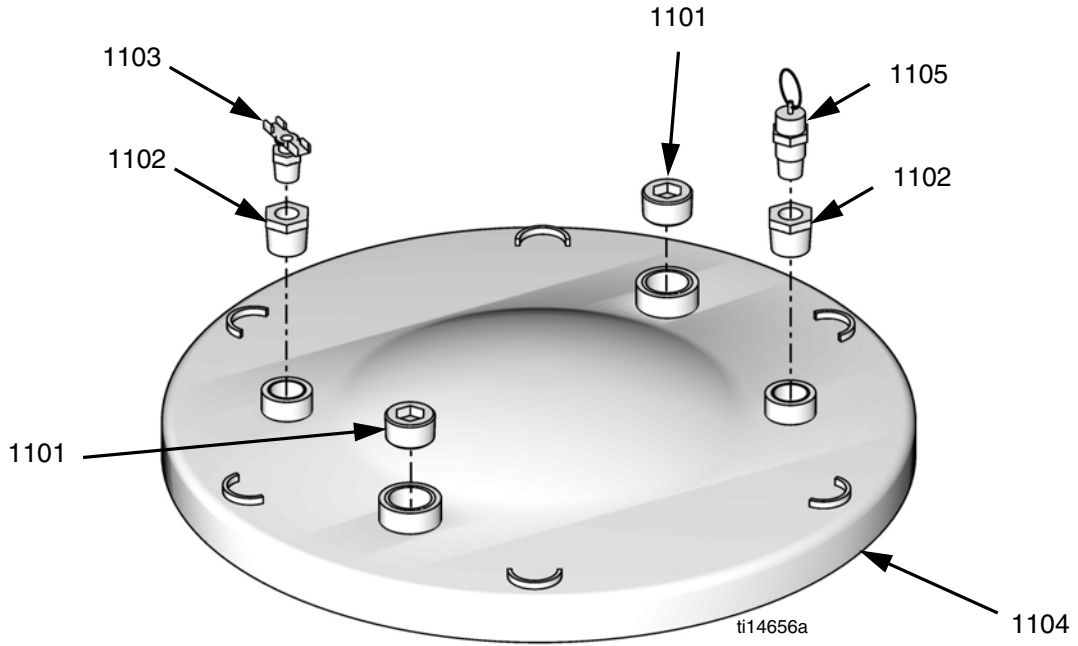

⚠ Apply thread sealant tape to all pipe threads.

Ref	Part	Description	Qty
1101	111384	PLUG, pipe	2
1102	122767	BUSHING, 1/2 npt x 1/4 npt, stainless steel	2
1103	94/0736/96	VALVE, drain cock, 1/4 npt, male, brass	1
1104	---	LID, stainless steel	1
1105	15R145	VALVE, relief, 1/4 npt, male, 40 psi, sil	1

Lid Assembly Vacuum

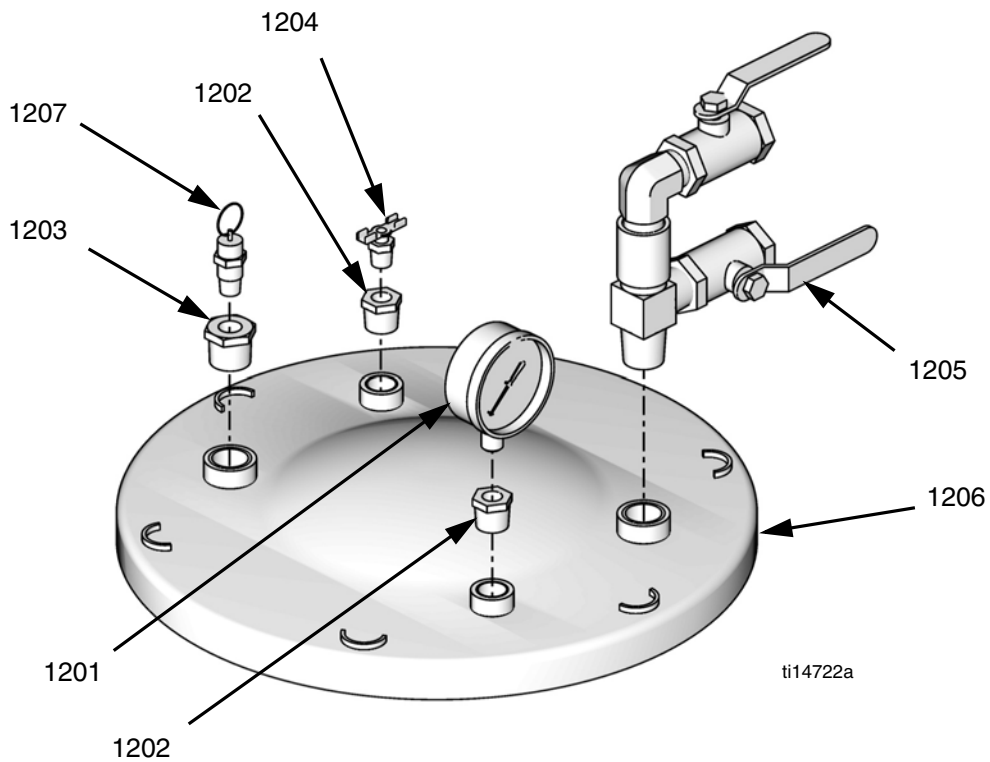

⚠ Apply thread sealant tape to male npt threads prior to installation.

Ref	Part	Description	Qty
1201	187875	GAUGE, pressure, fluid	1
1202	122767	BUSHING, 1/2 npt x 1/4 npt, stainless steel	2
1203	15M861	FITTING, reducer, pipe, 3/4 x 1/4, stainless steel	1
1204	94/0736/96	VALVE, drain cock, 1/4 npt, male, brass	1
1205	257746	FITTING, vacuum tree	1
1206	---	LID	1
1207	15R145	VALVE, relief, 1/4 npt, male, 40 psi, sil	1

Lid Assemblies Pneumatic Agitator

CAUTION

The electric agitators used with off-board tanks will fail prematurely when material viscosity exceeds 48,000 cps. Use pneumatic agitators if material viscosity exceeds 48,000 cps.

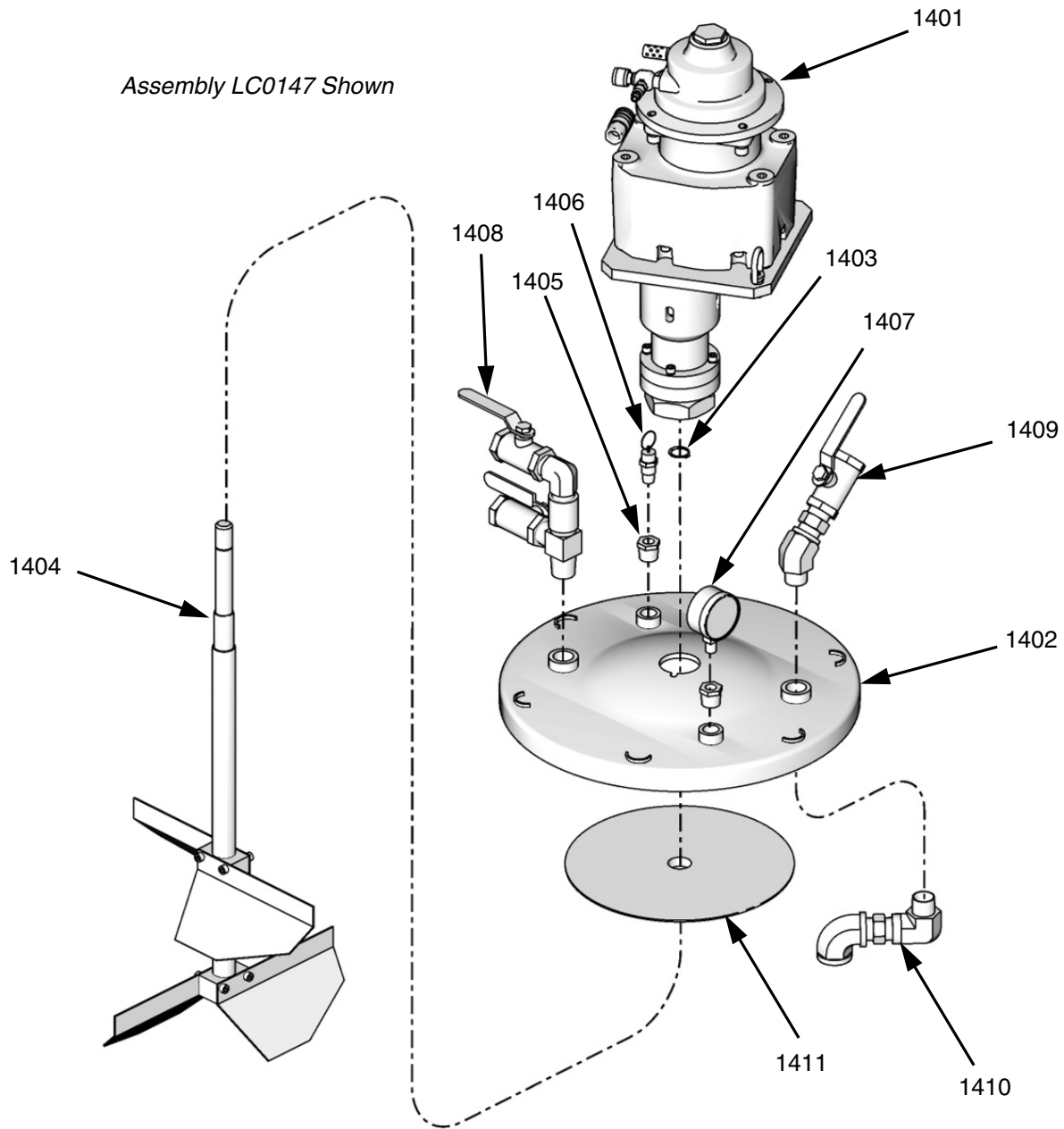

ti12460b

 Apply thread sealant tape to male npt threads prior to installation.

Ref	Part	Description	Quantity				
			60 L, Agitator, Vacuum De-gas	Pneumatic Agitator, De-gas	Pneumatic Agitator, De-gas, 60 L	Pneumatic Agitator, De-gas, Fill Port, 30 L	Pneumatic Agitator, De-gas, Fill Port, 60 L
1401◆	24J183	AGITATOR		1	1	1	1
	256822	MOTOR, single phase, 50/60 hz	1				
1402	---	LID, agitator	1	1	1	1	1
1403	122776	RING, retaining, external, 0.750, mild steel	1	1	1	1	1
1404	257607	AGITATOR, blade assem- bly		1		1	
	257608	AGITATOR, blade assem- bly	1		1		1
1405	122767	BUSHING, 1/2 x 1/4 npt, male / female, stainless steel, 6K, 316	2	2	2	2	2
1406	15R145	VALVE, relief, 1/4 npt, male, 40 psi, sil	1	1	1	1	1
1407	187875	GAUGE, pressure, fluid	1	1	1	1	1
1408	257746	FITTING, vacuum tree	1	1	1	1	1
1409	257602	VALVE, assembly, ball, fill, lid, 3/4, stainless steel				1	1
	111384	PLUG, pipe	1	1	1		
1410	255747	FITTING				1	1
1411	257606	PLATE, slinger				1	1

◆ Previous versions of these lid assemblies include agitator 255670 but that agitator is no longer available. Agitator kit 24J182 is the replacement for 255670.

Lid Assemblies

CAUTION

The electric agitators used with off-board tanks will fail prematurely when material viscosity exceeds 48,000 cps. Use pneumatic agitators if material viscosity exceeds 48,000 cps.

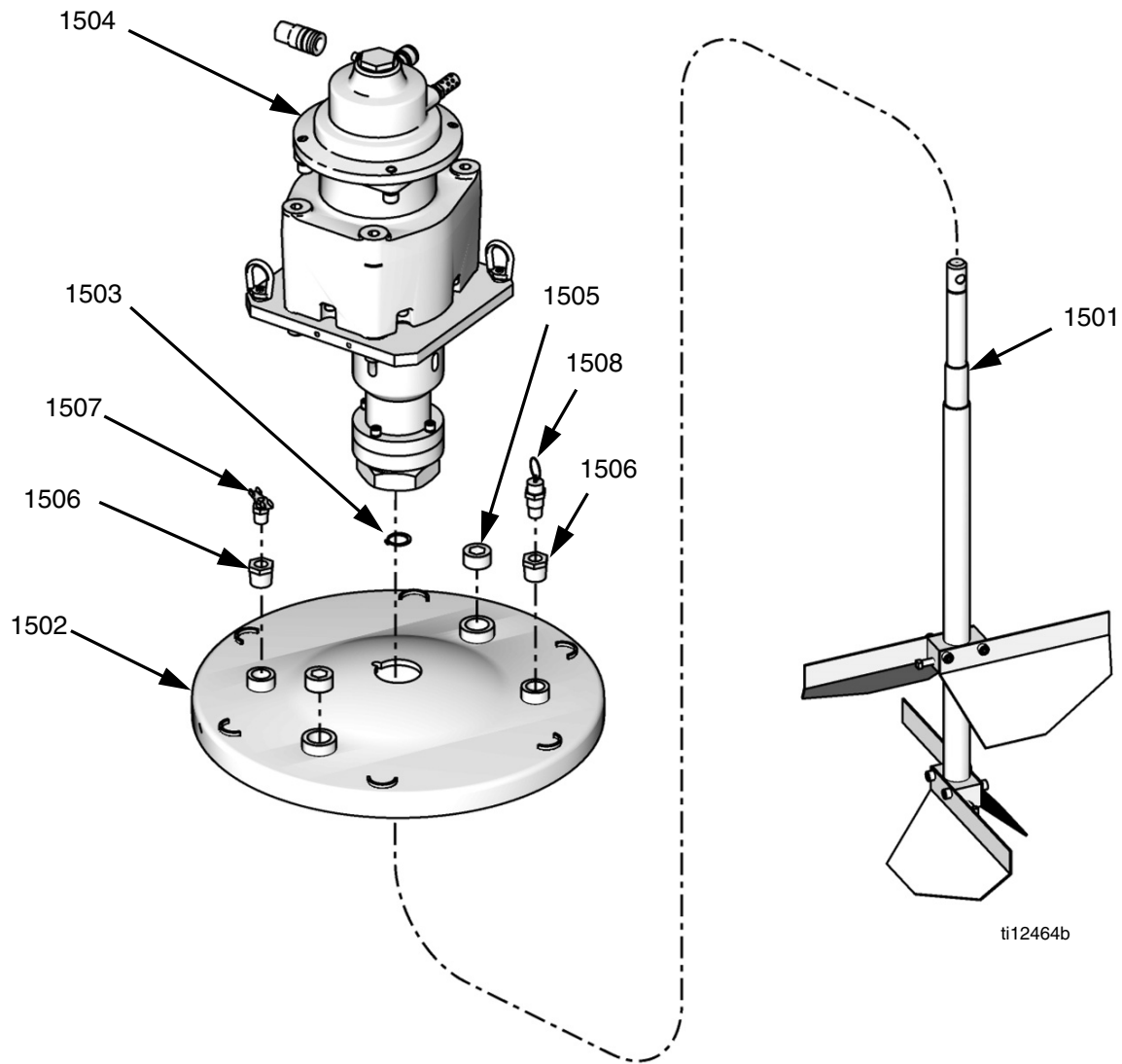

 Apply thread sealant tape to male npt threads prior to installation.

Ref	Part	Description	Quantity			
			30 L Lid Assembly	30 L Lid Assembly with De-gas	30 L Lid Assembly with Pneumatic Agitator	60 L Lid Assembly with Pneumatic Agitator
1501	257607	BLADE, assy, agitator			1	
	257608	BLADE, assy, agitator				1
1502	---	LID			1	1
	---	LID	1	1		
1503	122776	RING, retaining, external, 0.750, mild steel			1	1
1504◆	24J183	AGITATOR			1	1
1505	187875	GAUGE, pressure, fluid		1		
	15M861	FITTING, 3/4 npt x 1/4 npt		1		
	111384	PLUG, pipe	2		2	2
1506	122767	BUSHING, 1/2 x 1/4 npt, male/female, stainless steel, 6K, 316	2	2	2	2
1507	94/0736/96	VALVE, drain cock, 1/4 npt, male, brass	1	1	1	1
1508	15R145	VALVE, relief, 1/4 npt, male, 40 psi, sil	1	1	1	1
1509	† 255746	FITTING, vacuum tree		1		

† Part not shown.

◆ Previous versions of these lid assemblies include agitator 255670 but that agitator is no longer available. Agitator kit 24J182 is the replacement for 255670.

Lid Assemblies Electric Agitator

CAUTION

The electric agitators used with off-board tanks will fail prematurely when material viscosity exceeds 48,000 cps. Use pneumatic agitators if material viscosity exceeds 48,000 cps.

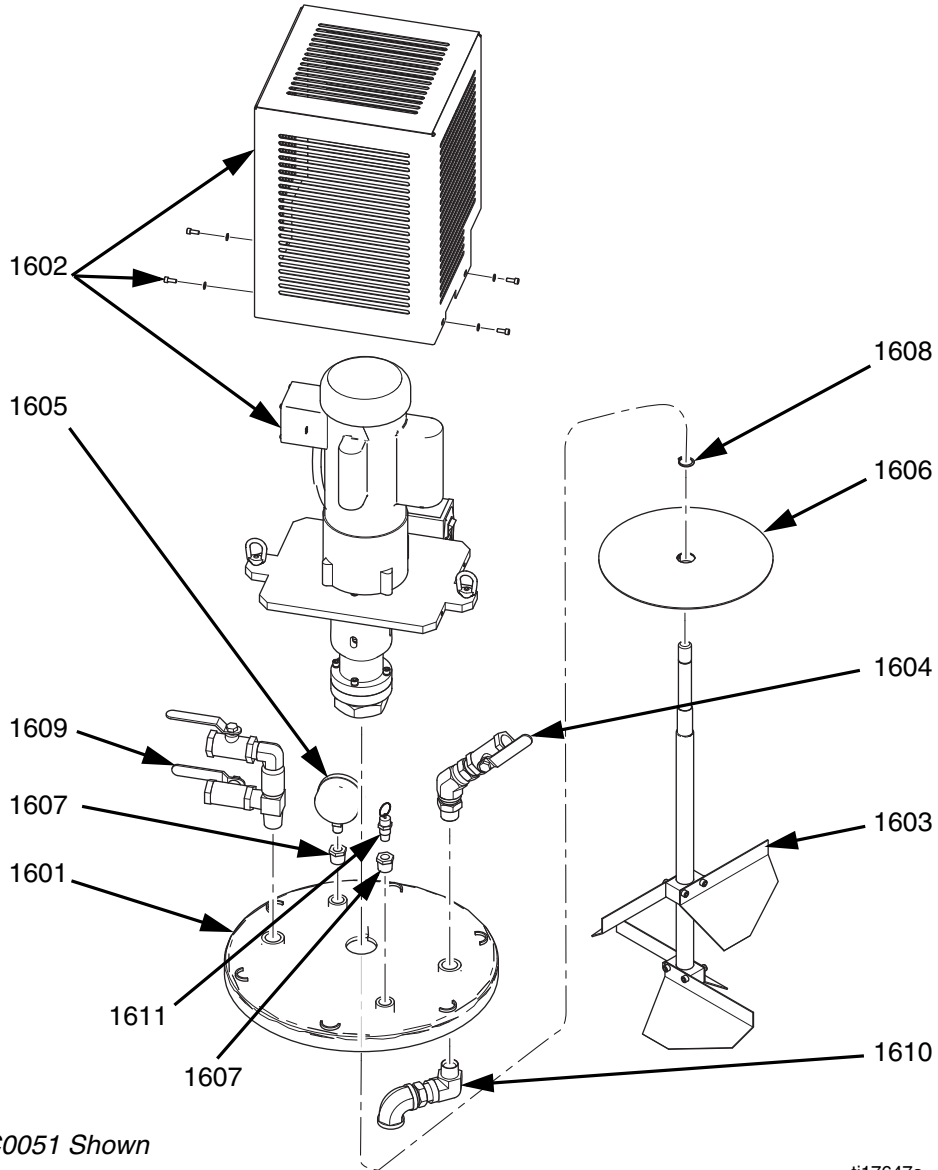

ti17647a

 Apply thread sealant tape to male npt threads prior to installation.

Ref	Part	Description	Quantity			
			LID, assy, 7.5 gal, agit	LID, assy, 15 gal, agit	LID, assy, 7.5 gal, agit, vac, fill	LID, assy, 15 gal, agit, vac, fill
1601	---	LID, agitator	1	1	1	1
1602	256822	MOTOR, assy, single phase, 50/60hz	1	1	1	1
1603	257608	BLADE, assy agitator, 75l		1		1
	257607	BLADE, assy, agitator, 38l	1		1	
1604	257602	VALVE, assy, ball, fill, lid, 3/4, ss			1	1
	125009	PLUG, pipe	2	2		
1605	124400	GAUGE, pressure			1	1
	94/0736/96	VALVE, drain cock, 1/4npt, m, brs	1	1		
1606	257606	PLATE, slinger, 38l/75l			1	1
1607	122767	BUSHING, 1/2x1/4npt, mf, ss, 6k, 316	2	2	2	2
1608	122776	RING, ret, ext, 0.750, ms	1	1	1	1
1609	257746	FITTING, vacuum tree assy			1	1
1610	257747	FITTING, inner fill port assy			1	1
1611	15R145	VALVE, relief, 1/4npt, m, 40psi, sil	1	1	1	1
1612	U90331	TAPE, PTFE 1/2" wide	1	1	1	1
1613	070408	SEALANT, pipe	1	1		
1614	070445	SEALANT, thread	1	1		

Vacuum Tree Manifold, 255342

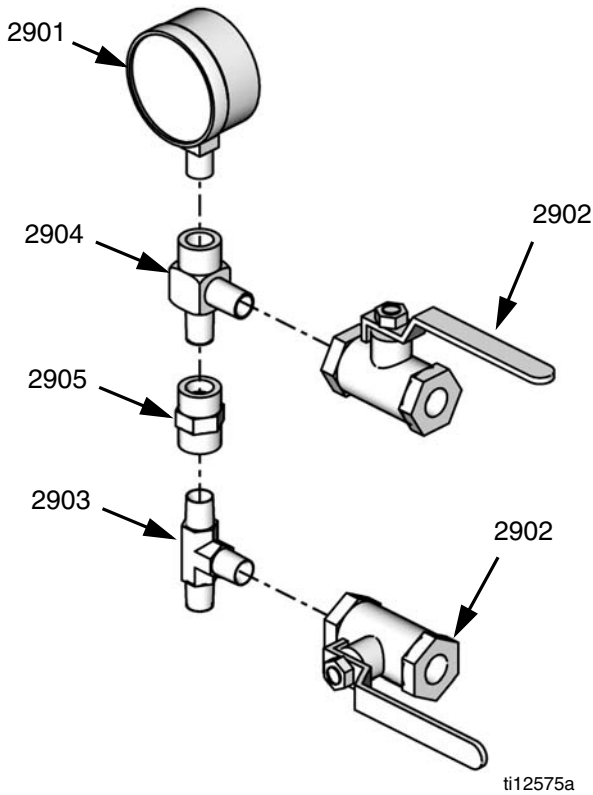

⚠ Apply thread sealant tape to male npt threads prior to installation.

Ref	Part	Description	Qty
2901	82/0220-1/11	GAUGE, 30 in. hg, 30 psi, liquid filled	1
2902	94/0900-R2/99	VALVE, ball, 2-way, 1/4 npt, female, 2K, mild steel	2
2903	121087	FITTING, tee, male-male-male, 1/4 in. NPT	1
2904	121088	FITTING, tee, male-male-female, 1/4 in. npt	1
2905	121089	FITTING, nipple, hex, female-female, 1/4 in. npt	1

Vacuum Tree Manifold, 257746

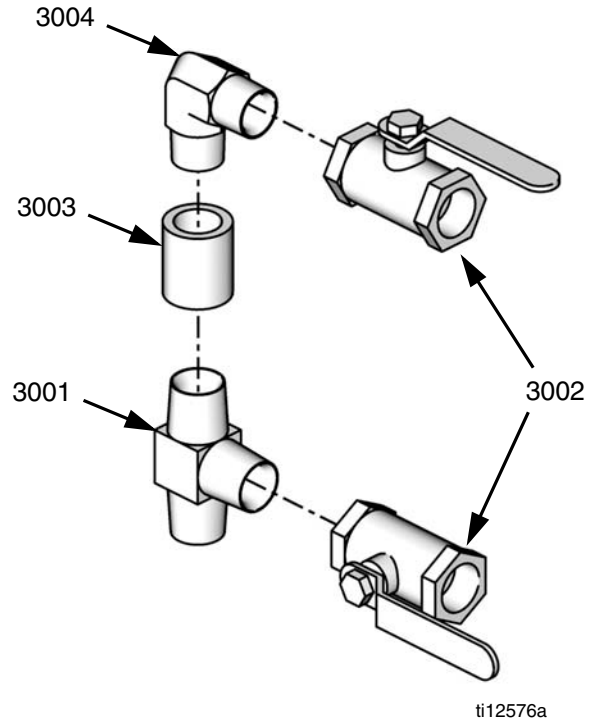

Ref	Part	Description	Qty
3001	1228444	FITTING, tee, 3/4 npt, male, 3k	1
3002	122770	VALVE, ball, 3/4 npt, female	2
3003	122769	COUPLING, 3/4 npt	1
3004	121116	FITTING, elbow, 3/4 npt, male/male, right angle	1

Stainless Steel Tank Agitators

Electric Agitator Motor Assembly, 256822

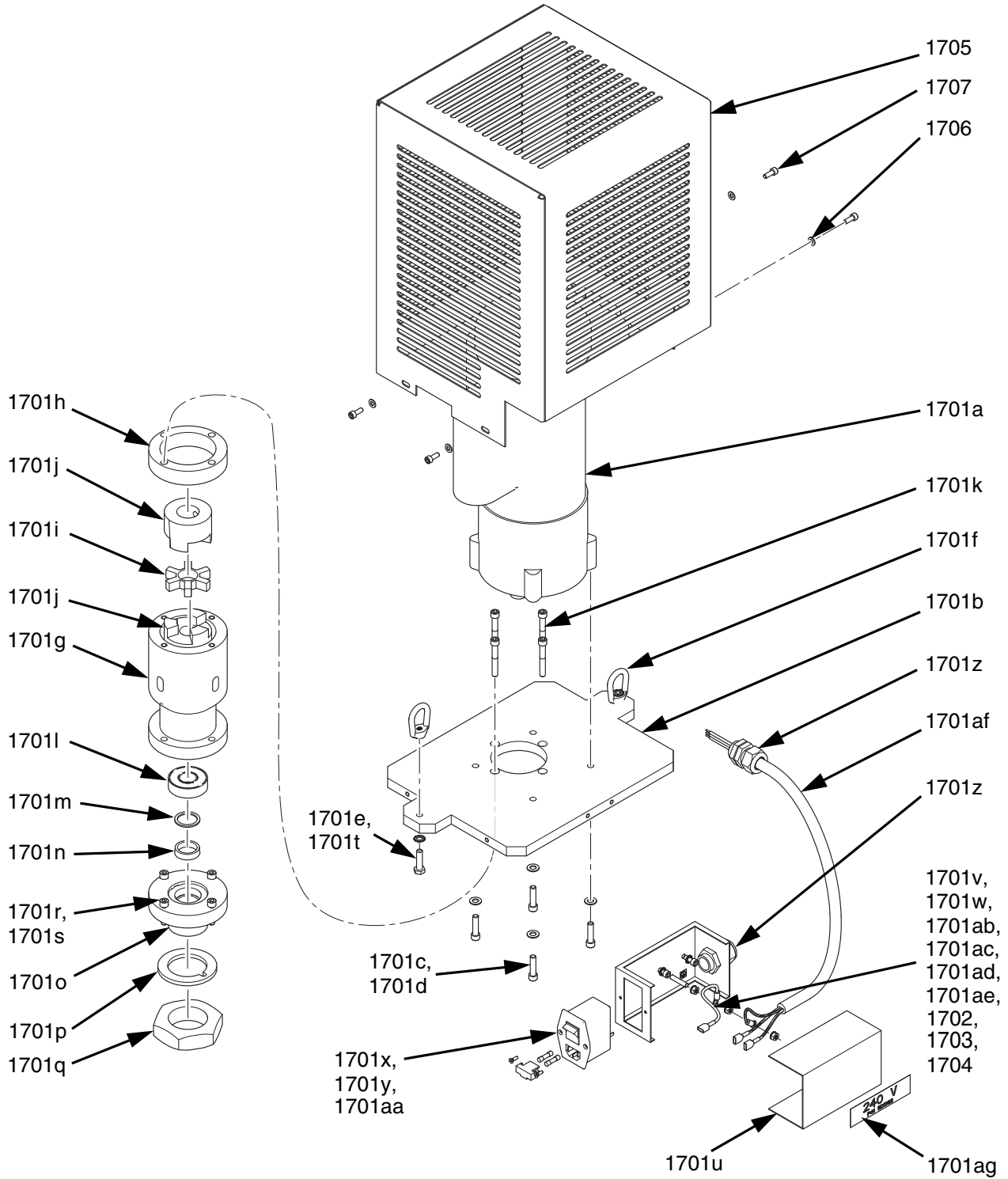

ti17646a

Ref	Part	Description	Qty	Ref	Part	Description	Qty
1701	257605	HOUSING, agitator	1	. 1701r	105510	WASHER, lock	4
. 1701a	124741	MOTOR, agitator	1	. 1701s	112222	SCREW, cap	4
. 1701b	16K267	ADAPTER, plate, agitator motor	1	. 1701t	100985	WASHER, lock	2
. 1701c	158223	WASHER	4	. 1701u	15R328	JUNCTION BOX, motor switch	1
. 1701d	108803	SCREW, hex	4	. 1701v	111307	WASHER, lock	2
. 1701e	100021	SCREW, cap	2	. 1701w	102598	SCREW, cap	2
. 1701f	122775	NUT, eye, 1/4-20	2	. 1701x	120910	SOCKET, electrical	1
. 1701g	15Y358	HOUSING, upper, agitator	1	. 1701y	120916	SCREW	2
. 1701h	15V746	SPACER, agitator	1	. 1701z	121172	GRIP, cord	2
. 1701i	122760	COUPLING, alignment	1	. 1701aa	115142	FUSE, 5.0 amp, time lag	2
. 1701j	122761	HOSE, alignment	2	. 1701ab▲	125008	LABEL, earth ground	1
. 1701k	101885	SCREW, cap	4	. 1701ac	121013	SCREW, socket head	1
. 1701l	122774	BEARING, ball	2	. 1701ad	120993	NUT, hex	3
. 1701m	15Y360	SPACER, seal, shaft	1	. 1701ae	24H375	HARNESS, ground	1
. 1701n	122772	SEAL	1	. 1701af	24H376	HARNESS, power	1
. 1701o	15Y357	HOUSING, lower	1	.1701ag▲	15X092	LABEL, 240 volts	1
. 1701p	15Y363	GASKET	1	1702	124442	TERMINAL, ring	1
. 1701q	15Y355	NUT, shaft	1	1703	124437	CAP, splice	4
				1704	124436	CONNECTOR, splice	4
				1705	24K356	COVER, motor	1
				1706	116876	WASHER	4
				1707	102598	SCREW, cap	4

▲ Replacement Danger and Warning labels, tags, and cards are available at no cost.

Electric Agitator Motor, Assemblies 255337 and 255338

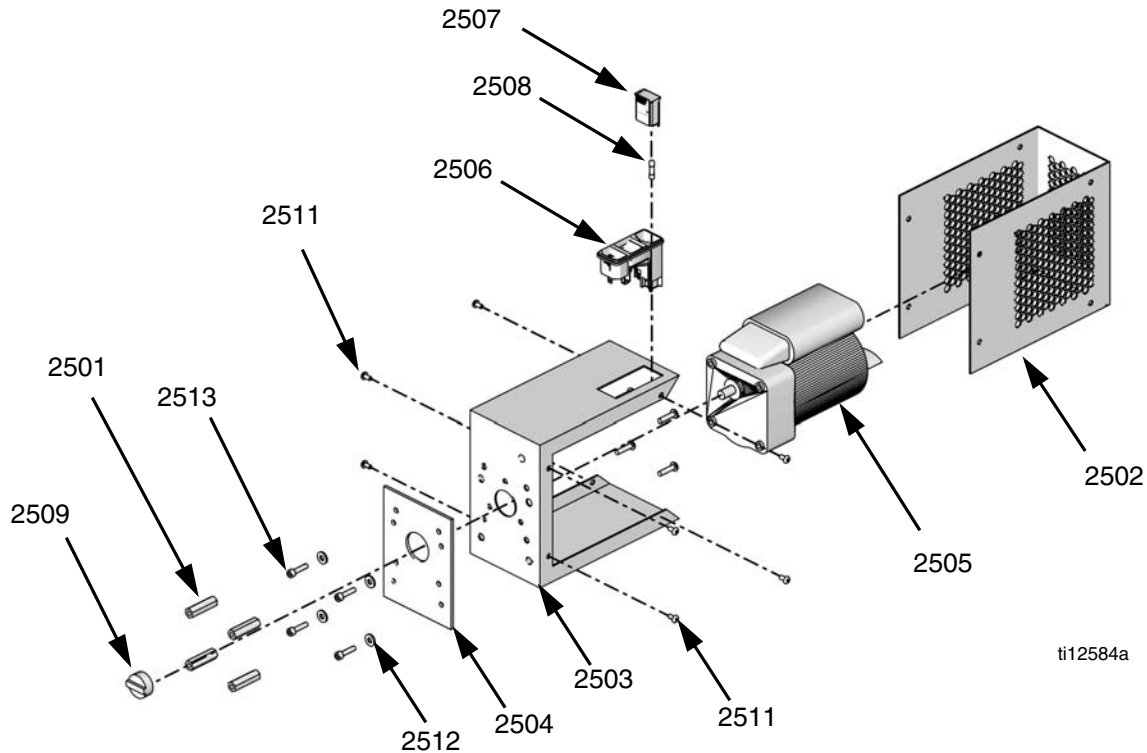

ti12584a

Assembly 255337 Shown

Ref	Part	Description	Qty
2501	01/1198-2/97	FASTENER, standoff, agitator, hd, elec, alu	4
2502	01/2218/97	ENCLOSURE, agitator, electric, prm/f, hd	1
2504	01/2219/97	PLATE, adapter, electric agitator, hd, prm	1
2505	81/2218-1/11	MOTOR, 50 rpm, 60 in-lb, 120V, 1.2A (assembly 255337 only)	1
	256613	MOTOR, assembly, 50 rpm, 60 in-lb, 230V (assembly 255338 only)	1
2506	81/1040/11	MODULE, AC, 2P, 250V, 10A, double pull single throw, with fuse	1
2507	81/1040-1/11	MODULE, AC conn, 2p, 250V, 10A, with bar	1
2508	81/1053-1.6/11	FUSE, 5 x 20 mm, 1.6A, time delay	1
2509	84/2215-A/11	COUPLING, alignment, 1 in. OD, HUB, 3/8 in. ID	1
2510	96/0212/99	FASTENER, button head cap screw, 10-24 x 0.50, mild steel	4
2511	96/0271/99	FASTENER, button head cap screw, 8-32 x 0.31, mild steel	8
2512	120907	WASHER, plain #10	4
2513	120961	SCREW, button head cap screw, 10-32 x 1.25 in., stainless steel	4
2514	† 121599	CORD, power, v-lock, C14/C13, 10A	1

† Part not shown.

Pneumatic Agitator Motor Assembly, 02/1116/50

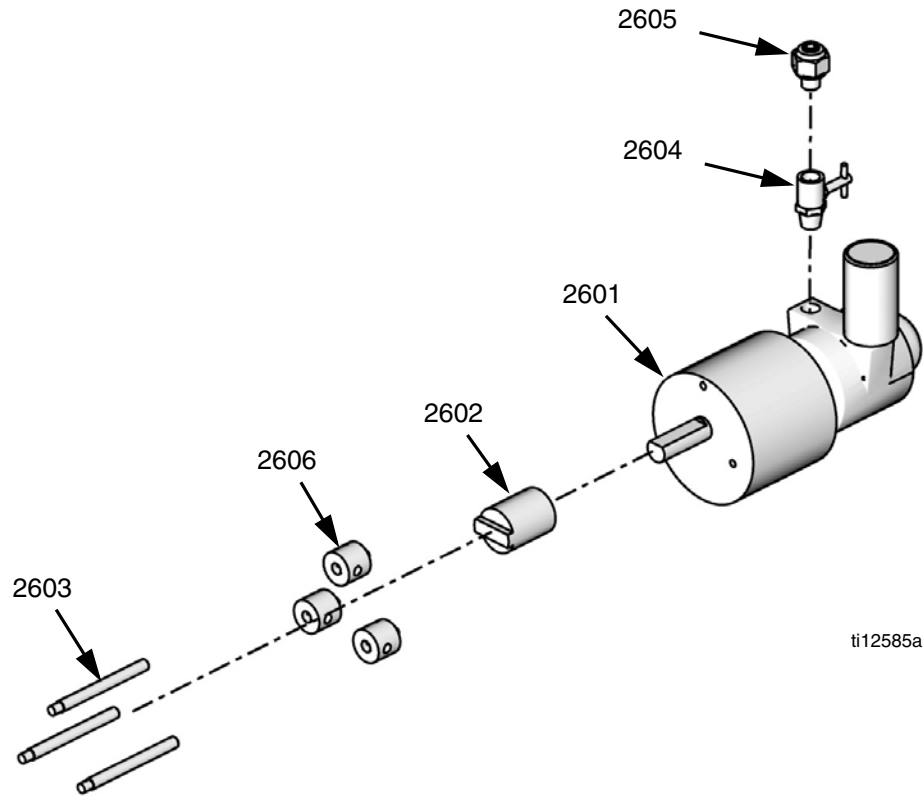

ti12585a

Ref	Part	Description	Qty
2601	82/0216/11	MOTOR, pneumatic, agitator, 0.32 hp	1
2602	01/1189/98	ADAPTER, coupling, air motor, agitator	1
2603	01/1168/98	SHAFT, mount, pneumatic gear, agitator, stainless steel	3
2604	94/0838/96	VALVE, needle, 1/8 npt x 1/8 npt, male/female	1
2605	94/0702/96	FITTING, 1/4 tube x 1/8 npt, male, brass	1
2606	01/1179/98	ADAPTER, shaft, mounting, air motor	3

Pneumatic Agitator Motor, 255670

NOTE: This agitator assembly is no longer available. Piece parts from the assembly can be ordered but if the entire assembly is needed then agitator kit 24J182 must be ordered.

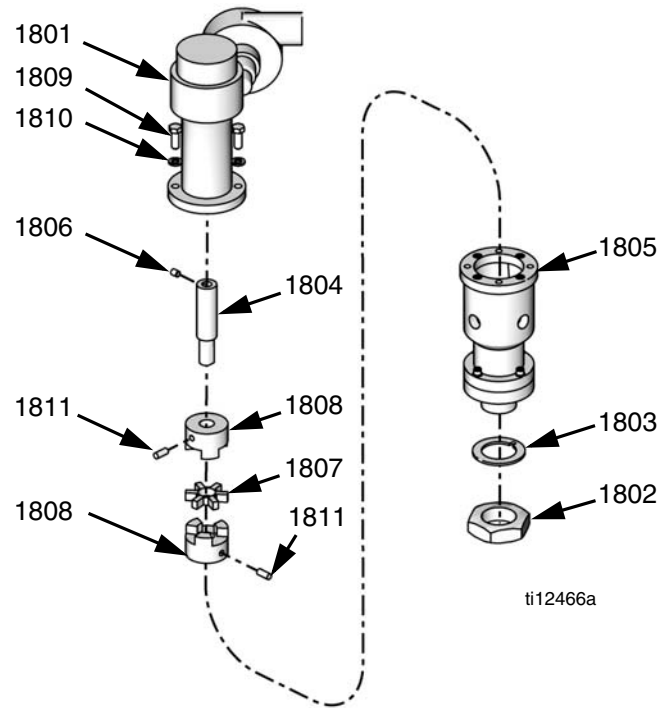

Pneumatic Agitator Motor, 24J183

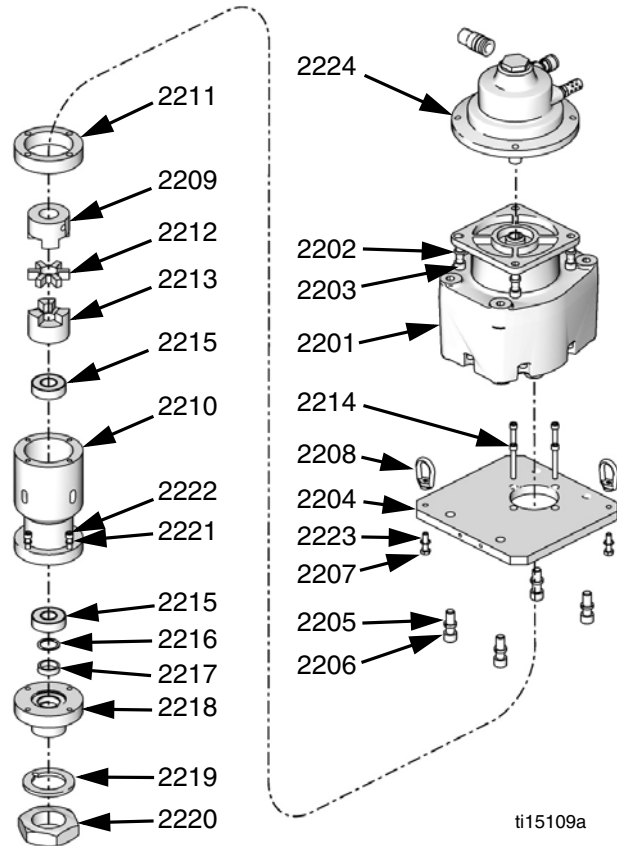

Ref	Part	Description	Qty
1801	---	MOTOR, pneumatic, agitator, 0.5 hp, 15:1	1
1802	15Y355	NUT, agitator, 1.75-16, 7/8 shaft	1
1803	01/1487/01	GASKET, mating, agitator housing, asme, buna	1
1804	01/1492/98	SHAFT, extension, air motor coupler	1
1805	15Y358	HOUSING, agitator, pneumatic	1
1806	5-06-0706	SCREW, shs, 5/16-18 x 0.38, cup point	1
1807	84/1480/11	COUPLING, alignment, 2.11 OD, disk, TPE	1
1808	84/1481/11	COUPLING, alignment, 2.11 in. OD, hub, 3/4 ID	2
1809	96/0038/99	SCREW, hex head cap, 3/8-16 x 1.00, mild steel, grade 5	2
1810	96/0046/99	WASHER, lock, split, 3/8, mild steel	2
1811	96/0455-1/99	SCREW, socket head cap, 5/16-18 x 0.75, cup point	2

--- Not available for sale.

Ref	Part	Description	Qty
2201	121953	GEAR REDUCER, 56c, 27.8 ratio, 2 stage	1
2202	106115	WASHER, lock, hi-collar	4
2203	C19837	SCREW, cap, socket head	4
2204	15V745	ADAPTER, plate, agitator motor	1
2205	112600	WASHER, lock, spring, hi-collar	4
2206	125012	SCREW, socket head, 7/16-14 x 1.25	4
2207	100021	SCREW, hex head cap	2
2208	122775	NUT, eye, 1/4-20, mild steel	2
2209	121963	COUPLER, agitator motor, 1 in.	1
2210	15Y358	HOUSING, upper, agitator, electric	1
2211	15V746	SPACER, agitator motor	1
2212	122760	COUPLING, alignment, disk, TPE	1
2213	122761	HOSE, alignment, hub	1
2214	101885	SCREW, cap, sch	4
2215	122774	BEARING, ball, 3/4 bore x 1-3/4 dia. x 1/2	2
2216	15Y360	SPACER, seal, shaft, agitator	1
2217	122772	SEAL, 0.875 x 1.125, ptfе	1
2218	15Y357	HOUSING, lower, agitator, electric	1
2219	15Y363	GASKET, mating, agitator housing	1
2220	15Y355	NUT, agitator, shaft, 1.75-16	1
2221	105510	WASHER, lock, spring hi-collar	4
2222	112222	SCREW, cap, sch	4
2223	100985	WASHER, lock	2
2224	24J181	MOTOR, air	1
2225	070269	SEALANT, anaerobic	1

Agitator Blade Assemblies 257607 and 257608

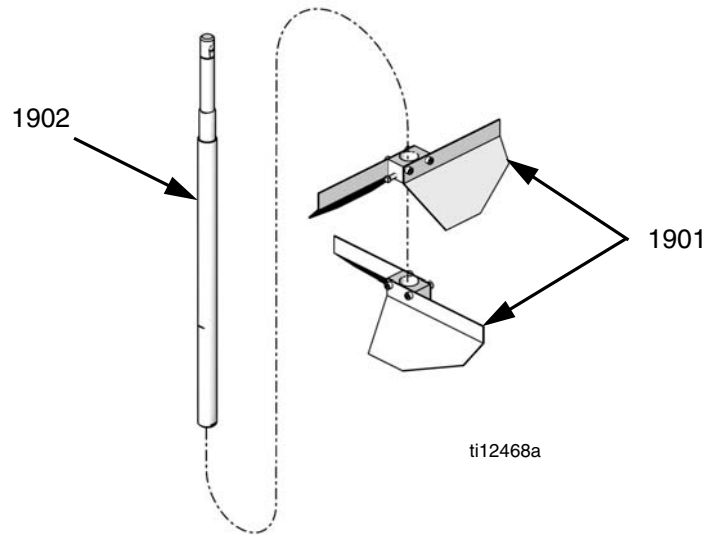

Assembly 257607 Shown

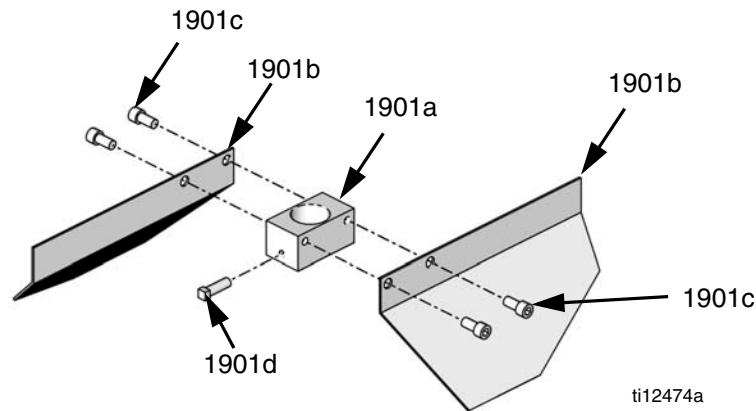

Ref	Part	Description	Qty
1901	257604	BLADE, assy, electric agitator	2
1901a	15Y362	BLOCK, blade, coupler, 1 in. diameter	1
1901b	15Y361	BLADE, agitator	2
1901c	551903	FASTENER, socket head cap screw, 1/4-20 x 0.50, stainless steel	4
1901d	122778	FASTENER, square head, 1/4-20 x 0.75, stainless steel	1
1902	15M624	SHAFT, blade assy (assembly 257607 only)	1
	15M625	SHAFT, blade assy (assembly 257608 only)	1

Level Sensors

Polyethylene Tanks Level Sensors, Assembly LC0278

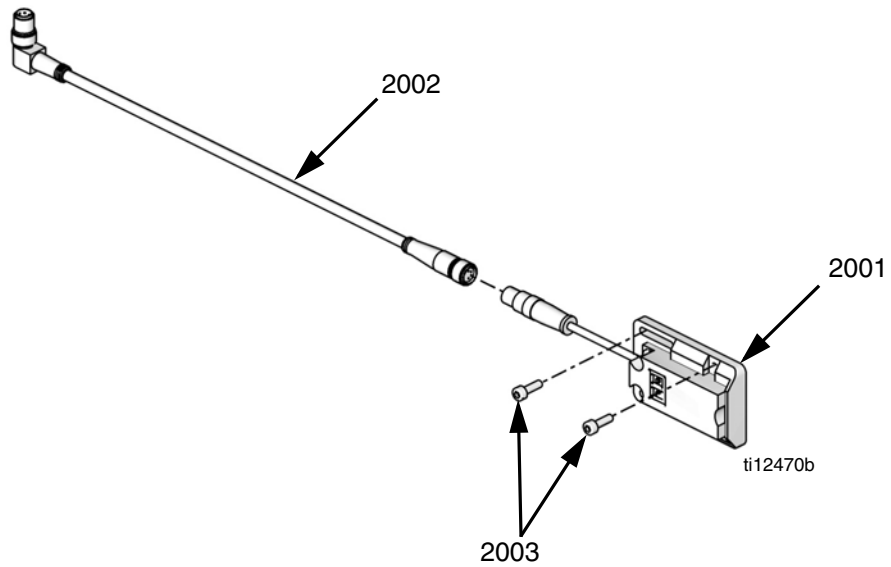

Ref	Part	Description	Qty
2001	123549	SENSOR, level, quick disconnect	2
2002	121686	CABLE, M8 x M8, 4P, female / male, straight/right angle, 2 m	2
2003	96/1000/99	FASTENER, screw, socket head cap, M3 x 8, mild steel	4

Stainless Steel Tanks Level Sensors

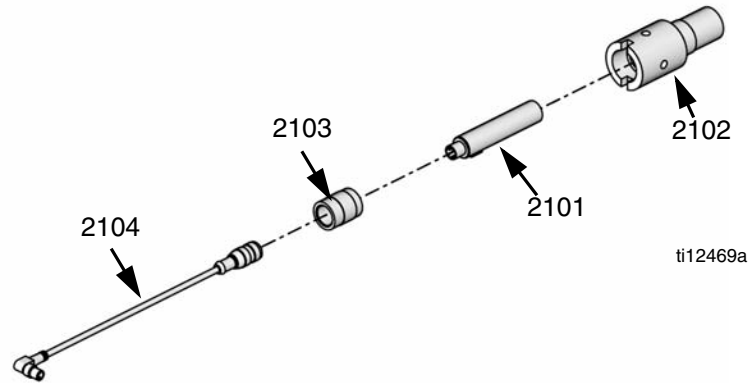

Sensor Package	Description	Reference Number, Description, Quantity				
		2101	2102	2103	2104	
		121511 Level Sensor	01/0025-EF/87 Level Sensor Well	15U978 Sensor Well Cap	121684 CABLE, 2 m	121694 CABLE, 3 m
LC0279	Low level sensor for two 7.5 L tanks	2	2	2	2	
LC0280	Low level sensor for one 7.5 L tank	1	1	1	1	
LC0281	Low level sensor for one 7.5 L tank and one low level sensor for one 30 L or 60 L tank	2	2	2	1	1
LC0282	Low level sensor for two 30 or 60 L tanks	2	2	2		2
LC0283	Low level sensor for one 30 or 60 L tank	1	1	1		1
LC0284	High and low level sensors for two 7.5 L tanks	4	4	4	4	
LC0285	High and low level sensors for one 7.5 L tank	2	2	2	2	
LC0286	High and low level sensors for one 30 or 60 L, Low level sensors for one 7.5 L tank	3	3	3	1	2
LC0287	High and low level sensors for two 30 or 60 L tanks	4	4	4		4
LC0288	High and low level sensors for one 30 or 60 L tank	2	2	2		2
LC0289	High and low level sensors for one 30 or 60 L tank, high and low level sensors for one 7.5 L tank	4	4	4	2	2

Kits

Mixer and Shroud Options

Part	Description
LC0063	Mixer, 3/16 in. (6.5 mm) x 32, 10 Mixers with shroud
LC0057	Mixer, 1/4 in. (6.5 mm) x 24, 10 Mixers with shroud
LC0058	Mixer, 3/8 in. (9.8 mm) x 24, 10 Mixers with shroud
LC0059	Mixer, 3/8 in. (9.8 mm) x 36, 10 Mixers with shroud
LC0060	Mixer, 3/8 in. (9.8 mm) Combo, 10 Mixers with shroud
LC0061	Mixer, 3/16 in. (4.8 mm) x 32 Luer Lock, 10 Mixers with shroud
LC0062	Mixer, 1/4 in. (6.5 mm) x 24 Luer Lock, 10 Mixers with shroud
LC0077	Mixer, 3/16 in. (4.8 mm) x 32, 50 Mixers
LC0078	Mixer, 1/4 in. (6.5 mm) x 24, 50 Mixers
LC0079	Mixer, 3/8 in. (9.8 mm) x 24, 50 Mixers
LC0080	Mixer, 3/8 in. (9.8 mm) x 36, 50 Mixers
LC0081	Mixer, 3/8 in. (9.8 mm) combo, 50 Mixers
LC0083	Mixer, 1/4 in. (6.5 mm) x 24 Luer Lock, 50 Mixers
LC0082	Mixer, 3/16 in. (4.8 mm) x 32 Luer Lock, 50 Mixers
LC0084	Mixer, 3/16 in. (4.8 mm) x 32, 250 Mixers
LC0085	Mixer, 1/4 in. (6.5 mm) x 24, 250 Mixers
LC0086	Mixer, 3/8 in. (9.8 mm) x 24, 250 Mixers
LC0087	Mixer, 3/8 in. (9.8 mm) x 36, 250 Mixers
LC0088	Mixer, 3/8 in. (9.8 mm) combo, 250 Mixers
LC0089	Mixer, 3/16 in. (4.8 mm) x 32 Luer Lock, 250 Mixers
LC0090	Mixer, 1/4 in. (6.5 mm) x 24 Luer Lock, 250 Mixers

MD2 Valve Kits

 See MD2 Dispense Valve instruction manual referenced at the beginning of this manual for installation instructions or for more information.

Part	Description
255217	MD2, kit rebuild, air cylinder
255218	MD2, kit rebuild, back-end of wet section (no needle or seat)
255219	MD2, Soft Seat rebuild, needle and nose
255220	MD2, convert Soft Seat nose to Hard Seat (Hard Seat rebuild), needle and nose

Machine Rebuild Kits

 See the PR70 and PR70v Repair - Parts manual referenced at the beginning of this manual for parts included in each kit.

Part	Description
LC0091	3.0 in. Air Cylinder rebuild kit
LC0092	4.5 in. Air Cylinder rebuild kit
LC0093	Check Valve rebuild kit, Stainless Steel Ball
LC0318	Check Valve rebuild kit, Carbide Ball
LC0094	Rear Pump Seal rebuild kit

Tank Accessories

Part	Description
LC0097	Desiccant Dryer, 3/8 in. NPT with adapter and cartridge
LC0098	Desiccant Dryer refill cartridge
◆LC0095	Nitrogen Harness Kit for 30 L and 60 L tank, 1 tank
◆LC0096	Nitrogen Harness Kit for 30 L and 60 L tank, 2 tanks
†LC0099	Vacuum Transfer Pump, 120V, down to 25 Torr
†LC0100	Vacuum Transfer Pump, 240V, down to 25 Torr
‡26A300	Ball Valve Kit, pr70, tanks

† Item includes only the pump. A vacuum kit must be purchased to install the pump onto the tank.

◆ Kit includes all parts needed to connect a nitrogen tank to the material tank.

‡ Kit includes parts needed to add a ball valve to the PR70.

Vacuum Kits

These vacuum kits contain the parts necessary to attach a vacuum pump to the tanks.

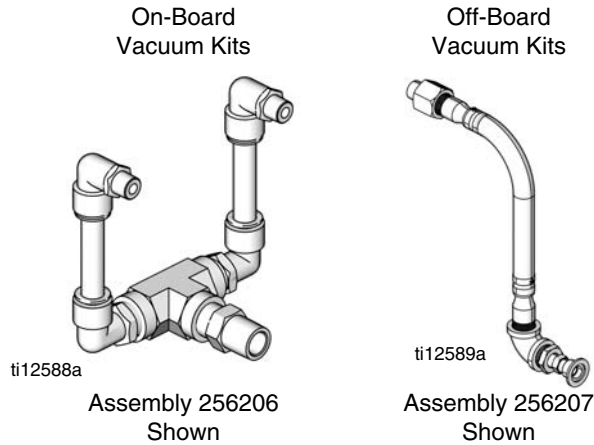

Part	Description
256205	Vacuum Kit, Single On-Board Tank
256206	Vacuum Kit, Two On-Board Tanks
256207	Vacuum Kit, Single Off-Board Tank
256209	Vacuum Kit, Two Off-Board Tanks

Refill Kits

Refill Kits 256659 and 256660 are designed to turn on and off a transfer pump as needed to keep the tanks at the proper fluid level. Tank Refill Kit 256577 is designed to open and close a valve to allow fluid to flow into the tank from an always-on transfer pump. Tank Refill Kit 256577 includes the parts necessary to install on the base or lid of a 7.5 L, 30 L, or 60 L tank.

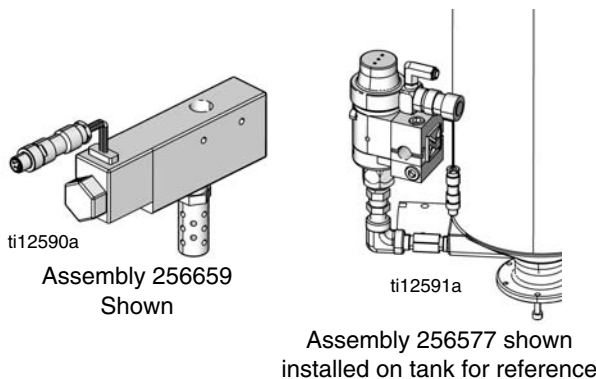

Part	Description
256659	Refill Kit, 1/4 npt, solenoid, 24V
256660	Refill Kit, 1/2 npt, solenoid, 24V
256577	Tank Refill Kit

External Control Interface Connection Kit

Part	Description
LC0008	Cord, I/O interface and splitter

Upgrade Kit, 25B195

This kit upgrades LC0160 and LC0297 models to 25B196 models.

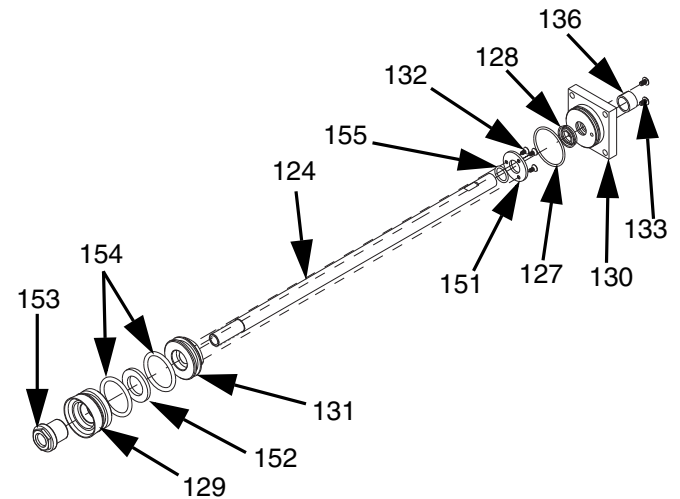

Ref	Part	Description	Qty
124	01/1451/98	TUBE, vent, accumulator, 1.5, stainless steel	1
127	95/0913/00	O-RING, fluoroelastomer	1
128	95/0605/01	SEAL, u-cup, 1/2 ID x 3/4 OD, NIT	1
129	19A695	PISTON, accumulator, PR70	1
130	19A696	CAP, end, accumulator	1
131	19A699	PISTON, backup, accumulator	1
132	130872	FASTENER, fhs	3
133	130873	FASTENER, fbhs, 6-32 x 25, stainless steel	2
136	19A745	BEARING, rulon, accumulator, PR70	1
151	19A698	WASHER, backup, accumulator	1
152	130871	MAGNET, accumulator, PR70	1
153	19A697	INSERT, thread, piston, accumulator	1
154	130870	O-RING, fluoroelastomer	2
155	120775	PACKING, o-ring	1

Dimensions

Machine with On-Board Tanks

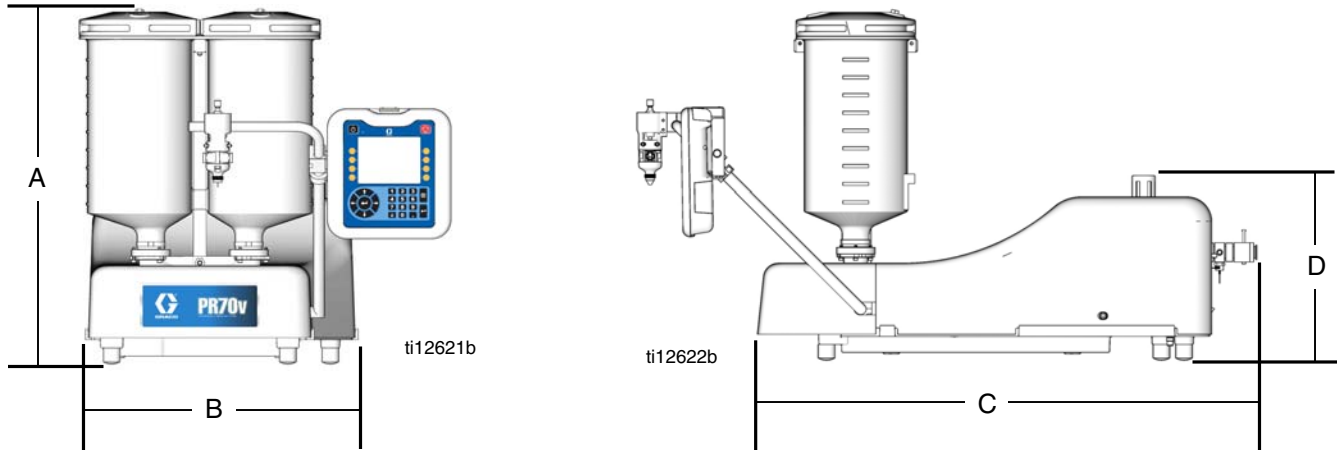

PR70

Ref	† Assembly Dimensions, in. (mm)				
	Polyethylene Tanks		◆ Stainless Steel Tanks		
	No Agitators	With Agitators	3 L	7.5 L, No Agitators	7.5 L, with Agitators
A	26.4 (670)	38.6 (980)	28.2 (716)	38.2 (970)	39.9 (1013)
B	18.5 (470)	18.5 (470)	15.5 (394)	15.5 (394)	15.5 (394)
C	30.6 (778)	30.6 (778)	30.6 (778)	30.6 (778)	30.6 (778)
D	13.4 (340)	13.4 (340)	13.4 (340)	13.4 (340)	13.4 (340)

PR70v

Ref	† Assembly Dimensions, in. (mm)				
	Polyethylene Tanks		◆ Stainless Steel Tanks		
	No Agitators	With Agitators	3 L, No Agitators	7.5 L, No Agitators	7.5 L, with Agitators
A	30.0 (762)	39.4 (1001)	29.0 (737)	39.0 (991)	40.6 (1031)
B	20.9 (531)	20.9 (531)	20.9 (531)	20.9 (531)	20.9 (531)
C	38.6 (980)	38.6 (980)	38.6 (980)	38.6 (980)	38.6 (980)
D	14.3 (363)	14.3 (363)	14.3 (363)	14.3 (363)	14.3 (363)

† Assembly dimensions listed are maximum for all assemblies under the given title.

◆ On-board stainless steel tank dimensions include ball valves and vacuum de-gas in maximum height calculation.

Machine with Off-Board Tanks

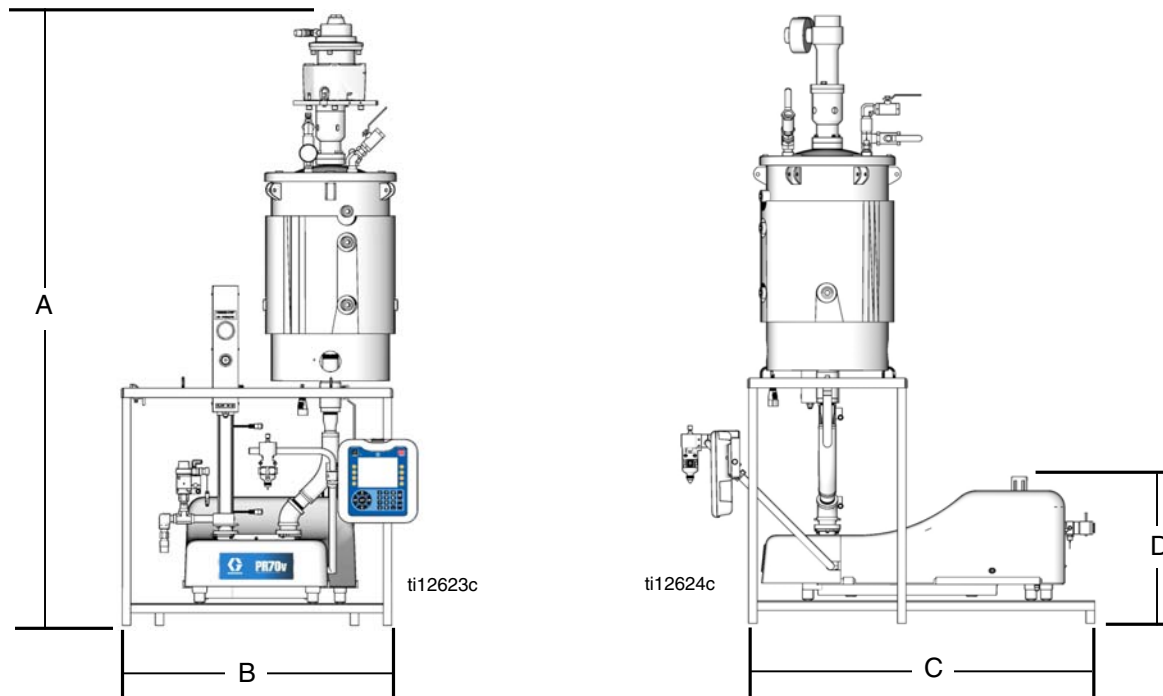

PR70

Ref	† Assembly Dimensions, in. (mm)			
	30 L Tank		60 L Tank	
	No Agitators	With Agitators	No Agitators	With Agitators
A	55.7 (1415)	83.4 (2118)	64.9 (1648)	89.5 (2273)
B	32.1 (815)	32.1 (815)	32.1 (815)	32.1 (815)
C	29.3 (236)	29.3 (236)	29.3 (236)	29.3 (236)
D	16.0 (406)	16.0 (406)	16.0 (406)	16.0 (406)

PR70v

Ref	† Assembly Dimensions, in. (mm)			
	30 L Tank		60 L Tank	
	No Agitators	With Agitators	No Agitators	With Agitators
A	55.7 (1415)	83.4 (2118)	64.9 (1648)	89.5 (2273)
B	32.1 (815)	32.1 (815)	32.1 (815)	32.1 (815)
C	40.1 (1019)	40.1 (1019)	40.1 (1019)	40.1 (1019)
D	17.0 (432)	17.0 (432)	17.0 (432)	17.0 (432)

† Assembly dimensions listed are maximum for all assemblies under the given title.

Technical Data

Metering Pump Effective Area	80 to 960 mm ² (0.124 to 1.49 in. ²) per side
Small Air Cylinder Effective Area	4560 mm ² (7.07 in. ²)
Large Air Cylinder Effective Area	10260 mm ² (15.9 in. ²)
Maximum Stroke Length	38.1 mm (1.50 in.)
Minimum Stroke Length	5.8 mm (0.23 in.)
Volume per Cycle	2 to 70 cc (0.12 to 4.3 in. ³)
Pump Cycles per 1 L (0.26 gal)	14.3 to 500 cycles (varies by piston size)
Ratios (fixed)	1:1 to 12:1 (depending upon cylinders selected)
Maximum Fluid Working Pressure	3000 psi (20.7 MPa, 207 bar)
Maximum Air Input Pressure	100 psi (0.7 MPa, 7 bar)
Maximum Cycle Rate	30 cpm
Maximum Operating Temperature	70°C (160°F), nylon pistons 50°C (120°F) UHMWPE pistons or PE Tanks
Air Inlet Size	1/4 NPT female
Pump Fluid Outlet Size	-03, -04, -06, -08 or -12 JIC fittings for 3/16 in. (4.8 mm), 1/4 in. (6.4 mm), 3/8 in. (9.5 mm), 1/2 in. (12.7 mm), 3/4 in. (19.1 mm) hoses
Wetted Parts	303/304, 17-4 PH, hard chrome, Chromex™, carbide, Chemical Resistant O-rings, PTFE, nylon, UHMWPE
Weight	55 kg (120 lb) typical with two 7.5 L tanks 150 kg (330 lb) typical with two 60 L tanks
Sound Pressure Level (at typical operator station for machine mounted Dispense Valve)	82 dBA
Compressed Air	Less than 10 scfm typical (varies with cycle times)
Electrical Power	<ul style="list-style-type: none"> 100-240 V 50/60Hz, 1 phase for machine – 80 Watts 208-240V 50/60Hz, 1 phase for heat – 11 kW max 120 or 240 VAC 50/60Hz 1 phase for on-board agitators, 80 Watts 240 VAC 50/60Hz 1 phase for off-board agitators, 600 Watts

Graco Standard Warranty

Graco warrants all equipment referenced in this document which is manufactured by Graco and bearing its name to be free from defects in material and workmanship on the date of sale to the original purchaser for use. With the exception of any special, extended, or limited warranty published by Graco, Graco will, for a period of twelve months from the date of sale, repair or replace any part of the equipment determined by Graco to be defective. This warranty applies only when the equipment is installed, operated and maintained in accordance with Graco's written recommendations.

This warranty does not cover, and Graco shall not be liable for general wear and tear, or any malfunction, damage or wear caused by faulty installation, misapplication, abrasion, corrosion, inadequate or improper maintenance, negligence, accident, tampering, or substitution of non-Graco component parts. Nor shall Graco be liable for malfunction, damage or wear caused by the incompatibility of Graco equipment with structures, accessories, equipment or materials not supplied by Graco, or the improper design, manufacture, installation, operation or maintenance of structures, accessories, equipment or materials not supplied by Graco.

This warranty is conditioned upon the prepaid return of the equipment claimed to be defective to an authorized Graco distributor for verification of the claimed defect. If the claimed defect is verified, Graco will repair or replace free of charge any defective parts. The equipment will be returned to the original purchaser transportation prepaid. If inspection of the equipment does not disclose any defect in material or workmanship, repairs will be made at a reasonable charge, which charges may include the costs of parts, labor, and transportation.

THIS WARRANTY IS EXCLUSIVE, AND IS IN LIEU OF ANY OTHER WARRANTIES, EXPRESS OR IMPLIED, INCLUDING BUT NOT LIMITED TO WARRANTY OF MERCHANTABILITY OR WARRANTY OF FITNESS FOR A PARTICULAR PURPOSE.

Graco's sole obligation and buyer's sole remedy for any breach of warranty shall be as set forth above. The buyer agrees that no other remedy (including, but not limited to, incidental or consequential damages for lost profits, lost sales, injury to person or property, or any other incidental or consequential loss) shall be available. Any action for breach of warranty must be brought within two (2) years of the date of sale.

GRACO MAKES NO WARRANTY, AND DISCLAIMS ALL IMPLIED WARRANTIES OF MERCHANTABILITY AND FITNESS FOR A PARTICULAR PURPOSE, IN CONNECTION WITH ACCESSORIES, EQUIPMENT, MATERIALS OR COMPONENTS SOLD BUT NOT MANUFACTURED BY GRACO. These items sold, but not manufactured by Graco (such as electric motors, switches, hose, etc.), are subject to the warranty, if any, of their manufacturer. Graco will provide purchaser with reasonable assistance in making any claim for breach of these warranties.

In no event will Graco be liable for indirect, incidental, special or consequential damages resulting from Graco supplying equipment hereunder, or the furnishing, performance, or use of any products or other goods sold hereto, whether due to a breach of contract, breach of warranty, the negligence of Graco, or otherwise.

FOR GRACO CANADA CUSTOMERS

The Parties acknowledge that they have required that the present document, as well as all documents, notices and legal proceedings entered into, given or instituted pursuant hereto or relating directly or indirectly hereto, be drawn up in English. Les parties reconnaissent avoir convenu que la rédaction du présente document sera en Anglais, ainsi que tous documents, avis et procédures judiciaires exécutés, donnés ou intentés, à la suite de ou en rapport, directement ou indirectement, avec les procédures concernées.

Graco Information

Sealant and Adhesive Dispensing Equipment

For the latest information about Graco products, visit www.graco.com.

For patent information, see www.graco.com/patents.

TO PLACE AN ORDER, contact your Graco distributor, go to www.graco.com, or call to identify the nearest distributor.

If calling from the USA: 1-800-746-1334

If calling from outside the USA: 0-1-330-966-3000

All written and visual data contained in this document reflects the latest product information available at the time of publication. Graco reserves the right to make changes at any time without notice.

This manual contains English. MM 312394

Graco Headquarters: Minneapolis
International Offices: Belgium, China, Japan, Korea

GRACO INC. AND SUBSIDIARIES • P.O. BOX 1441 • MINNEAPOLIS MN 55440-1441 • USA
Copyright 2007, Graco Inc. All Graco manufacturing locations are registered to ISO 9001.

www.graco.com
Revision ZAG, July 2019