

Xtreme[®] PFP

3A2798L

EN

For use with bulk supply of medium to high viscosity sealants and adhesive materials. For professional use only.



Important Safety Instructions

Read all warnings and instructions in this manual. Save these instructions.

Model 16T311

5 gallon (20 liter), XL6500™ air motor, with cart

7250 psi (50 MPa, 500 bar) Maximum Fluid Working Pressure

100 psi (0.7 kPa, 7 bar) Maximum Air Working Pressure

100 psi (0.7 kPa, 7 bar) Maximum Air Inlet Pressure

Model 16P957

5 gallon (20 liter), XL6500™ air motor, no cart

7250 psi (50 MPa, 500 bar) Maximum Fluid Working Pressure

100 psi (0.7 kPa, 7 bar) Maximum Air Working Pressure

100 psi (0.7 kPa, 7 bar) Maximum Air Inlet Pressure

Model 24X069

5 gallon (20 liter), XL10000™ air motor, with cart

7250 psi (50 MPa, 500 bar) Maximum Fluid Working Pressure

100 psi (0.7 kPa, 7 bar) Maximum Air Working Pressure

100 psi (0.7 kPa, 7 bar) Maximum Air Inlet Pressure

Model 24X068

5 gallon (20 liter), XL10000™ air motor, no cart

7250 psi (50 MPa, 500 bar) Maximum Fluid Working Pressure

100 psi (0.7 kPa, 7 bar) Maximum Air Working Pressure

100 psi (0.7 kPa, 7 bar) Maximum Air Inlet Pressure

Model 24X069 shown

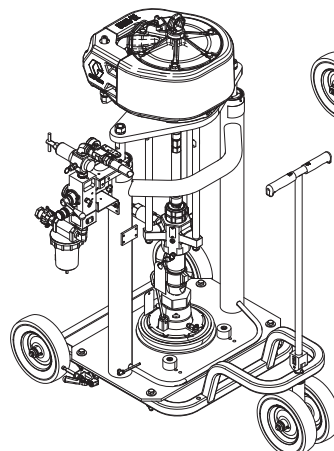
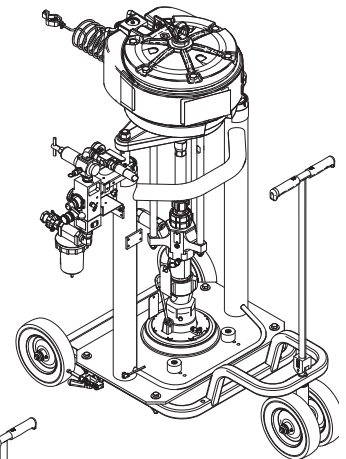

Model 16T311 shown

Contents

Related Manuals	2	Troubleshooting	16
Warnings	3	Repair	17
Component Identification	5	Disconnect Pump from Platen	17
Installation	8	Connect Platen to Pump	17
General Information	8	Remove Wipers	17
Location	8	Install Wipers	17
Grounding	8	Disconnect Displacement Pump	18
Connect Mix Line and Gun	9	Remove Displacement Pump	18
Mechanical Setup	9	Install Displacement Pump	18
Attach Drum Stops	9	Connect Displacement Pump	18
Supply System Operation	10	Remove Air Motor	19
Before Operating	10	Install Air Motor	19
Pressure Relief Procedure	10	Supply Unit Repair	20
Flush Before Using Equipment	10	Parts	22
Start and Adjust Ram	10	Check Valve (16T481)	27
Start and Adjust Pump	11	Accessories	30
Change Drums	11	Static Mixer Kit (16T316)	30
Flush	12	Dimensions	31
Shutdown and Care of the Pump	12	Technical Data	32
Replace Throat Seals	12	Graco Standard Warranty	34
Remove Quick Coupler	12	Graco Information	34
Before Beginning Repair	13		
Maintenance Procedures	13		
Platen Maintenance	13		
Adjust Spacers	13		
Remove and Reinstall Wiper	14		











Related Manuals

The following manuals are available at www.graco.com.
Component Manuals in English:







Manual	Description
311762	Xtreme Lowers Instructions-Parts
3A5423	XL™ 6500 and 3400 Air Motor Instructions-Parts
334644	Xtreme XL Air Motor Instructions-Parts

Warnings

The following warnings are for the setup, use, grounding, maintenance, and repair of this equipment. The exclamation point symbol alerts you to a general warning and the hazard symbols refer to procedure-specific risks. When these symbols appear in the body of this manual or on warning labels, refer back to these Warnings. Product-specific hazard symbols and warnings not covered in this section may appear throughout the body of this manual where applicable.

 <h2 style="margin: 0;">WARNING</h2>	
  	<p>SKIN INJECTION HAZARD</p> <p>High-pressure fluid from gun, hose leaks, or ruptured components will pierce skin. This may look like just a cut, but it is a serious injury that can result in amputation. Get immediate surgical treatment.</p> <ul style="list-style-type: none"> • Do not spray without tip guard and trigger guard installed. • Engage trigger lock when not spraying. • Do not point gun at anyone or at any part of the body. • Do not put your hand over the spray tip. • Do not stop or deflect leaks with your hand, body, glove, or rag. • Follow the Pressure Relief Procedure when you stop spraying and before cleaning, checking, or servicing equipment. • Tighten all fluid connections before operating the equipment. • Check hoses and couplings daily. Replace worn or damaged parts immediately.
 	<p>MOVING PARTS HAZARD</p> <p>Moving parts can pinch, cut or amputate fingers and other body parts.</p> <ul style="list-style-type: none"> • Keep clear of moving parts. • Do not operate equipment with protective guards or covers removed. • Pressurized equipment can start without warning. Before checking, moving, or servicing equipment, follow the Pressure Relief Procedure and disconnect all power sources.
   	<p>FIRE AND EXPLOSION HAZARD</p> <p>Flammable fumes, such as solvent and paint fumes, in work area can ignite or explode. To help prevent fire and explosion:</p> <ul style="list-style-type: none"> • Use equipment only in well ventilated area. • Eliminate all ignition sources; such as pilot lights, cigarettes, portable electric lamps, and plastic drop cloths (potential static arc). • Keep work area free of debris, including solvent, rags and gasoline. • Do not plug or unplug power cords, or turn power or light switches on or off when flammable fumes are present. • Ground all equipment in the work area. See Grounding instructions. • Use only grounded hoses. • Hold gun firmly to side of grounded pail when triggering into pail. Do not use pail liners unless they are antistatic or conductive. • Stop operation immediately if static sparking occurs or you feel a shock. Do not use equipment until you identify and correct the problem. • Keep a working fire extinguisher in the work area.

WARNING

  	<p>EQUIPMENT MISUSE HAZARD</p> <p>Misuse can cause death or serious injury.</p> <ul style="list-style-type: none"> • Do not operate the unit when fatigued or under the influence of drugs or alcohol. • Do not exceed the maximum working pressure or temperature rating of the lowest rated system component. See Technical Data in all equipment manuals. • Use fluids and solvents that are compatible with equipment wetted parts. See Technical Data in all equipment manuals. Read fluid and solvent manufacturer's warnings. For complete information about your material, request MSDS from distributor or retailer. • Do not leave the work area while equipment is energized or under pressure. • Turn off all equipment and follow the Pressure Relief Procedure when equipment is not in use. • Check equipment daily. Repair or replace worn or damaged parts immediately with genuine manufacturer's replacement parts only. • Do not alter or modify equipment. Alterations or modifications may void agency approvals and create safety hazards. • Make sure all equipment is rated and approved for the environment in which you are using it. • Use equipment only for its intended purpose. Call your distributor for information. • Route hoses and cables away from traffic areas, sharp edges, moving parts, and hot surfaces. • Do not kink or over bend hoses or use hoses to pull equipment. • Keep children and animals away from work area. • Comply with all applicable safety regulations.
	<p>SPLATTER HAZARD</p> <p>Hot or toxic fluid can cause serious injury if splashed in the eyes or on skin. During blow off of platen, splatter may occur.</p> <ul style="list-style-type: none"> • Use minimum air pressure when removing platen from drum.
	<p>TOXIC FLUID OR FUMES HAZARD</p> <p>Toxic fluids or fumes can cause serious injury or death if splashed in the eyes or on skin, inhaled, or swallowed.</p> <ul style="list-style-type: none"> • Read MSDSs to know the specific hazards of the fluids you are using. • Store hazardous fluid in approved containers, and dispose of it according to applicable guidelines.
	<p>PERSONAL PROTECTIVE EQUIPMENT</p> <p>Wear appropriate protective equipment when in the work area to help prevent serious injury, including eye injury, hearing loss, inhalation of toxic fumes, and burns. This protective equipment includes but is not limited to:</p> <ul style="list-style-type: none"> • Protective eyewear, and hearing protection. • Respirators, protective clothing, and gloves as recommended by the fluid and solvent manufacturer

Component Identification

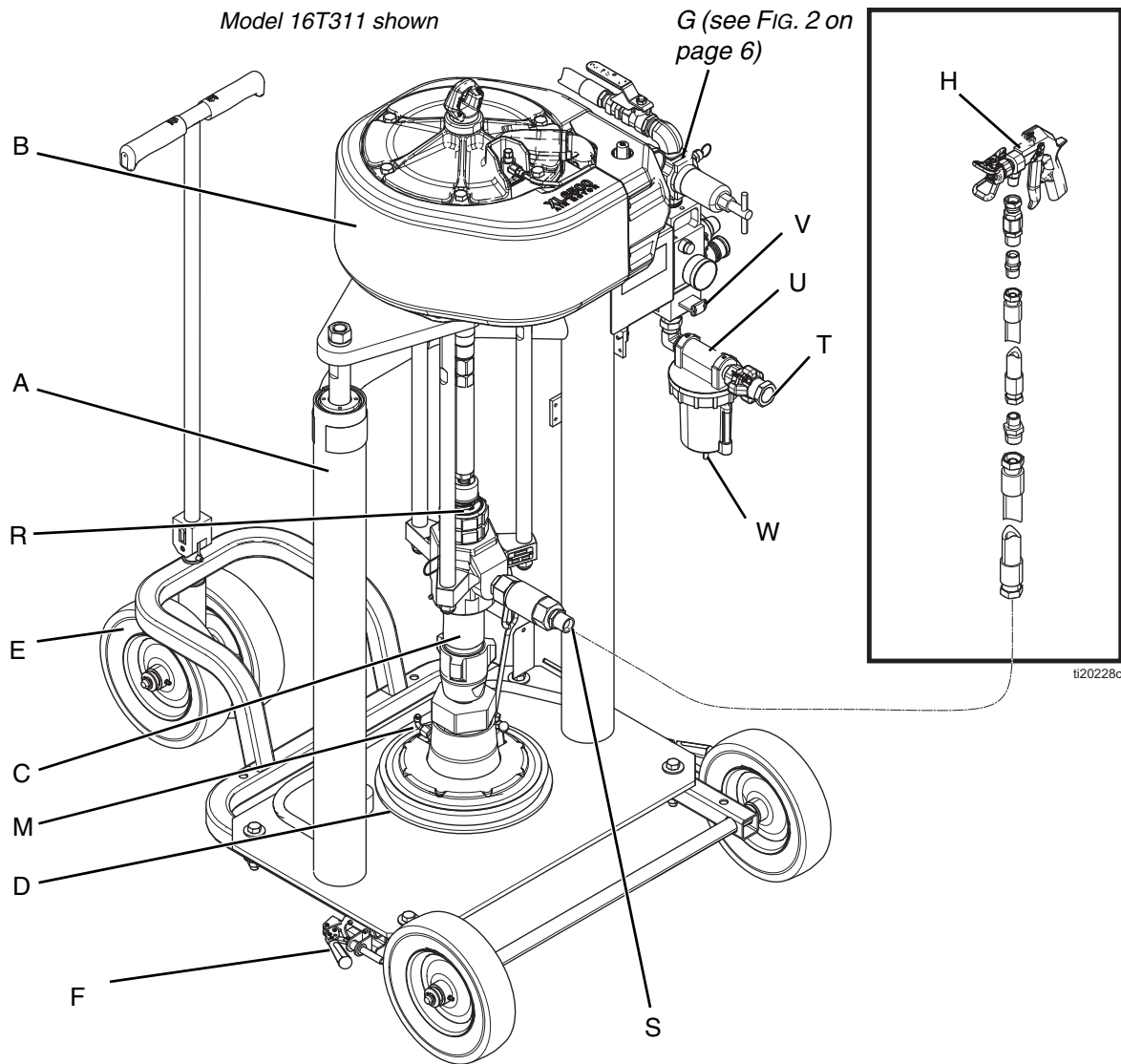

FIG. 1

Key:

- | | | | |
|---|--|---|--------------------------------|
| A | Ram Assembly | H | Spray Gun |
| B | Air Motor | M | Blowoff Air Supply Line |
| C | Displacement Pump | R | Wet Cup |
| D | Platen (see FIG. 3 on page 7) | S | Fluid Outlet |
| E | Cart | T | Main Air Inlet |
| F | Cart Brake | U | Air Filter and Water Separator |
| G | Integrated Air Controls (see FIG. 2 on page 6) | V | Bleed Type Air Shutoff Valve |
| | | W | Air Line Drain Valve |

Integrated Air Controls

The integrated air controls include:

- **Main air slider valve (BA):** turns air on and off to the system. When closed, the valve relieves pressure downstream.
- **Ram air regulator (BB):** controls ram up and down pressure and blowoff pressure.
- **Ram director valve (BC):** controls ram direction.
- **Exhaust port with muffler (BD)**
- **Air motor regulator (BE):** Controls air pressure to motor.
- **Air motor ball valve (BF):** turns air on and off to the air motor. When closed, the valve relieves air trapped between it and the air motor.
- **Blowoff button (BG):** turns air on and off to push the platen out of an empty drum.

Air Line Accessories

See FIG. 1 on page 5.

- **Air line drain valve (W)**
- **Air line 40 micron filter (U):** removes harmful dirt and moisture from compressed air supply.
- **Air relief valve** (attached to ram air regulator, not visible): automatically relieves excessive pressure.

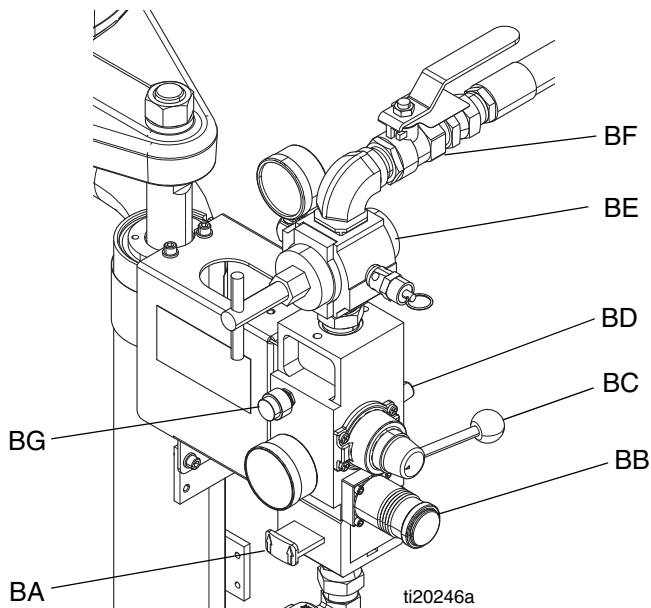

FIG. 2. Integrated Air Controls

Platen Component Identification

Model 16U676, 20 liter (5 gallon)

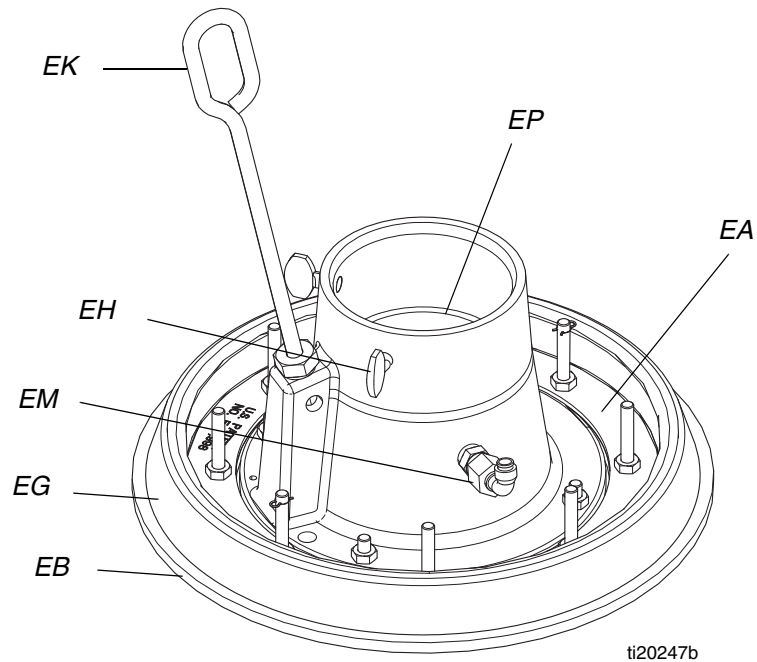

FIG. 3

Key:

- EA Retainer Clamp
- EB Wiper
- EG Spacer
- EH Thumb Screws
- EK Bleed Stick
- EM Air Assist Body Check Valve
- EP O-ring Seal (assembles to platen adapter, not shown)

Installation

General Information

NOTE: Reference numbers and letters in parentheses in the text refer to the callouts in the figures.

Accessories are available from Graco. Make certain all accessories are adequately sized and pressure-rated to meet the system's requirements.

Location

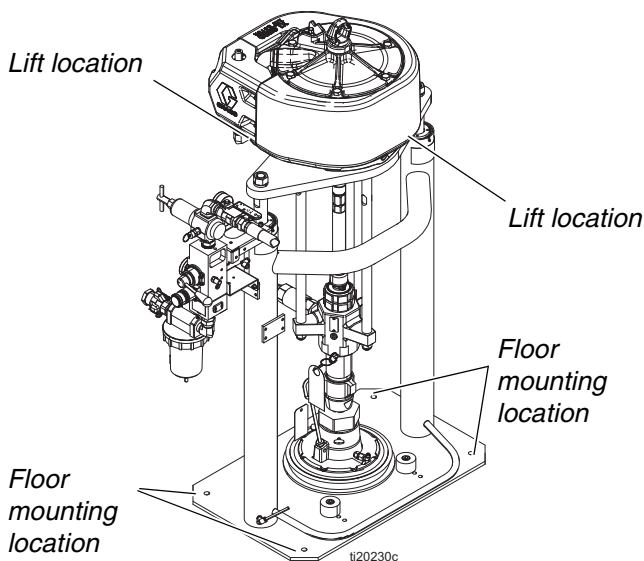

FIG. 4

Attach a lifting sling at the proper lift spots. Lift off the pallet using a crane or a forklift.

Position the ram so the air controls are easily accessible. Ensure that there is enough space overhead for the ram to raise fully. See **Dimensions**, page 31.

Set the brake on the cart before using the system.

Model 16P957 only: Using the holes in the ram base as a guide, drill holes for 1/2 in. (13 mm) anchors.

Model 16P957 only: Ensure that the ram base is level in all directions. If necessary, level the base using metal shims. Secure the base to the floor using 1/2 in. (13 mm) anchors that are long enough to prevent the ram from tipping.

Grounding

<p>The equipment must be grounded to reduce the risk of static sparking. Static sparking can cause fumes to ignite or explode. Grounding provides an escape wire for the electric current.</p>						

Pump: use the supplied ground wire and clamp. Connect other end of wire to a true earth ground. See FIG. 5.

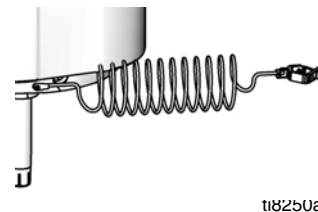

FIG. 5

Air and fluid hoses: use only electrically conductive hoses with a maximum of 500 ft. (150 m) combined hose length to ensure grounding continuity. Check electrical resistance of hoses. If total resistance to ground exceeds 25 megohms, replace hose immediately.

Air compressor: follow manufacturer's recommendations.

Spray gun/dispense valve: ground through connection to a properly grounded fluid hose and pump.

Fluid supply container: follow local code.

Object being sprayed: follow local code.

Solvent pails used when flushing: follow local code. Use only conductive metal pails that are properly grounded.

To maintain grounding continuity when flushing or relieving pressure: hold metal part of the dispense valve firmly to the side of a grounded metal pail, then trigger the valve.

Connect Mix Line and Gun

NOTE: Kit 24P832 includes items 5, 6, and 11-16 in FIG. 6.

1. If installing mix line and gun kit 24P832, install nipple (5), check valve (6), and second nipple (5) onto the pump outlet as shown in FIG. 6.
2. Connect the supplied 3/4 in. hose (11) to the nipple (5). See FIG. 6.
3. Use reducing nipple (12) to connect the supplied 1/2 in. whip hose (13) to the 3/4 in. hose (11).
4. Use nipple (14) to connect gun swivel (15) to whip hose (13).
5. Connect gun (16) to gun swivel (15).

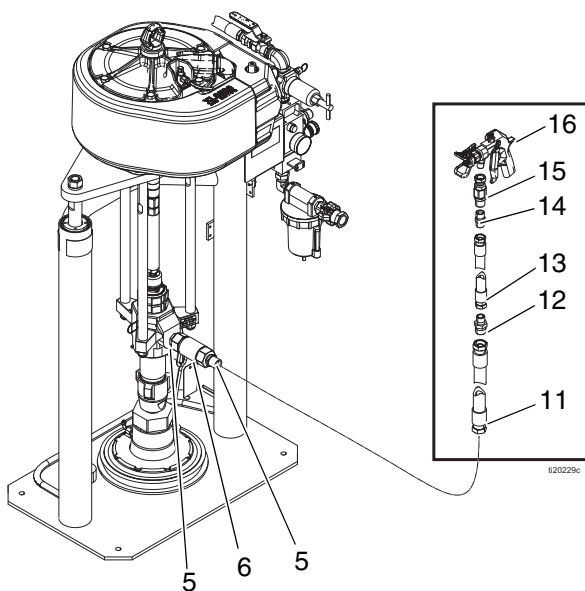

FIG. 6

Mechanical Setup

1. Fill displacement pump wet cup 2/3 full with Graco Throat Seal Liquid (TSL™).
2. Back-off air regulators to their full counterclockwise position and close all shutoff valves.
3. Connect air line from an air source to the system air inlet. See FIG. 1. Use a supply hose capable of meeting the required flow.

NOTE: Quick disconnects restrict flow for large air motors.

Attach Drum Stops

This unit is shipped with drum stops in place to help position the drum on the ram. For replacement parts, order Kit 255477. The kit includes 2 each of capscrews (FA), lock washers (not shown), and drum stops (FB).

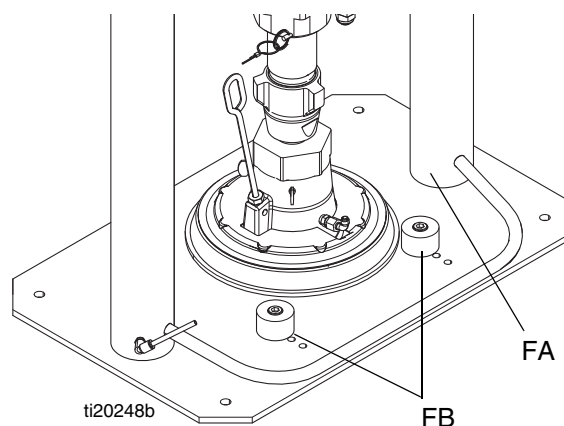

FIG. 7

1. Locate the correct set of mounting holes on the ram base.
2. Using the capscrews (FA) and lock washers (not shown), attach the drum stops (FB) to the ram base.

NOTE: Only use the 5 gallon drum stop position shown in FIG. 8.

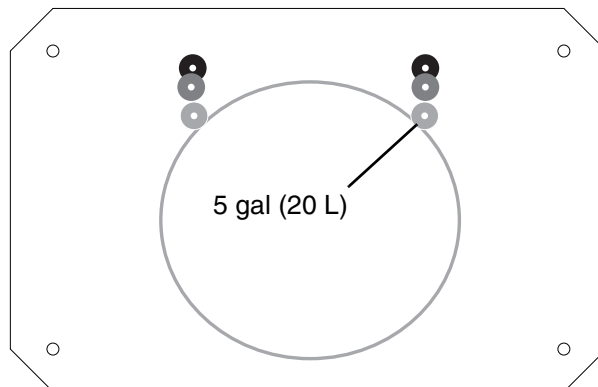



FIG. 8: Ram Base





Supply System Operation

Before Operating

NOTICE					
<p>To prevent mixed material from fully curing in the system requiring replacement of all parts containing cured material, always be prepared to immediately begin flushing at the first sign of material curing in the system and immediately after spraying stops. See Flush on page 12.</p>					

Pressure Relief Procedure

 Follow the Pressure Relief Procedure whenever you see this symbol.

						
<p>This equipment stays pressurized until pressure is manually relieved. To help prevent serious injury from pressurized fluid, such as skin injection, splashing fluid and moving parts, follow the Pressure Relief Procedure when you stop spraying and before cleaning, checking, or servicing the equipment.</p>						

1. Lock the gun/valve trigger.
2. See FIG. 2, page 6.
 - a. Close the air motor ball valve (BF) and the main air slider valve (BA).
 - b. *If the RAM is in a raised position*, set the ram director valve (BC) to DOWN. The ram will slowly drop.
 - c. Jog the director valve up and down to bleed air from ram cylinders.
3. Unlock the gun/valve trigger.
4. Hold a metal part of the gun/valve firmly to the side of a grounded metal pail, and trigger the gun/valve to relieve pressure.

5. Lock the gun/valve trigger.

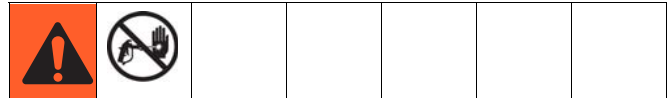

If you suspect that the spray tip/nozzle or hose is completely clogged, or that pressure has not been fully relieved after following the steps above, very slowly loosen the tip guard retaining nut or hose end coupling and relieve pressure gradually, then loosen completely. Now clear the tip/nozzle or hose.

Flush Before Using Equipment

*The pump was tested with lightweight oil, which is left in the fluid passages to protect parts. To avoid contaminating fluid with oil, flush the pump with a compatible solvent before use. See **Flush** on page 12.*

NOTICE					
<p>Prolonged exposure to solvent will reduce the life of the wiper. For maximum performance, do NOT soak platen soft parts in solvent. Instead, gently wipe down soft parts with solvent.</p>					

Start and Adjust Ram

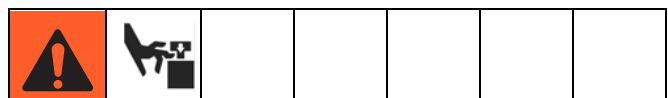

Moving parts can pinch or amputate fingers. When the pump is operating and when raising or lowering the ram, keep fingers and hands away from the pump intake, platen, and lip of the drum.

1. Set platen configuration based on pail type (see **Adjust Spacers**, page 13).
2. Refer to FIG. 1 and FIG. 2. Close all air regulators and air valves.
3. Open main air slider valve (BA) and set ram air regulator (BB) to 45 psi (0.31 MPa, 3.1 bar). Set director valve handle (BC) to UP and let the ram rise to its full height.
4. Remove the drum cover.

- Put a full drum of fluid on the ram base, slide it back against the drum stops, and center it under the platen (D). See FIG. 9.

NOTICE

To avoid damage to the platen seals, do not use a drum that is dented or damaged.

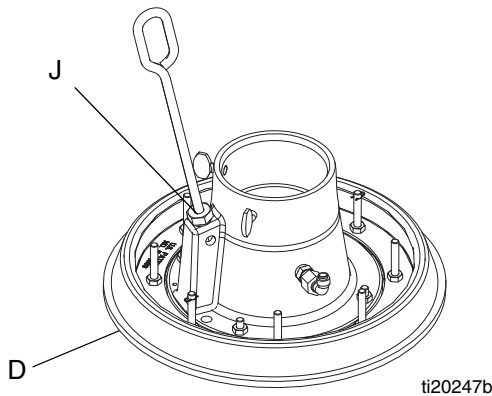

FIG. 9

- Remove bleed stick from platen bleed port (J).

NOTE: Some pails may require the spacer (EG) to be flipped upside down so the smaller diameter side is on the bottom. If unable to get ram into the pail, see **Remove and Reinstall Wiper** on page 14 to re-install the spacer upside down.
- Set the director valve (BC) to DOWN and lower the ram until fluid appears at the top of the platen bleed port (J). Adjust ram air regulator (BB) as needed. Set the director valve (BC) to neutral and close the platen bleed port (J).

Start and Adjust Pump

--	--	--	--	--	--

To prevent equipment rupture, be sure all components are adequately sized and pressure rated to meet the system's requirements.

- Start and Adjust Ram**, page 10. Keep the director valve (BC) set to DOWN while pump is operating.

- Be sure the main air slider valve (BA) is closed. Then set the ram air regulator (BB) to about 40-45 psi (0.28-3.1 MPa, 2.8-3.1 bar). Set the director valve (BC) to DOWN.
- Open main air slider valve (BA). Use air motor regulator (BE) to slowly increase pressure until pump operates at desired flow rate.

NOTE: Increase air pressure to the ram if the pump does not prime properly with heavier fluids. Decrease Ram air pressure if fluid is forced out around the top seal or platen.

Change Drums

--	--	--	--	--	--

Excessive air pressure in the material drum could cause the drum to rupture, causing serious injury. The platen must be free to move out of the drum. Never use drum blowoff air with a damaged drum.

- Close the air motor ball valve (BF) to stop the pump.
- Press and hold the blowoff air button (BG) then set ram director valve (BC) to UP to raise the platen (D) until the platen (D) is completely out of drum. When the ram exits the pail, release the blowoff air button to allow the ram to rise to its full height. Use minimum amount of air pressure necessary to push the platen out of the drum.
- Remove empty drum.
- Inspect platen and, if necessary, remove any remaining material or material build-up.
- Place full drum on ram base.
- Lower the ram and adjust the position of the drum relative to the platen. See **Start and Adjust Ram** on page 10.

NOTICE

To prevent material from curing in the system, immediately flush the system when a pressure drop is noticed during spraying and when done spraying.

Flush



1. Remove platen from pump, then submerge pump into solvent. To clean platen, gently wipe with solvent. **NOTE:** Read notice table in **Flush Before Using Equipment** section, page 10.
2. Perform **Start and Adjust Ram** on page 10 to pressurize the pump with solvent.
3. Hold gun firmly against a grounded pail and trigger gun into pail until clean solvent dispenses.

Shutdown and Care of the Pump

1. Set the ram director valve (BC) to DOWN.
2. Follow the **Pressure Relief Procedure** on page 10.
3. Follow the pump shutdown instructions in Xtreme lowers manual. See **Related Manuals** on page 2.

Replace Throat Seals

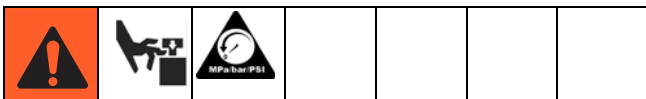

Remove wet cup from displacement pump while attached to the ram to replace throat seals.

1. Follow the **Pressure Relief Procedure** on page 10.
2. **Remove Quick Coupler.**
3. Remove wet cup and packing cartridge according to instructions in Xtreme lowers manual. See **Related Manuals** on page 2.

Remove Quick Coupler

1. Ensure displacement pump is at bottom of stroke.
2. Follow the **Pressure Relief Procedure** on page 10.
3. Remove clip (GC), and slide coupling cover (GB) up to remove coupling (GA).

Xtreme Coupler

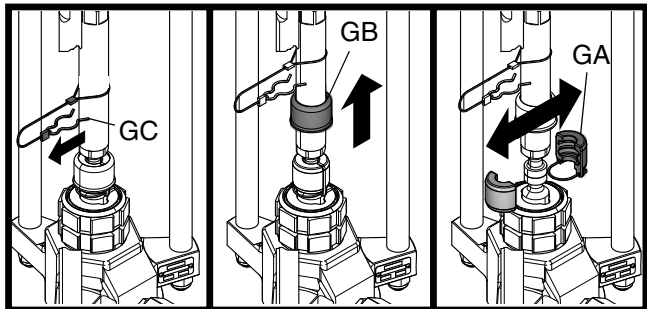

ti20249a

Xtreme XL Coupler

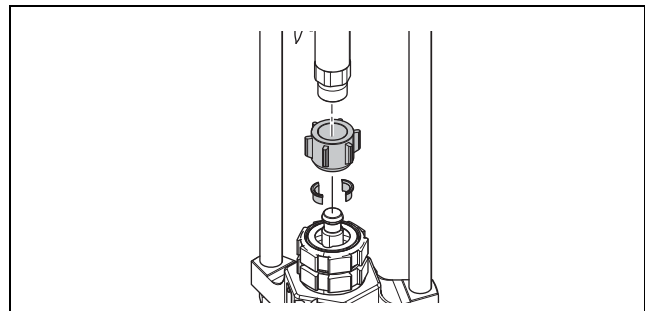

Before Beginning Repair

Maintenance Procedures

						
<p>To reduce the risk of serious injury whenever you are instructed to relieve pressure, always follow the Pressure Relief procedure.</p>						

Platen Maintenance

See FIG. 10. If the platen does not come out of the pail easily when the pump is being raised, the air assist tube (EF) or air assist check valve may be plugged, or the bleed stick (J) may not be tightened. A plugged air assist check valve prevents air from reaching the underside of the plate to assist in raising it from the pail. If the bleed stick is not tightened no pressure will build.

1. Follow the **Pressure Relief Procedure** on page 10. Refer to platen assembly illustration on page 15 and disassemble air assist check valve (414) as shown.
2. Clear air assist tube (EF) in platen. Clean all parts of air assist check valve (414) and reassemble.
3. Remove bleed stick (J) from platen. Push bleed stick through bleed relieve ports to remove material residue.

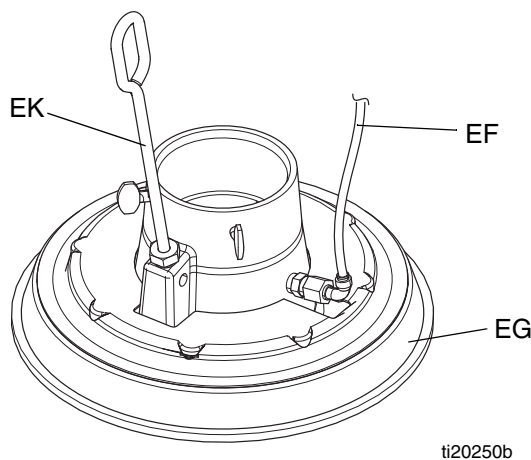

FIG. 10

Adjust Spacers

Use Platen with Tapered and Straight Sided Pails

Use platen with tapered pails

1. Working from the bottom, use screwdriver to pry spacer (EG) loose. Work spacer upward completely above the flange of the platen. See FIG. 11.
2. By hand, angle spacer (EG) and work it off the plate, pulling it down over the flange. See FIG. 12.
3. Save spacer (EG), as it is required for other applications.

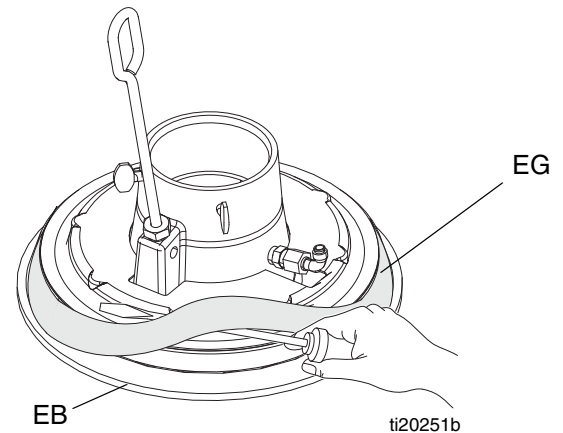

FIG. 11

Use platen with straight sided pail

1. Ensure large diameter of spacer (EG) is facing **down**. Work spacer (EG) up over the platen by hand completely above the flange of the platen. See FIG. 12.
2. Working from the top, use screwdriver to position spacer (EG) between flange and wiper (EB). See FIG. 13.

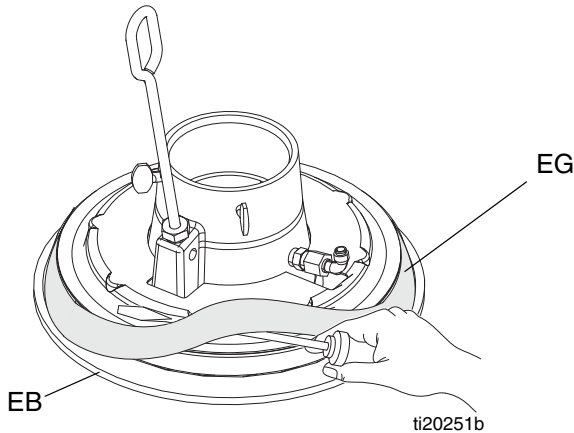

FIG. 12: Sliding spacer

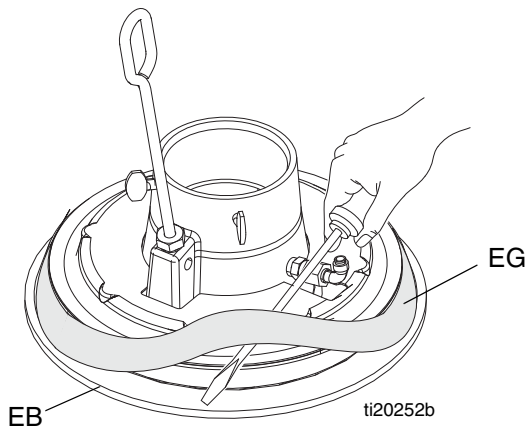

FIG. 13: Installing Spacer

Remove and Reinstall Wiper

1. Remove wiper assembly; see FIG. 14:
 - a. Remove two clips (420) with needle nose pliers and remove platen cover (419).
 - b. Remove four nuts (409) that hold wiper assembly to platen casting (407) and remove wiper assembly.
 - c. See **Reassemble 20 Liter Wiper Assembly** to change wiper styles or a complete wiper assembly.
2. Remove eight nuts (409) on wiper assembly.
3. Separate top plate (407), spacer (402), wiper (403), and bottom plate (405).
4. Clean, inspect, and replace worn components.

Reassemble 20 Liter Wiper Assembly

1. Place bottom plate (405) on flat surface. Place wiper (403), spacer (402), and top plate (407) on bottom plate (405).
2. Install eight nuts (409) on outer ring. Torque to 40-50 in-lb (4.5-5.6 N•m).
3. Replace o-ring (406), or install new o-ring under platen casting (401). Use lubricant to hold in place.
4. Install platen casting (401). Tighten with four nuts (409). Torque to 40-50 in-lb (4.5-5.6 N•m).

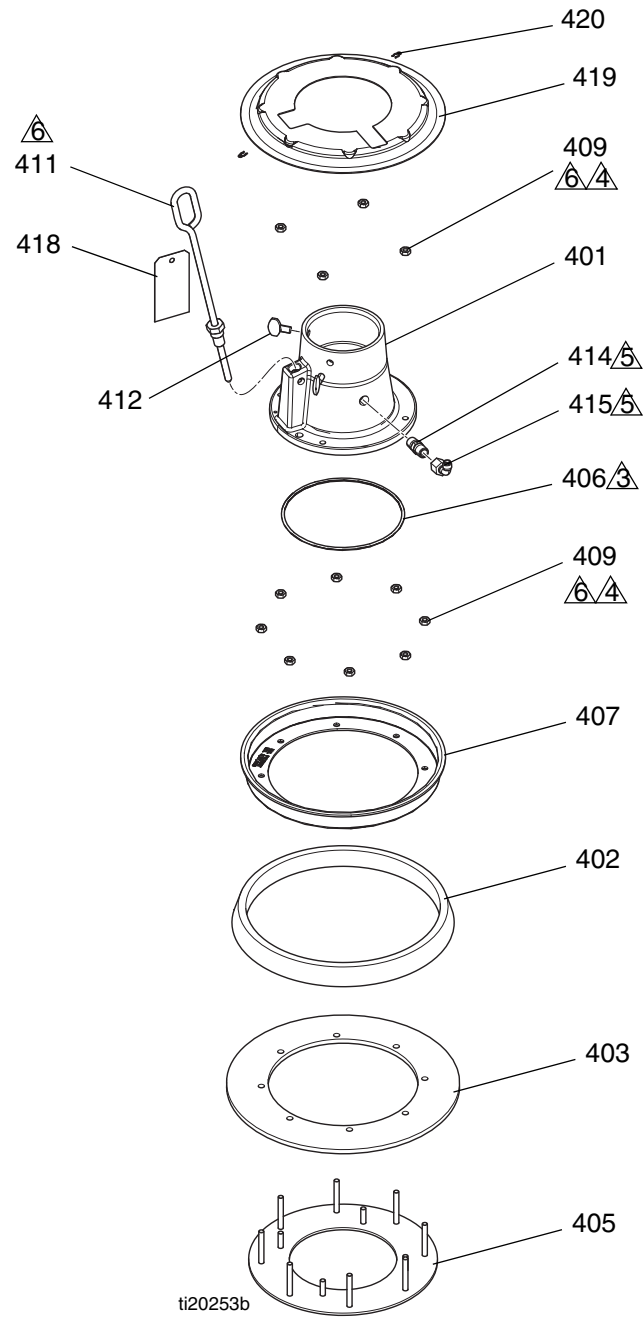





-  Apply grease to hold ring (406) in place during assembly.
-  Torque to 40-50 in-lb (4.5-5.6 N•m).
-  Apply pipe sealant to all non-swiveling pipe threads.
-  Apply thread lubricant to threads.

FIG. 14: Platen Assembly

Troubleshooting

Check all possible problems before disassembling the ram, pump, or platen. Refer to **Xtreme Pump Packages** manual 311762 for pump troubleshooting.

Ram

Problem	Cause	Solution
Decreasing spraying pressure or poor spray pattern.	Material beginning to cure in lines.	Flush immediately.
Ram will not raise or lower.	Closed air valve or clogged air line.	Open, clear.
	Not enough air pressure.	Increase.
	Worn or damaged piston.	Replace. See Supply Unit Repair on page 20.
	Hand valve closed or clogged.	Open, clear.
Ram raises and lowers too fast.	Air pressure is too high.	Decrease.
Air leaks around cylinder rod.	Worn rod seal.	Replace. See Supply Unit Repair on page 20.
Fluid squeezes past ram plate wipers.	Air pressure too high.	Decrease.
	Worn or damaged wipers.	Replace. See Remove and Reinstall Wiper on page 14.
Pump will not prime properly or pumps air.	Closed air valve or clogged air line.	Open, clear.
	Not enough air pressure.	Increase.
	Worn or damaged piston.	Replace. See pump manual.
	Hand valve closed or clogged.	Open, clear. See Platen Maintenance on page 13.
	Hand valve is dirty, worn, or damaged.	Clean, service.
Air assist valve will not hold drum down or push plate up.	Closed air valve or clogged air line.	Open, clear. See Platen Maintenance on page 13.
	Not enough air pressure.	Increase.
	Valve passage clogged.	Clean. See Platen Maintenance on page 13.

Repair

Disconnect Pump from Platen

1. Loosen two thumb screws (412) from platen.
2. Carefully pull pump away to prevent damage to pump inlet. Remove adapter (421) and o-ring (406) from platen adapter (421).

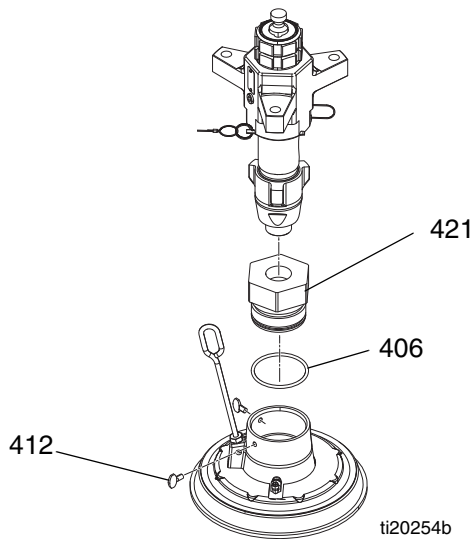

FIG. 15

Connect Platen to Pump

1. Apply grease to o-ring (406) then install the o-ring on platen adapter (421). See FIG. 15.
2. Apply pipe sealant to pump inlet thread then thread onto adapter (421).
3. Loosen thumb screws (412) then carefully lower pump onto platen.
4. Tighten thumb screws (412) to secure platen to adapter.

Remove Wipers

See *Remove and Reinstall Wipers* on page 13.

Install Wipers

See *Remove and Reinstall Wipers* on page 13.

Disconnect Displacement Pump

1. Remove **Quick Coupler**, page 12.
2. Remove tie rod nuts (206).

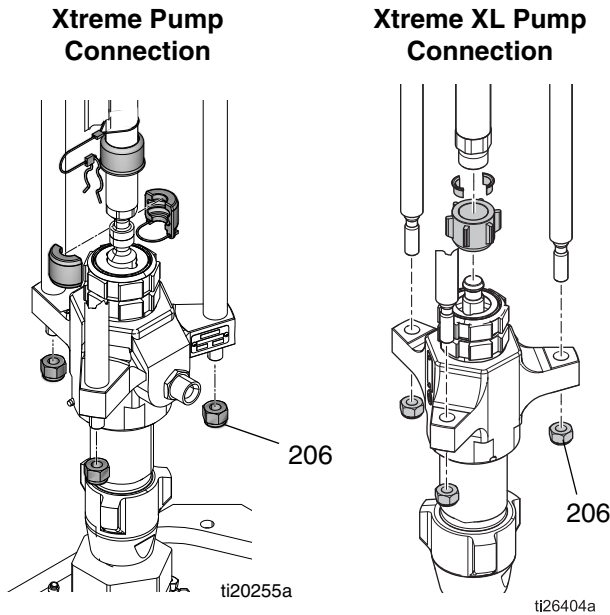

FIG. 16

Install Displacement Pump

1. Raise ram to install displacement pump to platen.
2. **Connect Platen to Pump**, page 17.
3. **Connect Displacement Pump**, page 18.

Connect Displacement Pump

1. Install tie rod nuts (206). Torque to 50-60 ft-lb (68-81 N•m).
2. Install quick coupler.

3. Lift air motor rod to bring rod to top of stroke.

Remove Displacement Pump

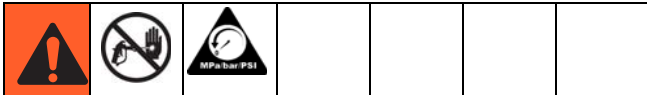

Refer to your *Xtreme Displacement Pump 311762* manual to repair the displacement pump.

If the air motor does not require servicing, leave it attached to its mounting. If the air motor does need to be removed, see page 19.

1. Follow the **Pressure Relief Procedure** on page 10.
2. **Disconnect Displacement Pump**, page 18.
3. **Disconnect Pump from Platen**, page 17 to disconnect the platen from the displacement pump.
4. Raise the ram assembly to lift the air motor away from the displacement pump.
5. Remove displacement pump and service as needed.

Remove Air Motor



1. Follow the **Pressure Relief Procedure** on page 10.
2. **Disconnect Displacement Pump**, page 18.
3. Disconnect air hose from air motor fitting (7). See page 22.
4. **Remove Quick Coupler**, page 12.
5. Remove screws (3) and washers (2) that secure air motor to mounting plate (320).

Install Air Motor

1. Using a secure hoist, attach motor to mounting plate (320) with screws (3) and washers (2). See FIG. 17.
2. **Connect Displacement Pump**, page 18.
3. Connect air hose to air motor fitting (7). See page 22.

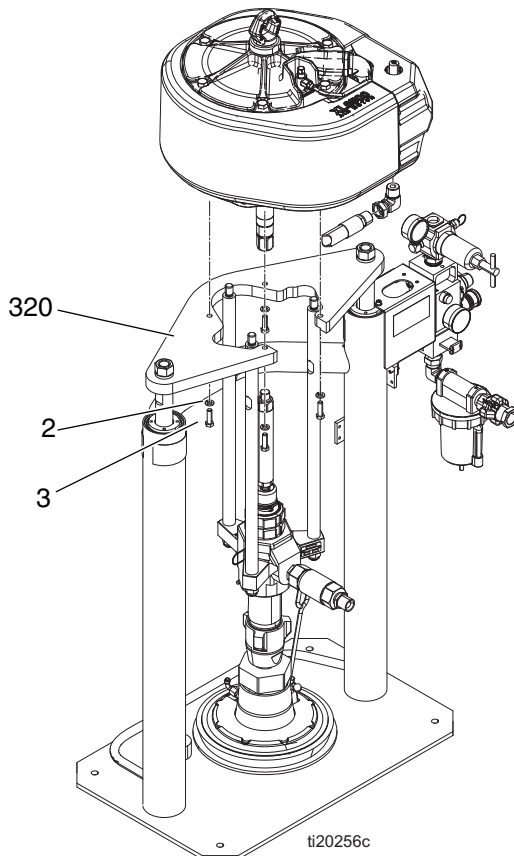





FIG. 17

6. Using a capable hoist connected to air motor lift ring, secure air motor to hoist and remove air motor.

Supply Unit Repair

						
---	---	---	--	--	--	--

To reduce the risk of serious injury whenever you are instructed to relieve pressure always follow the **Pressure Relief Procedure** on page 10. Do not use pressurized air to remove the guide sleeve or the piston.

Ram Piston Rods

Always service both cylinders at the same time. When you service the piston rod always install new o-rings in the piston rod seal and ram piston.

Repair Parts:

Piston Repair Kit 257622. See **Check Valve (16T481)** on page 27 for parts included in kit.

Disassemble Piston Rod Seal and Bearing

1. Relieve pressure.
2. Access piston rod seal and bearing.
 - a. Ensure ram is in lowest position.
 - b. Remove nuts (333) and lockwashers (332) from piston rods (302a).
 - c. Remove entire pump package, including the mounting plate (331) off of the piston rods (302a). Use a fork-truck to lift the assembly from the mounting plate.
 - d. Secure pump package so pump and platen will not fall.

3. Remove retaining ring (303).
4. Remove piston rod seal and bearing. Slide end cap (302b), pin (302c), o-ring (302d), and spring (302m) up off of the piston rod (302a). Remove retaining ring (302l) and bearing (302k) from end cap (302b) and remove o-ring (302e).
5. Inspect parts for wear or damage. Replace as necessary.

NOTE: Do not reinstall end cap assembly if the ram piston (302f) needs to be removed from the piston rod. See the next page for ram piston repair instructions.

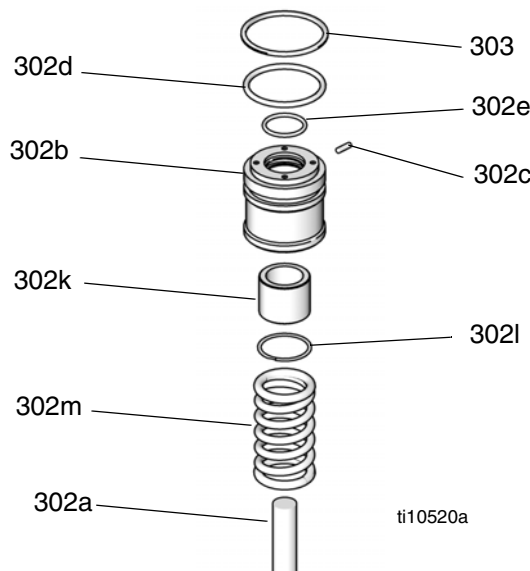

FIG. 18: 3 in. Piston Rod Seal

Assemble Piston Rod Seal and Bearing

See FIG. 18 on page 20.

1. Lubricate o-ring (302e) and bottom bearing (302k).
 - a. Install o-ring (302e), bottom bearing (302j), and retaining ring (302l) into end cap (302b).
 - b. Install new o-ring (302d) and pin (302c) on end cap (302b). Lubricate o-ring (302d) and end cap (302b).
 - c. Slide spring (302m) and end cap (302b) on piston rod (302a).
2. Install retaining ring (303).
3. Remount mounting plate (331) and attach nuts (333) and lockwashers (332). Torque to 40 ft-lb (54 N•m).

Disassemble Ram Piston

1. Complete steps 1-4 from **Disassemble Piston Rod Seal and Bearing** to remove the end cap (302b) from the piston rod (302a).

NOTICE

Do not tilt the piston rod to one side when removing it from the base or when installing it. Such movement can damage the piston or inside surface of the base cylinder.

2. Carefully lay piston (302f) and rod (302a) down so piston rod will not be bent. Remove nut (302g), washer (302h), piston (302f), outer o-ring (302d), and inner o-ring (302j). See FIG. 19.

3. Inspect parts for wear or damage. Replace as necessary.

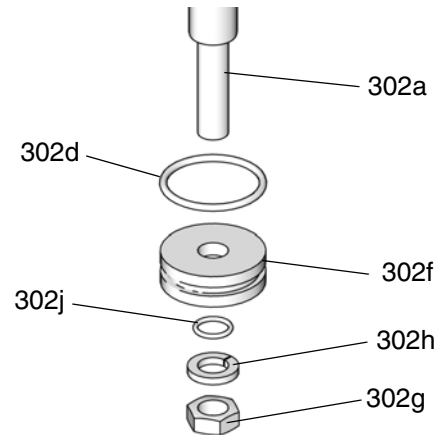

T110521A

FIG. 19: 3 in. Ram Piston

Assemble Ram Piston

1. Install new o-rings (302d, 302j) and lubricate piston (302f) and o-rings.
2. Apply medium strength thread sealant. Install piston (302f), washer (302h), and nut (302g) on piston rod (302a).
3. Carefully insert piston (302f) into cylinder and push piston rod (302a) straight down into cylinder.
4. Slide spring (302m) and end cap (302b) onto piston rod (302a).
5. Install retaining ring (303).
6. Remount mounting plate (331) and attach nuts (333) and lock washers (332). Torque to 40 ft-lb (54 N•m).

Parts

Xtreme PFP (16P957 and 16T311) Xtreme PFP (24X068 and 24X069)

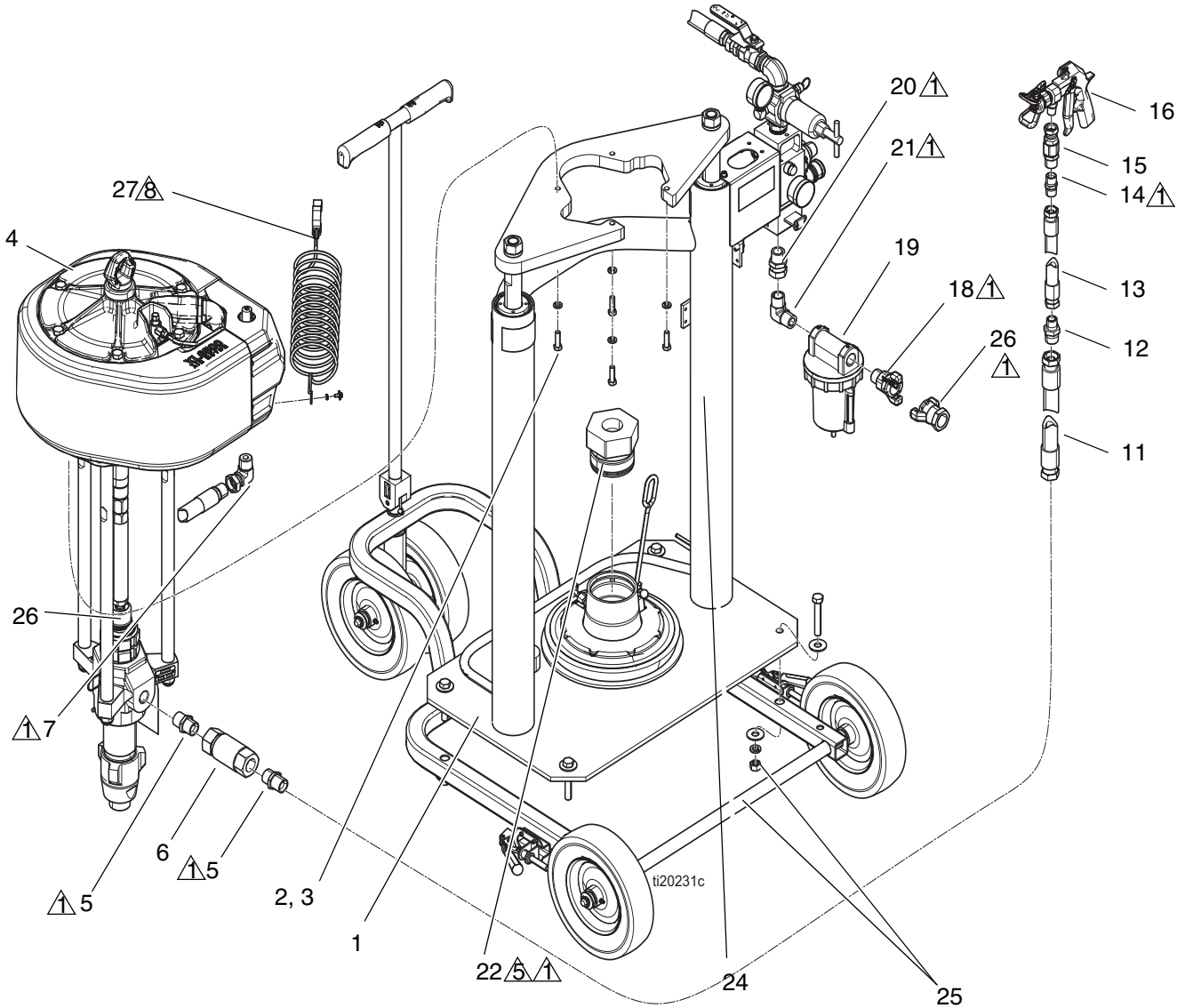

Xtreme PFP Shown

- ▲ Apply sealant (8) to all non-swiveling pipe threads.
- ⊗ Assemble o-ring (22a) from platen to platen adapter (22) then assemble platen to adapter.
- ⊗ Install grounding wire (27) to ground screw on motor (4).

Ref	Part	Description	Qty
1	---	RAM, dual post, motor regulator	1
2	100133	WASHER, lock, 3/8	4
3	---	SCREW, cap, hex head	4
4	---	PUMP, Xtreme, PFP; 16T311 and 16P957 only	1
	---	PUMP, Xtreme, XL; 24X068 and 24X069 only	1
5◆	160032	FITTING, nipple	2
6◆	16T481	VALVE, check	1
7	160327	FITTING, union adapter, 90 degree	1
8	---	SEALANT, pipe, stainless steel	1
10*	206994	FLUID, TSL, 8 oz bottle	1
11◆	H77550	HOSE, coupled, 7250 psi, 0.75 in. ID, 50 ft	1
12◆	16R883	FITTING, nipple, reducing, 3/4 x 1/2	1
13◆	H75025	HOSE, coupled, 7250 psi, 0.50 in. ID, 25 ft	1
14◆	158491	FITTING, nipple	1
15◆	17G980	SWIVEL, straight	1
16◆	262854	GUN, spray, XHF	1
18	113429	COUPLING, universal, 3/4-14 npt male	1
19	117628	FILTER, air, 3/4 (auto drain)	1
20	157785	FITTING, swivel	1
21	295847	FITTING, elbow, 90, 3/4 mpt	1
22	16P437	ADAPTER, platen	1
22a	112358	PACKING, o-ring	1
24	---	LABEL, identification	1
25	16P434	CART, ram (<i>Model 16T311 only</i>)	1
26	113430	COUPLING, universal, 3/4-14 npt female	1
27	238909	WIRE, grounding	1

--- Not for sale.

* Not shown.

◆ Included in mix line and gun kit 24P832. See **Connect Mix Line and Gun** on page 9 for kit installation.

Cart, 16P434

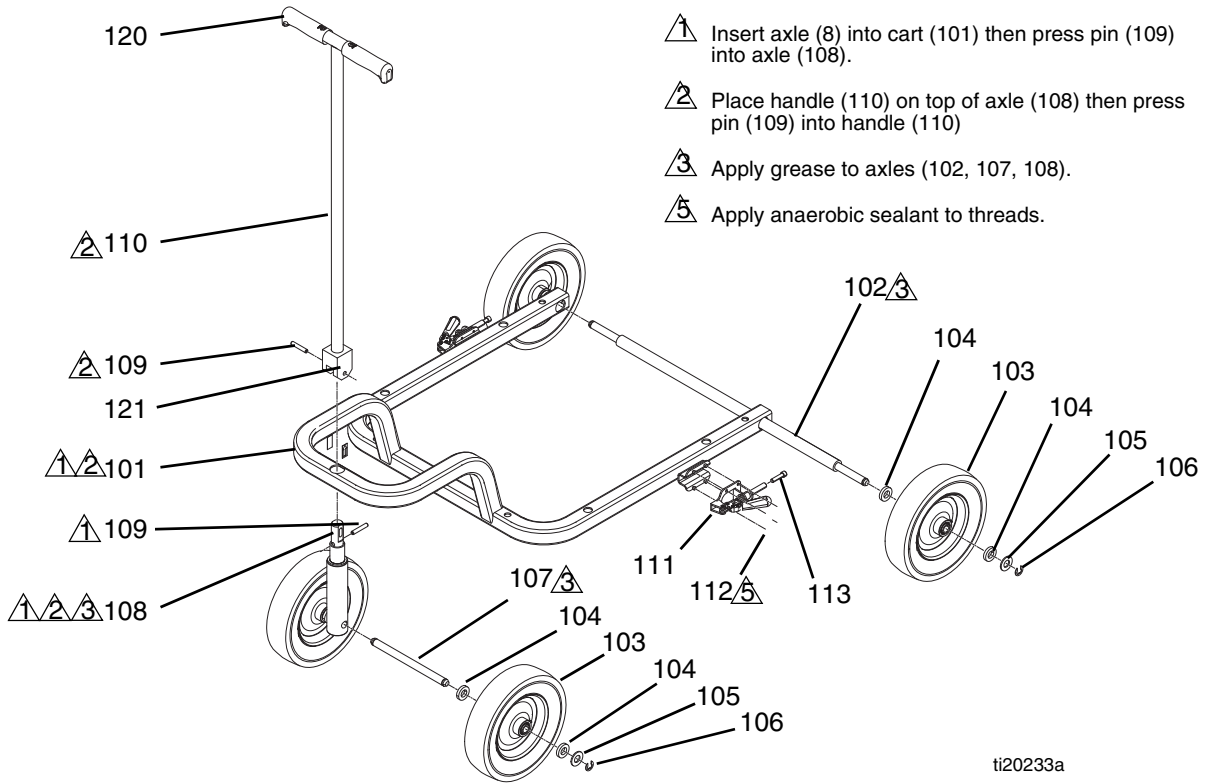

ti20233a

Ref	Part	Description	Qty	Ref	Part	Description	Qty
101	---	CART	1	113	102962	SCREW, cap, socket head	2
102	---	AXLE	1	114	---	LUBRICANT, grease	1
103	113807	WHEEL, flat free, urethane	4	115◆	101147	SCREW, cap, hex head	4
104	191824	WASHER, space	8	116◆	101044	WASHER, plain	8
105	111841	WASHER, plain 5/8	4	117◆	100018	WASHER, lock, spring	4
106	101242	RING, retaining, external	4	118◆	100321	NUT	4
107	15A913	AXLE	1	119	---	SEALANT, anaerobic	1
108	---	AXLE	1	120	116139	GRIP, handle	2
109	124291	PIN, spring	2	121	---	LABEL, arrow	2
110	258982	HANDLE, cart	1				
111	---	BRAKE	2				
112	112788	SCREW, cap, socket head	8				
						--- Not for sale.	
						◆ Not shown.	

Xtreme Pumpline 16P960 (for 16T311 and 16P957 systems)

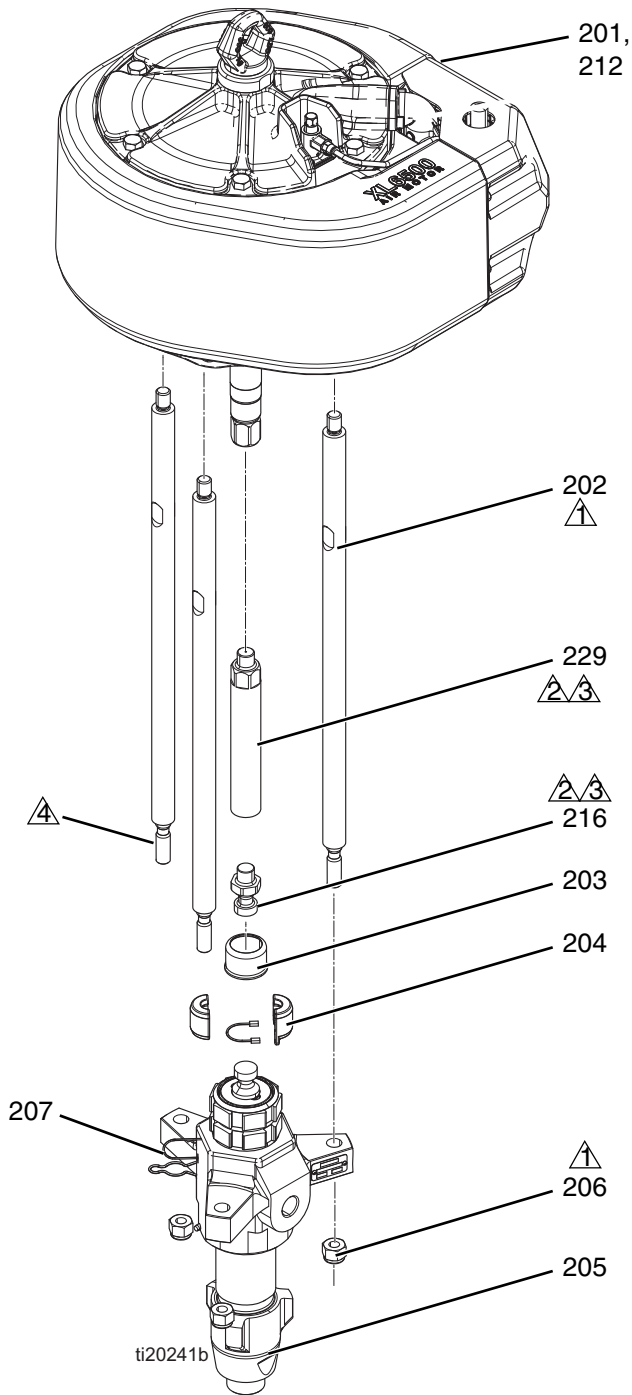

Ref	Part	Description	Qty
201	XL65D0M	MOTOR, 6500	1
202	16P436	ROD, tie	3
203	197340	COVER, coupler	1
204	244819	COUPLING, assembly	1
205	L180C7	LOWER, Xtreme	1
206	101712	NUT, lock	3
207	244820	CLIP, hairpin; with lanyard	1
208	---	SEALANT, anaerobic	1
212	---	LABEL, Xtreme PFP	1
214	---	LUBRICANT, thread	1
216	15H392	ADAPTER, rod, Xtreme	1
229	16P435	ROD, adapter	1

--- Not for sale.

- ① Torque to 50-60 ft-lb (68-81 N•m).
- ② Torque together to 145-155 ft-lb (196-210 N•m).
- ③ Apply sealant.
- ④ Insert lanyard from locking pin onto tie rod (2).
- ⑤ Apply thread lubricant to threads, o-rings, and seals. Do not apply to rod adapter (216) or rod (229).
- ⑦ Push in de-ice control (15) fully. Symbols must be upright.

Xtreme XL Pumpline, 24X067 (for 24X068 and 24X069 systems)

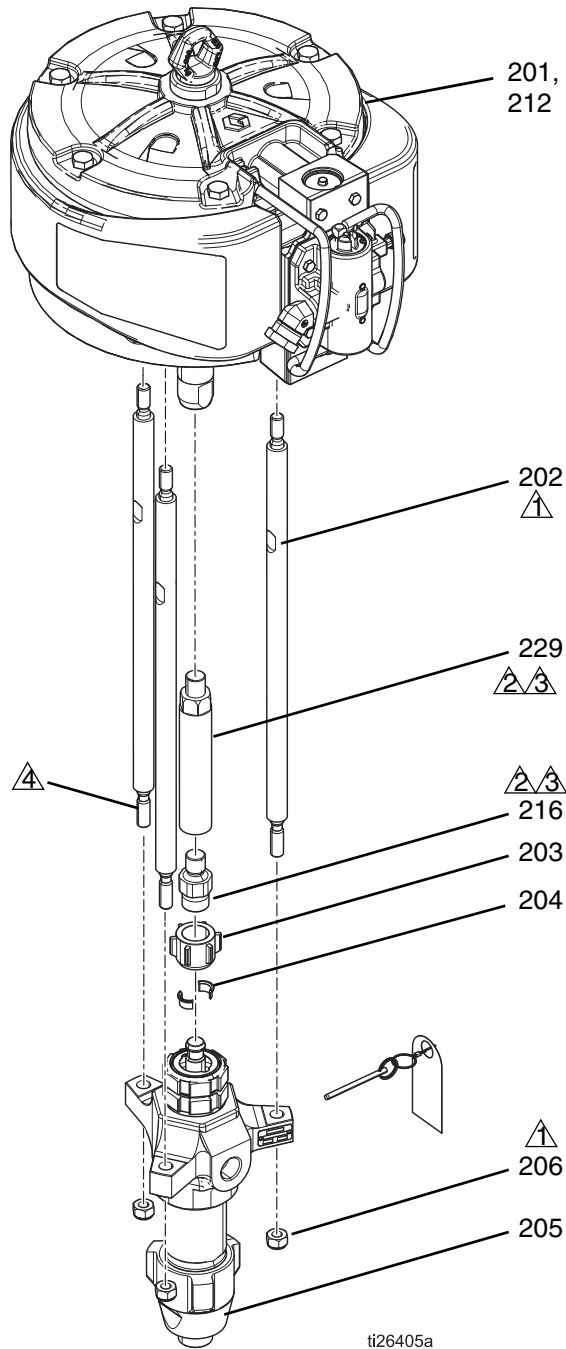



Ref	Part	Description	Qty
201	24X856	MOTOR, XL	1
202	17D232	ROD, tie	3
203	184129	COLLAR, coupling	2
204	184098	NUT, coupling	1
205	L29HC7	LOWER, Xtreme, 290	1
206	15U606	NUT, lock, M16 x 2	3
216	184583	ADAPTER, rod	1
229	17D231	ROD, adapter	1

--- Not for sale.

- 1 Torque to 50-60 ft-lb (68-81 N•m).
- 2 Torque together to 145-155 ft-lb (196-210 N•m).
- 3 Apply sealant.
- 4 Insert lanyard from locking pin onto tie rod (202).
- 5 Apply thread lubricant to threads, o-rings, and seals. Do not apply to rod adapter (216) or rod (229).

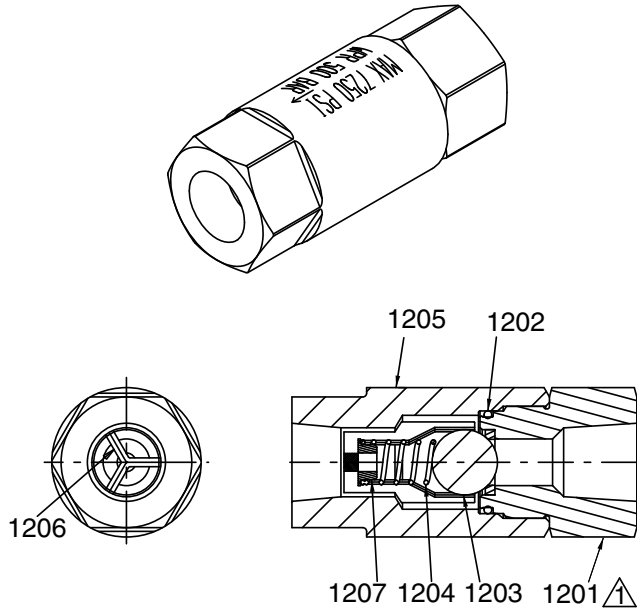
Check Valve (16T481)



 Torque to 75-80 ft-lb (102-108 N•m).

Ref.	Part	Description	Qty.
1201	---	NUT, seat	1
1202	102595	PACKING, o-ring	1
1203	100279	BALL, metallic	1
1204	108361	SPRING, compression	1
1205	---	HOUSING, ball check	1
1206	181492	GUIDE, ball	3
1207	181535	RETAINER, spring	1

--- Not for sale.

Ram Frame

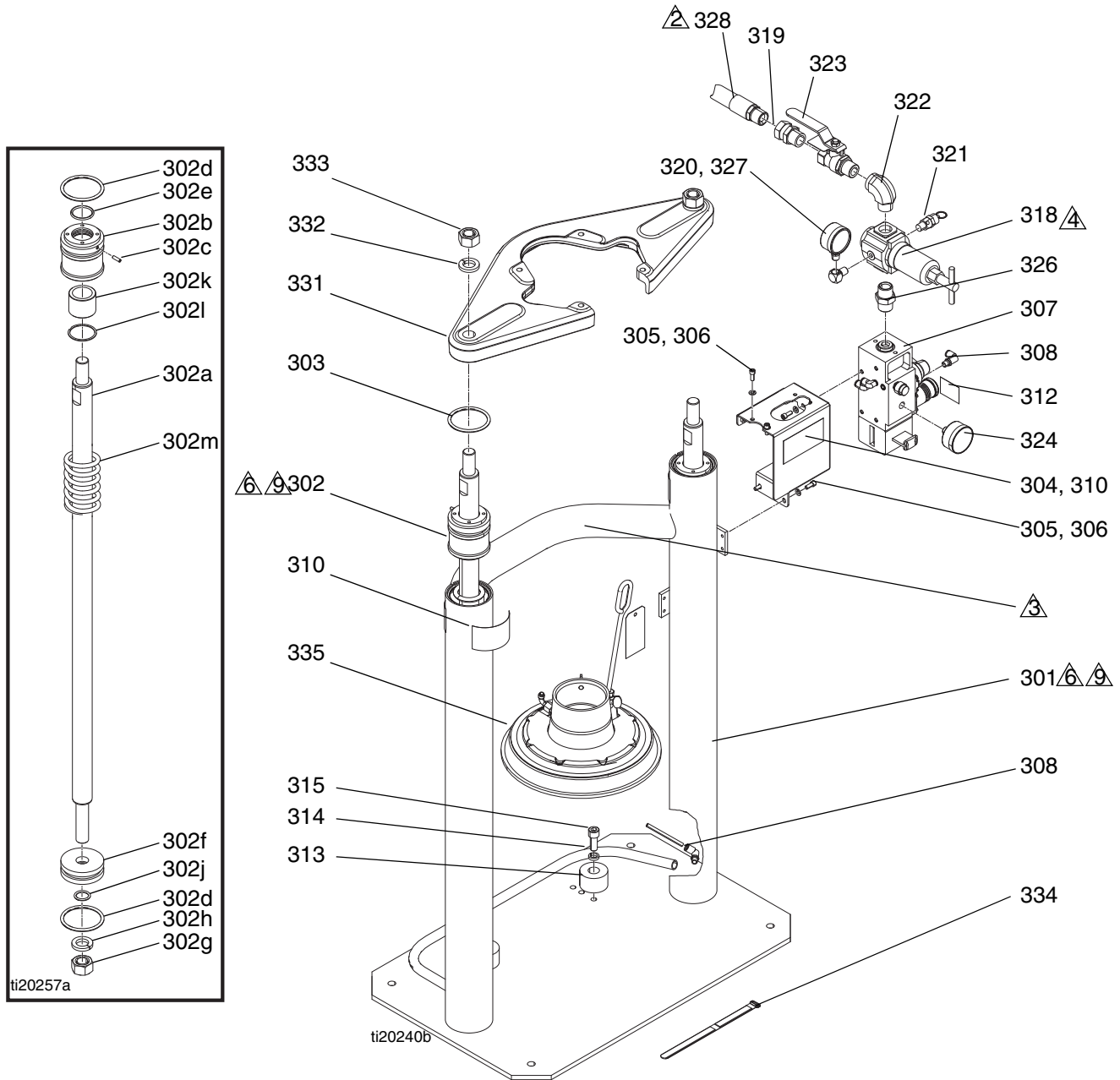

- 1 Apply pipe sealant to all non-swiveling pipe threads.
- 2 Apply electrical tape and protective sleeve (316) to hose (315) at motor end with blow-off assist air hose. Double-back the sleeve over itself. Tape the air control end last.
- 3 Attach strap (323) and hose-tube routing over rear cross bar.

- 4 Arrow on air regulator (304) must point towards elbow fitting (308).
- 6 Apply grease to all packings and cavity of RAM cylinder (301).
- 9 Add oil to cylinder (301) wall before and after piston assembly (302) is installed.

Ram Frame Parts

Ref	Part	Description	Qty	Ref	Part	Description	Qty
301	---	RAM, dp, weldment	1	331	---	BRACKET, shelf, D60, 3400 / 6500	1
302◆	---	PISTON, ram, subassembly (includes items 302a-302p)	2	332	101533	WASHER, spring lock	2
302a◆	---	ROD, piston, ram	1	333	101535	NUT, full hex	2
302b◆	15M295	BEARING, ram end cap	1	334	198442	STRAP, retaining mix manifold	1
302c◆	15U979	PIN, spring, straight	1	335	16U676	PLATE, 20 L single wiper; see manual 3A3113	1
302d◆	160258	PACKING, o-ring, buna-n	2	--- Not for sale.			
302e◆	156698	PACKING, o-ring	1	▲ Replacement Danger and Warning labels, tags and cards are available at no cost.			
302f◆	183943	PISTON	1	◆ Included in kit 257622.			
302g◆	101535	NUT, full hex	1				
302h◆	101533	WASHER, spring lock	1				
302j◆	156401	PACKING, o-ring	1				
302k◆	---	BEARING, ram end cap	1				
302l◆	15F453	RETAINER, retaining ring	1				
302m◆	160138	SPRING, compression	1				
302n◆	---	LUBRICANT, grease	1				
302p◆	---	SEALANT, thread, medium strength	1				
303◆	---	RING, retaining	2				
304	255296	BRACKET, mounted	1				
305	100016	WASHER, lock	8				
306	101682	SCREW, socket cap head	8				
307	24C824	CONTROL, air, ram, hydraulic driver; see manual 312374 for breakdown	1				
308	597151	FITTING, elbow	2				
309	---	LUBRICANT, grease	1				
310▲	15J074	LABEL, safety, crush and pinch	4				
311	---	SEALANT, pipe, sst	1				
312	---	LABEL, valve, shutoff, air control	1				
313	C32467	STOP, drum	2				
314	C38185	WASHER, lock	2				
315	C19853	SCREW, cap, socket head	2				
316	C12509	TUBE, nylon, round	14				
317	---	LUBRICANT, oil	1				
318	16F014	REGULATOR, air, t-handle	1				
319	157785	FITTING, swivel	1				
320	100960	GAUGE, pressure, air	1				
321	113498	VALVE, safety, 110 psi	1				
322	---	FITTING, elbow, street, 3/4-14	1				
323	113218	VALVE, ball, vented, 0.750	1				
324	101689	GAUGE, press, air	1				
326	C20487	FITTING, nipple, hex	1				
327	100840	FITTING, elbow, street	1				
328	C12034	HOSE, coupled 72 in.	1				
329	552071	SLEEVE, protective	15				
330	---	TAPE, electrical	1				

Accessories

Static Mixer Kit (16T316)

This is a 12 element, stainless steel, static mixer used to thoroughly mix the materials. The static mixer kit is installed between DD and EE.

Static Mixer Kit Installation:

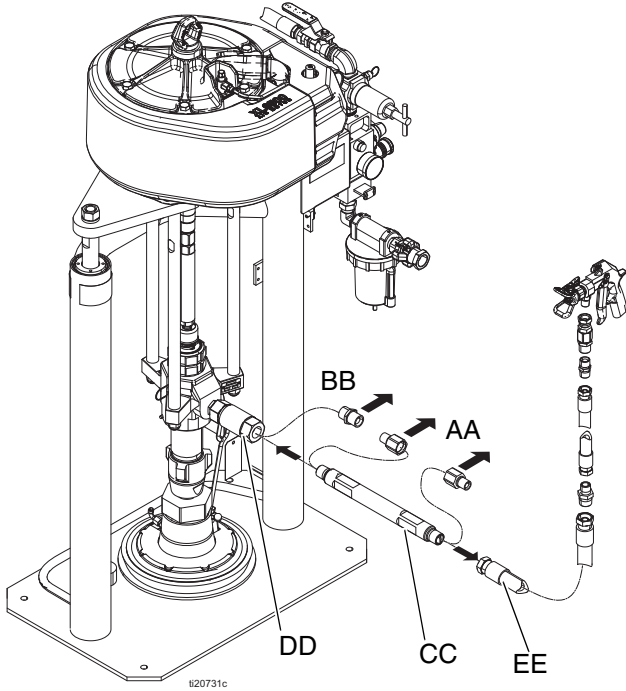
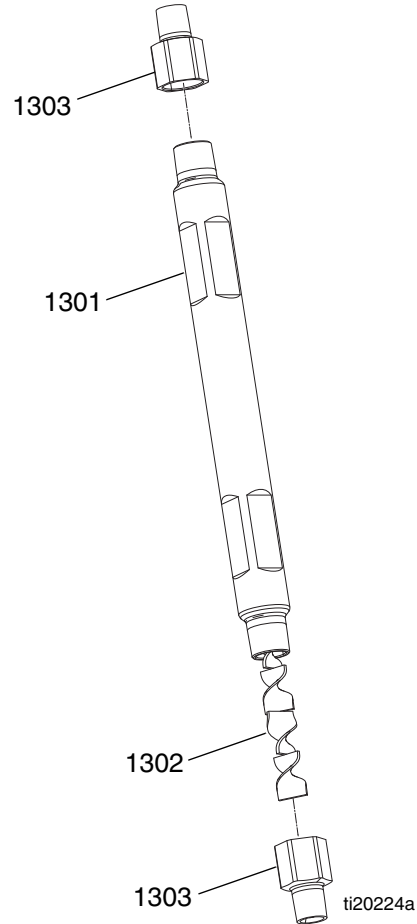



FIG. 20

See FIG. 20.

1. Remove bushings (AA) on each end of static mixer assembly and discard.
2. Disconnect 3/4 in. ID hose (EE) from pump outlet check valve then remove and discard the nipple (BB) used to connect the check valve to the hose.
3. Install static mixer (CC) onto pump outlet check valve (DD).
4. Install 3/4 in. ID hose (EE) onto the static mixer (CC) outlet.

Static Mixer (16T316)



 Apply pipe sealant to all non-swiveling pipe threads.

Ref.	Part	Description	Qty.
1301	---	TUBE, mixer	1
1302	24P886	MIXER, 12 element, stainless steel	1
1303	16T316	BUSHING, reducing 3/4 nptf x 1/2 npt	2
1304	---	SEALANT, pipe, stainless steel	1

---Not for sale.

Dimensions

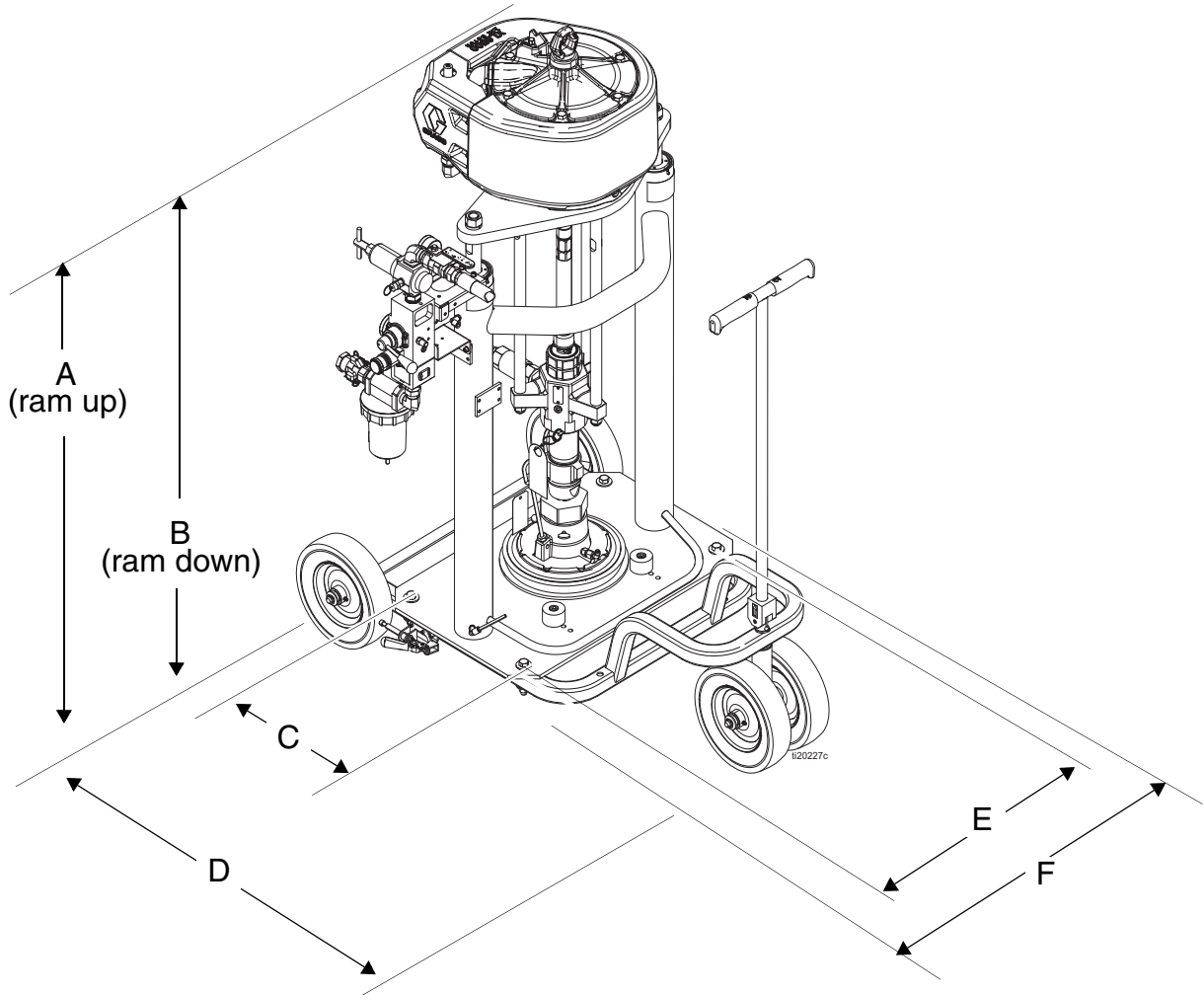

Model	A in. (m)	B in. (m)	C in. (m); Mounting Holes	D in. (m)	E in. (m); Mounting Holes	F in. (m)
Xtreme XL6500 PFP, no cart (16P957)	81.43 (2.07)	54-7/8 (1.39)	14 (0.36)	20-3/4 (0.53)	24 (0.61)	37 (0.94)
Xtreme XL10000 PFP, no cart (24X068)						
Xtreme XL6500 PFP, with cart (16T311)	87.18 (2.21)	60-5/8 (1.54)	14 (0.36)	47-5/8 (1.21)	24.0 (0.61)	39-3/4 (1.01)
Xtreme XL10000 PFP, with cart (24X069)						

Technical Data

Xtreme PFP		
	US	Metric
Maximum air inlet pressure	100 psi	0.7 MPa, 7 bar
Air inlet size	3/4 npt(f)	
Pump wetted parts	See Xtreme lowers manual.	
System wetted parts	Electroless nickel, polyurethane, PTFE-coated nitrile, polyethylene, PTFE, carbon steel, buna, 316 stainless steel, 17-4 stainless steel	
Ambient operating temperature range (supply system)	32-120 °F	0- 49°C
Sound data	See air motor manual.	
Maximum fluid working pressure		
Xtreme XL6500 PFP	7250 psi	50 MPa, 500 bar
Xtreme XL10000 PFP	7250 psi	50 MPa, 500 bar
Maximum air working pressure		
Xtreme XL6500 PFP	100 psi	690 kPa, 6.9 bar
Xtreme XL10000 PFP	100 psi	690 kPa, 6.9 bar
Weight		
16P957	325 lb	147 kg
16T311	392 lb	178 kg
24X068	365 lb	165 kg
24X069	432 lb	196 kg

Graco Standard Warranty

Graco warrants all equipment referenced in this document which is manufactured by Graco and bearing its name to be free from defects in material and workmanship on the date of sale to the original purchaser for use. With the exception of any special, extended, or limited warranty published by Graco, Graco will, for a period of twelve months from the date of sale, repair or replace any part of the equipment determined by Graco to be defective. This warranty applies only when the equipment is installed, operated and maintained in accordance with Graco's written recommendations.

This warranty does not cover, and Graco shall not be liable for general wear and tear, or any malfunction, damage or wear caused by faulty installation, misapplication, abrasion, corrosion, inadequate or improper maintenance, negligence, accident, tampering, or substitution of non-Graco component parts. Nor shall Graco be liable for malfunction, damage or wear caused by the incompatibility of Graco equipment with structures, accessories, equipment or materials not supplied by Graco, or the improper design, manufacture, installation, operation or maintenance of structures, accessories, equipment or materials not supplied by Graco.

This warranty is conditioned upon the prepaid return of the equipment claimed to be defective to an authorized Graco distributor for verification of the claimed defect. If the claimed defect is verified, Graco will repair or replace free of charge any defective parts. The equipment will be returned to the original purchaser transportation prepaid. If inspection of the equipment does not disclose any defect in material or workmanship, repairs will be made at a reasonable charge, which charges may include the costs of parts, labor, and transportation.

THIS WARRANTY IS EXCLUSIVE, AND IS IN LIEU OF ANY OTHER WARRANTIES, EXPRESS OR IMPLIED, INCLUDING BUT NOT LIMITED TO WARRANTY OF MERCHANTABILITY OR WARRANTY OF FITNESS FOR A PARTICULAR PURPOSE.

Graco's sole obligation and buyer's sole remedy for any breach of warranty shall be as set forth above. The buyer agrees that no other remedy (including, but not limited to, incidental or consequential damages for lost profits, lost sales, injury to person or property, or any other incidental or consequential loss) shall be available. Any action for breach of warranty must be brought within two (2) years of the date of sale.

GRACO MAKES NO WARRANTY, AND DISCLAIMS ALL IMPLIED WARRANTIES OF MERCHANTABILITY AND FITNESS FOR A PARTICULAR PURPOSE, IN CONNECTION WITH ACCESSORIES, EQUIPMENT, MATERIALS OR COMPONENTS SOLD BUT NOT MANUFACTURED BY GRACO. These items sold, but not manufactured by Graco (such as electric motors, switches, hose, etc.), are subject to the warranty, if any, of their manufacturer. Graco will provide purchaser with reasonable assistance in making any claim for breach of these warranties.

In no event will Graco be liable for indirect, incidental, special or consequential damages resulting from Graco supplying equipment hereunder, or the furnishing, performance, or use of any products or other goods sold hereto, whether due to a breach of contract, breach of warranty, the negligence of Graco, or otherwise.

FOR GRACO CANADA CUSTOMERS

The Parties acknowledge that they have required that the present document, as well as all documents, notices and legal proceedings entered into, given or instituted pursuant hereto or relating directly or indirectly hereto, be drawn up in English. Les parties reconnaissent avoir convenu que la rédaction du présente document sera en Anglais, ainsi que tous documents, avis et procédures judiciaires exécutés, donnés ou intentés, à la suite de ou en rapport, directement ou indirectement, avec les procédures concernées.

Graco Information

For the latest information about Graco products, visit www.graco.com.

For patent information, see www.graco.com/patents.

TO PLACE AN ORDER, contact your Graco distributor or call to identify the nearest distributor.

Phone: 612-623-6921 or Toll Free: 1-800-328-0211 Fax: 612-378-3505

All written and visual data contained in this document reflects the latest product information available at the time of publication. Graco reserves the right to make changes at any time without notice.

Original instructions. This manual contains English. MM 3A2798

Graco Headquarters: Minneapolis
International Offices: Belgium, China, Japan, Korea

GRACO INC. AND SUBSIDIARIES • P.O. BOX 1441 • MINNEAPOLIS MN 55440-1441 • USA

Copyright 2012, Graco Inc. All Graco manufacturing locations are registered to ISO 9001.

www.graco.com

Revision L, September 2018