

Instructions–Parts List



VISCON High Pressure Fluid Heater

307363S

Used for variable heating of fluids.

3000 psi (21 MPa, 210 bar) Maximum Working Pressure
80–190°F (26–88°C) Temperature Range

Model 226816, Series F 120 Volt
Model 226819, Series F 240 Volt

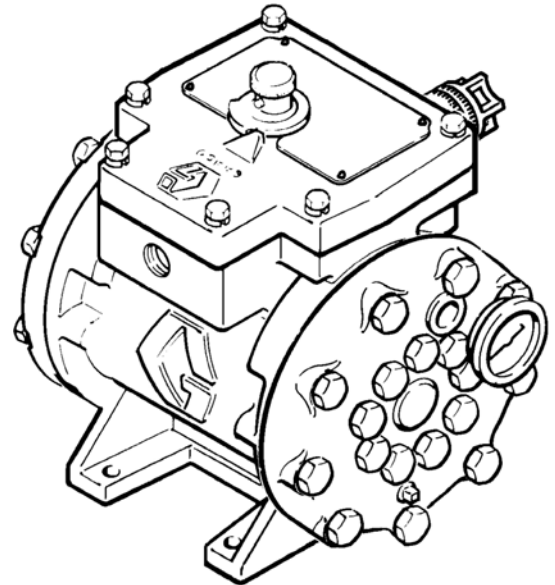
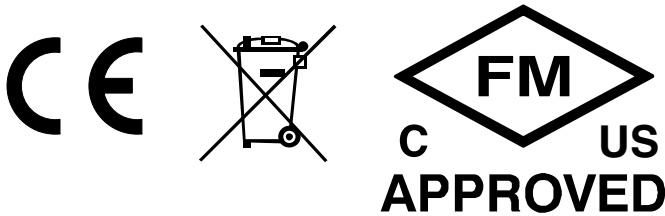

FM Approved as explosion proof for Class I, Division 1, Group D, Hazardous Locations, Temp Code (identification number) T3C. See the Technical Data on page 20 for additional information on this code.



Important Safety Instructions

Read all warnings and instructions in this manual.
Save these instructions.

WARNING

Hazard of Using Fluids Containing Halogenated Hydrocarbons

Never use 1,1,1-trichloroethane, methylene chloride, other halogenated hydrocarbon solvents or fluids containing such solvents in this equipment. Such use could result in a serious chemical reaction, with the possibility of explosion, which could cause death, serious injury, and/or substantial property damage.

Consult your fluid suppliers to ensure that the fluids being used are compatible with aluminum and zinc parts.

Table of Contents

Warnings	2
Installation	5
Operation	8
Pressure Relief Procedure	8
Maintenance	11
Troubleshooting	12
Service	14
Parts	18
Technical Data	20
Dimensions	22
Mounting Hole Layout	22
Warranty	24
Graco Information	24

Symbols

Warning Symbol



This symbol alerts you to the possibility of serious injury or death if you do not follow the instructions.

Caution Symbol



This symbol alerts you to the possibility of damage to or destruction of equipment if you do not follow the corresponding instructions.

! WARNING



INSTRUCTIONS

EQUIPMENT MISUSE HAZARD

Equipment misuse can cause the equipment to rupture or malfunction and result in serious injury.

- This equipment is for professional use only.
- Read all instruction manuals, tags, and labels before operating the equipment.
- Use the equipment only for its intended purpose. If you are uncertain about usage, call your Graco distributor.
- Do not alter or modify this equipment. Use only genuine Graco parts and accessories.
- Check equipment daily. Repair or replace worn or damaged parts immediately.
- Do not exceed the maximum working pressure of the lowest rated system component. These heaters have a **3000 psi (21 MPa, 210 bar) maximum working pressure**.
- Use fluids and solvents which are compatible with the equipment wetted parts. Refer to the **Technical Data** section of all equipment manuals. Read the fluid and solvent manufacturer's warnings.
- Do not use hoses to pull equipment.
- Route hoses away from traffic areas, sharp edges, moving parts, and hot surfaces. Do not expose Graco hoses to temperatures above 82°C (180°F) or below -40°C (-40°F).
- Do not touch the heater during operation; it is very hot.
- Comply with all applicable local, state, and national fire, electrical, and safety regulations.

WARNING



SKIN INJECTION HAZARD

Spray from the gun, hose leaks, or ruptured components can inject fluid into your body and cause extremely serious injury, including the need for amputation. Fluid splashed in the eyes or on the skin can also cause serious injury.

- Fluid injected into the skin might look like just a cut, but it is a serious injury. **Get immediate surgical treatment.**
- Do not point the gun at anyone or at any part of the body.
- Do not put your hand or fingers over the spray tip.
- Do not stop or deflect leaks with your hand, body, glove or rag.
- Do not “blow back” fluid; this is not an air spray system.
- Always have the tip guard and the trigger guard on the gun when spraying.
- Be sure the gun trigger safety operates before spraying.
- Lock the gun trigger safety when you stop spraying.
- Follow the **Pressure Relief Procedure** on page 8 whenever you: are instructed to relieve pressure; stop spraying; clean, check, or service the equipment; and install or clean the spray tip.
- Tighten all fluid connections before operating the equipment.
- Check the hoses, tubes, and couplings daily. Replace worn, damaged, or loose parts immediately. Permanently coupled hoses cannot be repaired; replace the entire hose.
- Use only Graco approved hoses. Do not remove any spring guard that is used to help protect the hose from rupture caused by kinks or bends near the couplings.
- Wear hearing protection when operating this equipment.

WARNING



FIRE AND EXPLOSION HAZARD

Improper grounding, poor ventilation, open flames or sparks can cause a hazardous condition and result in a fire or explosion and serious injury.

- Ground the equipment and the object being sprayed. Refer to **Grounding** on page 5.
- If there is any static sparking or you feel an electric shock while using this equipment, **stop spraying immediately**. Do not use the equipment until you identify and correct the problem.
- Provide fresh air ventilation to avoid the buildup of flammable fumes from solvents or the fluid being sprayed.
- Keep the spray area free of debris, including solvent, rags, and gasoline.
- Electrically disconnect all equipment in the spray area.
- Extinguish all open flames or pilot lights in the spray area.
- Do not smoke in the spray area.
- Do not turn on or off any light switch in the spray area while operating or if fumes are present.
- Do not operate a gasoline engine in the spray area.



TOXIC FLUID HAZARD

Hazardous fluid or toxic fumes can cause serious injury or death if splashed in the eyes or on the skin, inhaled, or swallowed.

- Know the specific hazards of the fluid you are using.
- Store hazardous fluid in an approved container. Dispose of hazardous fluid according to all local, state and national guidelines.
- Always wear protective eyewear, gloves, clothing and respirator as recommended by the fluid and solvent manufacturer.



MOVING PARTS HAZARD

Moving parts can pinch or amputate your fingers.

- Keep clear of all moving parts when you start or operate the equipment.
- Before you service this equipment, follow the **Pressure Relief Procedure** on page 8 to prevent the equipment from starting unexpectedly.

Installation

Grounding

⚠ WARNING



FIRE AND EXPLOSION HAZARD
Before operating the pump, ground the system as explained below. Also read the section **FIRE AND EXPLOSION HAZARD** on page 4.

1. *Pump*: use a ground wire and clamp as shown in your separate pump manual.
2. *Air hoses*: use only electrically conductive air hoses.
3. *Fluid hoses*: use only electrically conductive fluid hoses.
4. *Heater*: by wiring to a properly grounded power supply through the electrical connections. In a mobile installation, be sure the truck or trailer is grounded to a true earth ground, also.
5. *Air compressor or hydraulic power supply*: follow manufacturer's recommendations.
6. *Spray gun*: grounding is obtained through connection to a properly grounded fluid hose and pump.
7. *Object being sprayed*: according to your local code.
8. *All solvent pails used when flushing*, according to local code. Use only metal pails, which are conductive, placed on a grounded surface. Do not place the pail on a nonconductive surface, such as paper or cardboard, which interrupts the grounding continuity.
9. *To maintain grounding continuity when flushing or relieving pressure*, always hold a metal part of the gun firmly to the side of a grounded metal pail, then trigger the gun.

Installation

HEATED CIRCULATING SYSTEM

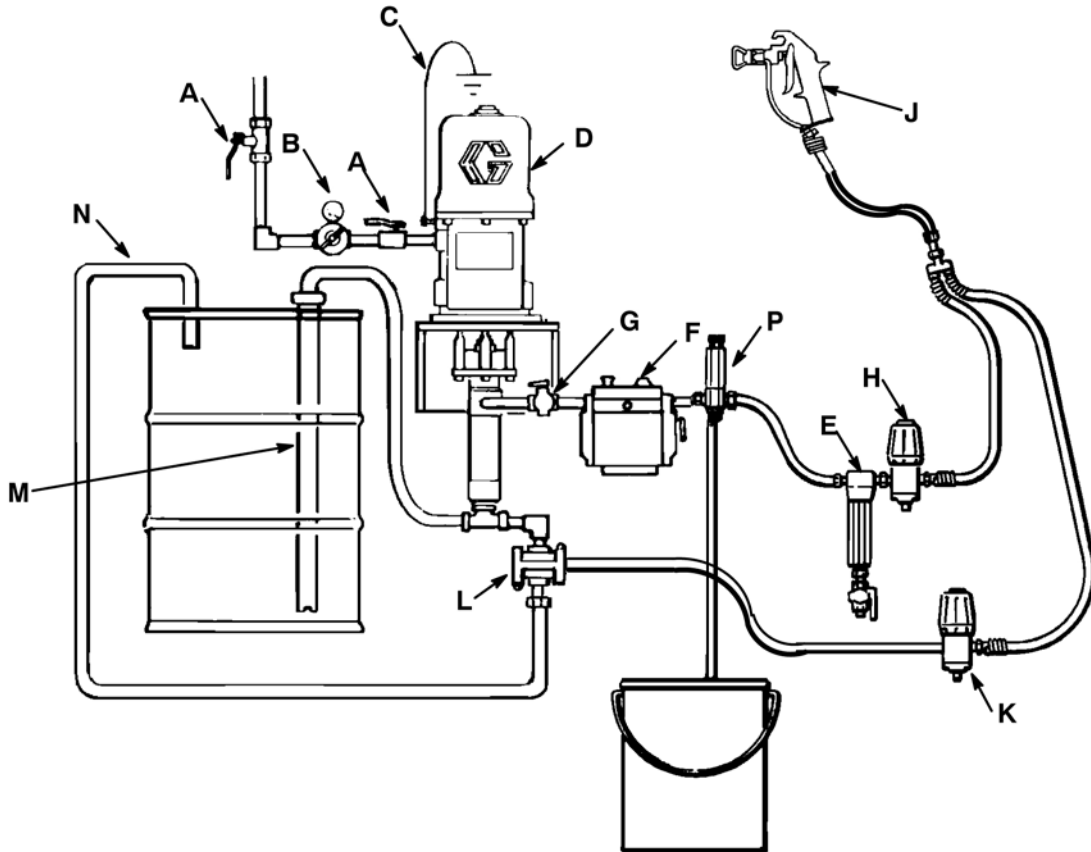

KEY

A Bleed-type Master Air Valve
B Air Regulator and Gauge
C Ground Wire
D Pump
E Fluid Filter with Drain Valve

F Vis-Con Heater
G Fluid Shutoff Valve
H Fluid Pressure Regulator
J Spray Gun
K Back Pressure Valve

L Director Valve
M Siphon tube
N Drain Back Tube
P Pressure Relief Valve

Fig. 1

⚠ WARNING

To reduce the risk of serious injury, including fluid injection, splashing in the eyes or on the skin, burns from hot fluid or heated surfaces, electric shock or property damage, always follow these precautions when installing the heater.

1. Shut off the electric circuit.
2. Relieve air and fluid pressure in the system.
3. Have a trained and qualified person install and wire the heater.
4. Be sure the installation is in compliance with all local, state, and national codes.
5. Do not install any shutoff devices downstream from the heater.

⚠ WARNING

Heat causes the fluid to expand. If fluid in the heated portion of your system is trapped with nowhere to expand, it can cause a system rupture. A system rupture can result in serious injury and property damage. Be sure your system has an adequate way to handle heat expansion.

1. Use flexible hoses between the heater and gun.
2. OR, install a properly sized accumulator downstream from the heater.
3. OR, install a pressure relief valve (P – see the **Installation** drawing above), preset to relieve pressure when it exceeds the system's maximum working pressure.
4. Never install any shutoff device between the heater and gun. If you are using a fluid regulator before the gun, never use it as a shutoff device.

Installation

Mounting the Heater

This **Typical Installation** is only a guide to setting up a heated, circulating spray system. For assistance in designing a system to suit your needs, contact your Graco distributor.

Use 1/4 in. diameter mounting screws (P) to install the heat insulators (19) on each side of the bolt holes in the heater housing (Q). See Fig. 2. Mount the heater near the object to be sprayed, but outside the spray area. Be sure the surface on which you mount the heater can support the weight of the heater, filters, hoses, and fluid. See the **Dimensions** on page 22 and **Technical Data** on page 20.

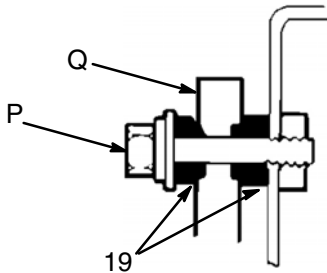

Fig. 2

Install a fluid shutoff valve (G) UPSTREAM from the heater. This is used to isolate the heater when it requires servicing. DOWNSTREAM, install a fluid filter and drain valve (E). The filter removes sediment that may have collected in the heater, which could clog the spray gun.

Connecting the Hoses

Connect the fluid lines to the 1/2 npt(f) inlet and outlet of the heater. See the **Typical Installation**, on page 6.

To minimize heat loss, fluid lines should be insulated when they are especially long if the environment is cool.

⚠ WARNING

When using a flexible power cord, the attached equipment is no longer explosion proof rated. To reduce the risk of serious injury from a fire or explosion, do not use the heater near flammable materials or vapors.

Locate the heater where operators will not come in contact with the hot metal surfaces.

Wiring

Remove the heater cover (20). Connect the electric wires of the circuit to the heater leads (R, S) with connectors (T). Crimp the terminal (24) onto the ground wire (U) of the circuit and connect to the heater ground connection screw (5). See Fig. 3.

⚠ WARNING

All wire nuts used for heater connections must be rated at 150°C or higher. NEVER use wire nuts rated less than 150°C; they cannot withstand the heat generated.

NOTE: Be sure your voltage supply agrees with the heater voltage. The 120 volt heater draws 18 amps, and the 240 volt heater draws 9 amps.

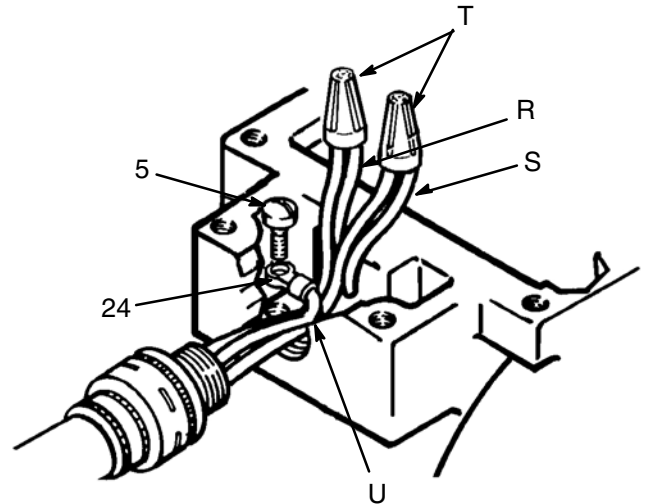

Fig. 3

Operation

Pressure Relief Procedure

WARNING



SKIN INJECTION HAZARD

Fluid under high pressure can be injected through the skin and cause serious injury. To reduce the risk of an injury from injection, splashing fluid, or moving parts, follow the **Pressure Relief Procedure** whenever you:

- are instructed to relieve the pressure,
- stop spraying,
- check or service any of the system equipment,
- or install or clean the spray tip.

1. Lock the gun trigger safety.
2. Shut off the main power to the heater.
3. Circulate the fluid for at least 10 minutes to cool the heated fluid and heater.
4. Shut off all air and fluid supplies.
5. Unlock the gun trigger safety. Maintaining firm metal-to-metal contact between the gun and a grounded metal pail, trigger the gun to relieve pressure. Lock the gun trigger safety.
6. Open the fluid filter drain valve, having a container ready to catch the fluid.

Operation

Flushing the Heater Before First Use

The heater was factory tested in lightweight oil. Use low pressure and a compatible solvent to flush the system. While the system is pressurized, check it carefully for leaks at all fluid connections. Pump out the solvent, relieve the system pressure, and tighten any leaking connections. Prime the system and check to be sure that all leaks have stopped.

⚠ WARNING

To reduce the risk of serious injury when flushing:

1. Use the lowest possible pressure to reduce the risk of fluid injection and splashing solvent in the eyes or on the skin.
2. Maintain firm metal-to-metal contact between a metal part of the gun and a grounded metal pail to reduce the risk of static sparking which can cause a fire or explosion.

⚠ WARNING

To reduce the risk of serious injury from a fire or explosion, never operate the heater with its covers removed.

Priming the System (Refer to page 6)

Pump the fluid until all air has been purged from the system, to permit proper heating and spraying. In a completely closed, circulating system, use a director valve (L) attached to the pump intake to purge the system. See the **Typical Installation** on page 6.

Setting the Heater Controls (See Fig. 4)

NOTE: The knob settings for Series E and older Vis-Con heaters will differ from Series F heaters (covered in this manual). It's important that you take this into consideration when setting the heaters. Refer to the charts which illustrate the difference.

1. Stop the pump.
2. Set the control knob (V) at 4 or 5 (trial setting) and let the heater warm up for about 10 minutes. See Fig. 5.

NOTE: Start the pump and circulate the fluid at a low speed – 10 to 20 oz/min. (0.30 to 0.35 liter/min.) – during the warmup.

Adjusting for Spraying

1. Start the pump and check the fluid flow through the gun.
2. Readjust the control knob setting, if necessary, to obtain the proper temperature for spraying.
3. In a Hydra-Spray® system with a tip installed in the gun, adjust the pump speed (use the pump air regulator) to the lowest fluid pressure that will completely atomize the fluid.
4. In a circulating system, adjust the back pressure valve, also.

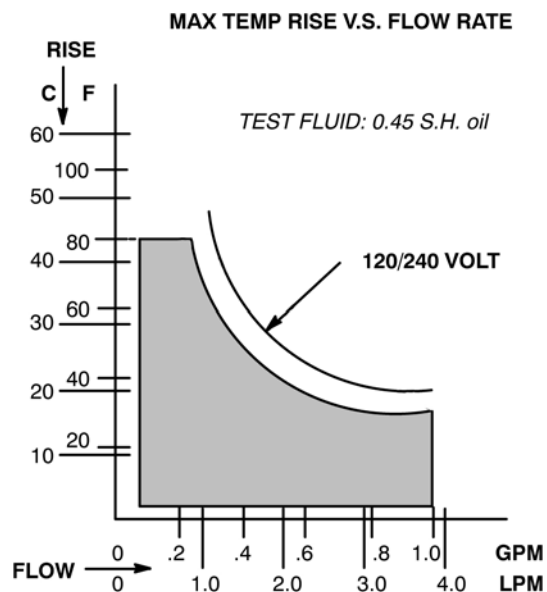

Fig. 4

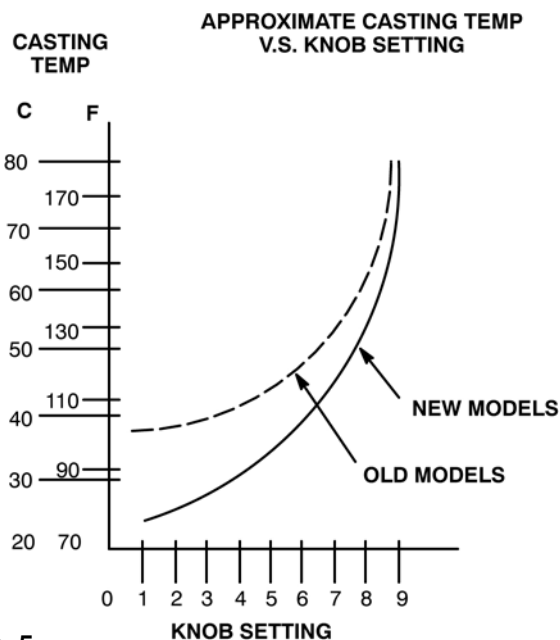

Fig. 5

Operation

Determining the Proper Fluid Temperature

⚠ CAUTION

Use the lowest temperature setting needed, for maximum heater life. Operating the heater at its highest setting – over 82°C (180°F) – for long periods of time decreases the heater life.

Higher than necessary temperatures also causes the fluid to dry out, resulting in a poor finish and clogging the heater.

The chart in Fig. 6 is used on determining the Under-Boil® temperature. It also shows the effect of temperature on reducing viscosity. Notice that most of the viscosity reduction occurs by 55°C (130°F).

Under-Boil is the Graco method of hot, airless spraying in which the fluid is heated to a temperature just under the boiling point of its most volatile solvent.

To find the Under-Boil temperature of your fluid:

1. Pour a small sample into a heat-proof container.
2. Measure and record the temperature and viscosity of the fluid. Use a No. 2 Zahn cup.
3. Heat water in a large container to 93°C (200°F). Place the sample in the water.

Effect of Temperature in Reducing Two Fluids to a Sprayable Viscosity

The chart in Fig. 7 shows the effect of temperature in reducing two fluids to a sprayable viscosity – in the range of 20 to 34 seconds using a No. 2 Zahn cup.

Notice that temperature has more of an effect on high solid fluids than on thin enamels. That is, for the same 10° temperature rise, more viscosity reduction occurs in the high solid fluid than the enamel. This shows that high solid fluids are “temperature sensitive,” which needs to be taken into consideration when planning your system.

Also note that once the fluid is reduced to about 34 on the chart, viscosity reduction starts to level off. Therefore, high temperatures will not significantly improve sprayability, but will use more energy.

4. At every 10° temperature rise, measure and record the viscosity and temperature. Do this until solvents start boiling off and the viscosity starts to level off – usually 71° to 77°C (160° to 170°F).
5. Subtract the lowest viscosity reading from the highest one. Multiply that result by 0.90. Subtract the new result from the highest viscosity reading. Find this number on your temperature and viscosity records. This is the temperature to use in your Under-Boil system.

EFFECT OF TEMPERATURE ON REDUCING VISCOSITY UNDER-BOIL METHOD

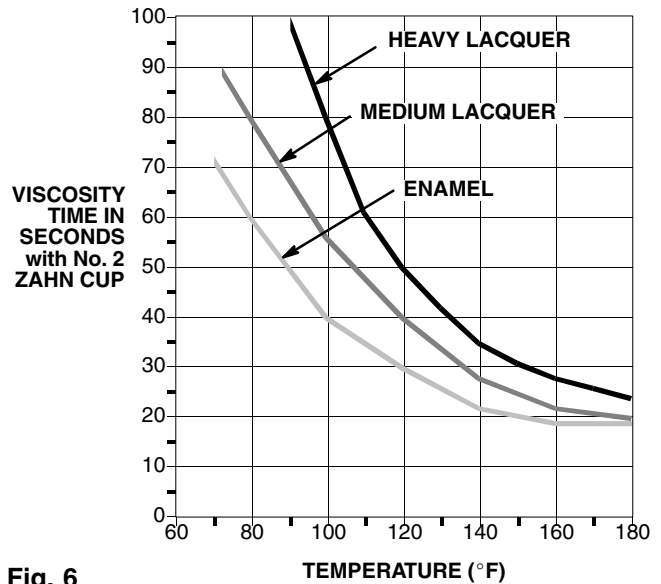

Fig. 6

EFFECT OF TEMPERATURE ON VISCOSITY

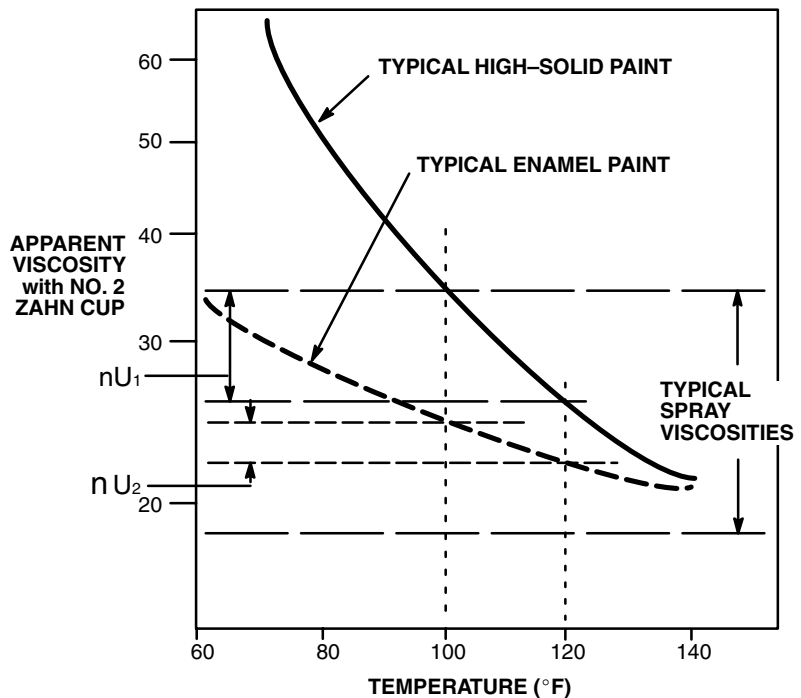

Fig. 7

Maintenance

Flushing After Use

1. Drain and clean the fluid filter frequently to be sure it filters the fluid thoroughly. Always relieve system pressure first, and cool the fluid, if possible. If not possible, wear protective eyewear and gloves to protect yourself from possible burns.
2. Flush the heater often enough to prevent a buildup of dried sediment in it.

⚠ WARNING

Before flushing, always shut off the main power to the heater. Circulate the fluid through the system for at least 10 minutes to cool the fluid and heater. This reduces the risk of serious injury from burns.

⚠ CAUTION

Clogged fluid passages can be very difficult to clean. They also reduce heating efficiency, flow rate, and pressure. To prevent clogged passages, do not overheat or dry out the fluid, and flush frequently, including whenever the system or heater is not in use.

3. If the system runs dry, refill it immediately before fluid can dry in it. Or flush the system thoroughly if you are not going to use it immediately.
4. To drain the fluid from the heater, first relieve all system pressure. Cool the fluid, if possible. Remove the drain plug (7) in either end plate and drain the fluid into a container. See. Fig. 8.
5. Shut down.

⚠ CAUTION

When shutting down the system, turn the control knob (V) to set point 1 and circulate the fluid for at least 10 minutes before shutting off the pump. This allows unheated fluid to gradually cool the heater and heated fluid.

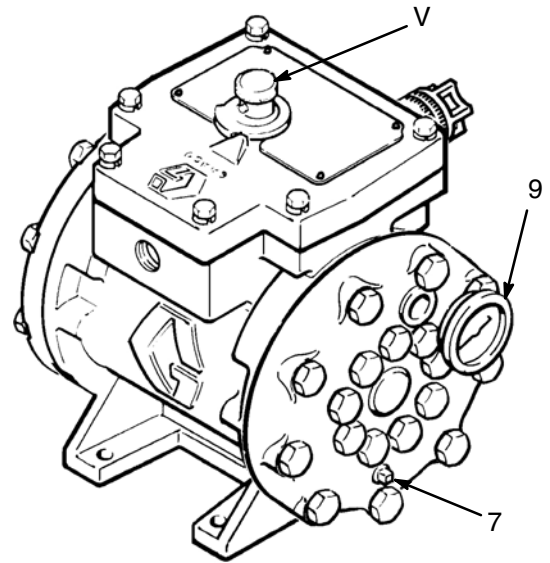
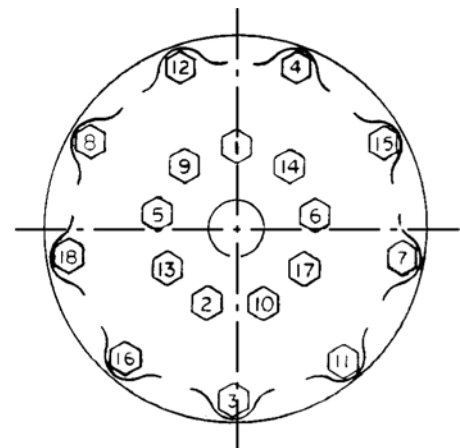

Fig. 8

Unclogging Fluid Passages

1. Remove an end plate (21) and use a wire bottle brush to clean. If necessary, use 1/2 in. (13 mm) hand reamer to remove hard, caked deposits.
2. Put the end plate back on, turning all screws hand tight.
3. Follow the sequence shown in Fig. 9, torquing each screw to 50 in-lb (5.6 N•m).
4. Torque them again, using the same sequence, to 175–225 in-lb (20–25 N•m).



Torquing Sequence

Fig. 9

Troubleshooting

WARNING

To reduce the risk of serious injury whenever you are instructed to relieve pressure, always follow the **Pressure Relief Procedure** on page 8.

Before servicing this equipment always make sure to **relieve the pressure**.

Check all possible problems and solutions before disassembling the heater.

PROBLEM	CAUSE	SOLUTION
Heater will not heat	No current.	Check circuit, fuses.
	Faulty circuit board.	Replace the cover and circuit board assembly (20).
	Burned out heater element.	Replace the housing.
Temperature too low	Fluid requires more warmup time.	Increase warmup time.
	Wrong temperature setting.	Adjust the knob.
	Flow rate too high.	Reduce flow rate or use two heaters.
	Clogged fluid passages.	Clean. Flush regularly.
	Faulty circuit board.	Replace the cover and circuit board assembly (20).
Temperature too high	Wrong temperature setting.	Adjust the knob.
	Faulty circuit board.	Replace the cover and circuit board assembly (20).
Too much pressure drop / fluid will not flow	Flow rate too high.	Reduce flow rate or use two heaters.
	Clogged fluid passages.	Clean. Flush regularly.
Leakage from end plates	Loose bolts, damaged seals.	Tighten or replace seals.

Service

Replacing the Cover and Circuit Board Assembly

WARNING

All service to the heater must be performed by a qualified electrician to reduce the risk of electric shock or serious personal injury.

Follow the **Pressure Relief Procedure** on page 8 before continuing.

NOTE: Parts with ref. nos. 1, 3, and 20a–20h are included in the cover and circuit board assembly (20). To replace these parts, order 217184 for Heater Model 226816 or 217185 for Model 226819.

1. Remove the six old screws (3) and lockwasher (1). Discard.
2. Swing the old cover (20a) into an upright position on the heater housing edge.
3. Remove the old screw (20c) and lockwasher (20d) from the threaded terminal in the lower right-hand corner of the circuit board (20b) to disconnect the black or white input wire (R). Discard the screw and lockwasher.
4. Disengage the wiring harness female connector (20e) from male connector in lower left-hand corner of the circuit board (20b).
5. Unscrew the thermistor (20f) from the heater housing. Discard the thermistor wiring harness.
6. Remove the nut (4) from the right heat element terminal (W). Remove the small white wire (20g).
7. Remove the nut (4) from the left heat element terminal (X) and remove the heavier black or white wire (20h). Discard the cover and circuit board assembly. Save the nuts (4).
8. Reassemble the new parts in the reverse order of removal, being sure wires are routed carefully and not in a position where they could be pinched when installing the cover on the heater housing.
9. Tighten the screw (20c) and terminal (W, X) nuts (4) securely.
10. Apply terminal grease (Part No. 110009) to the tip of the thermistor (20f) before threading it into the housing.

Service

- △₁ White
- △₂ White 120V
Black 240V
- △₃ Apply thermal grease (Graco Part No. 110009) to tip.

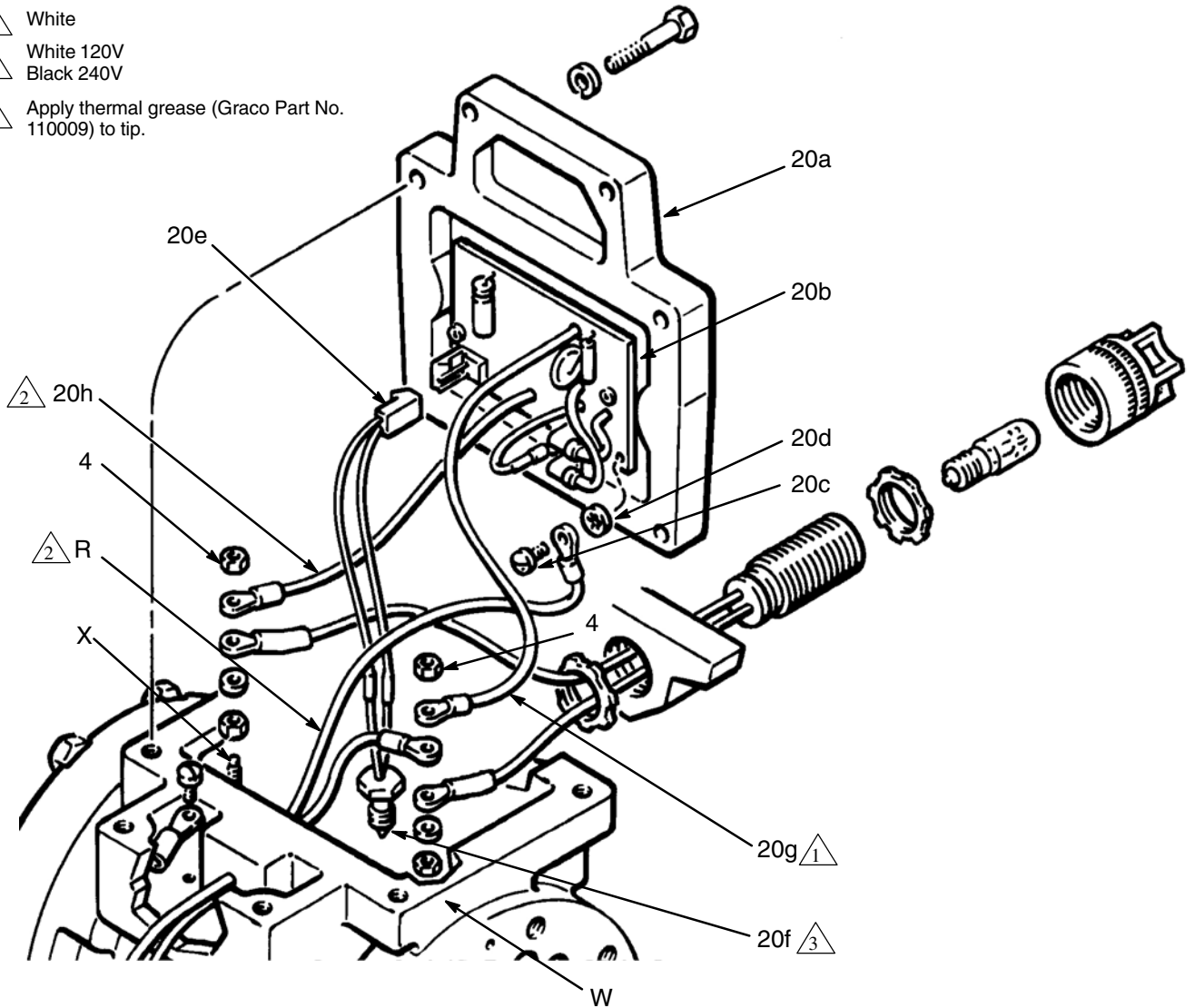

Fig. 10

Service

Replacing the Indicator Lamp

⚠ WARNING

All service to the heater must be performed by a qualified electrician.

To reduce the risk of serious injury, including fluid injection, burns, or electric shock, always shut off the power to the heater, relieve fluid and air pressure in the pump, and allow the fluid to cool before servicing the heater.

1. Unscrew the lens cap (49).

2. Remove the lamp (47) and replace it with a new lamp.
3. Screw the lens cap onto the socket (50) until the o-ring in the lens cap contacts the socket, then turn the lens cap 1/2 to 1 turn more to ensure a good seal.

⚠ WARNING

The terminals (46) on the ends of the indicator lamp socket (50) are special, fused terminals. To reduce the risk of fire or explosion which can result in serious injury and property damage. Use only original Graco replacement parts.

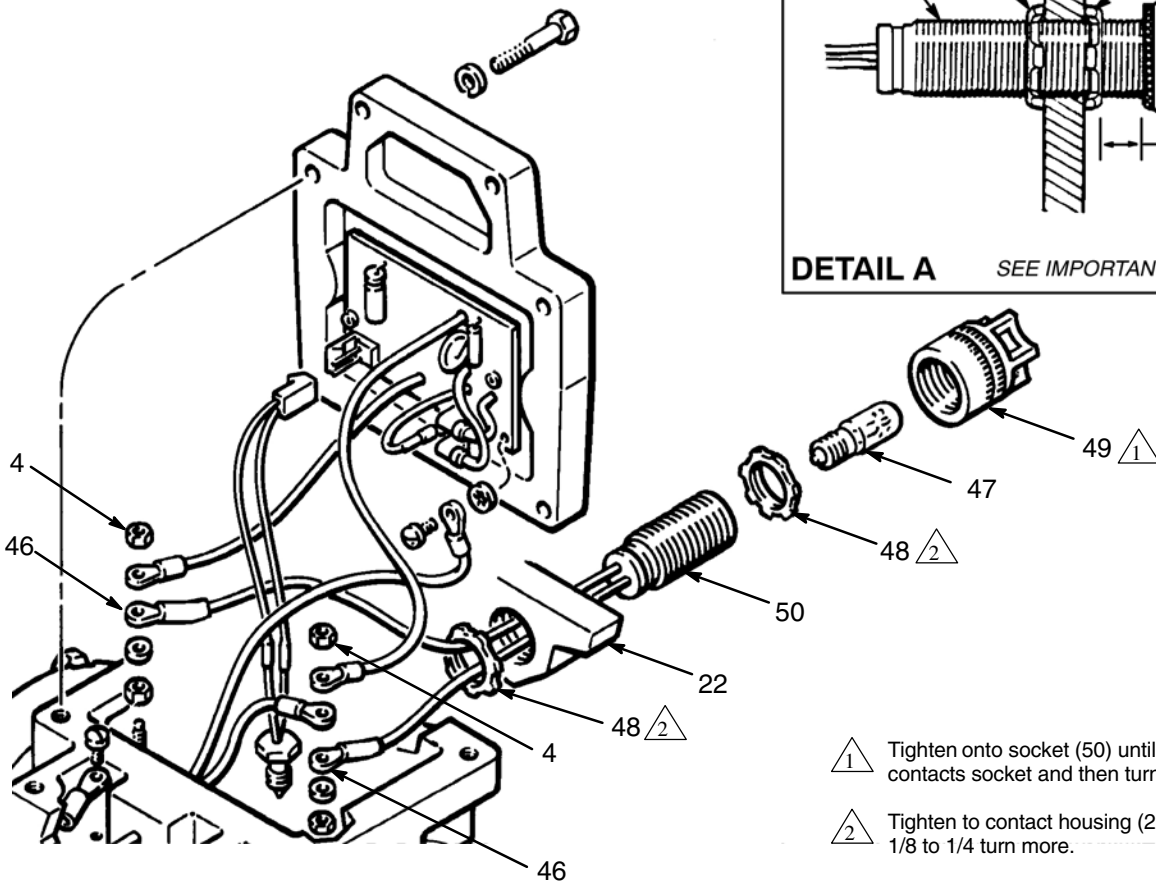
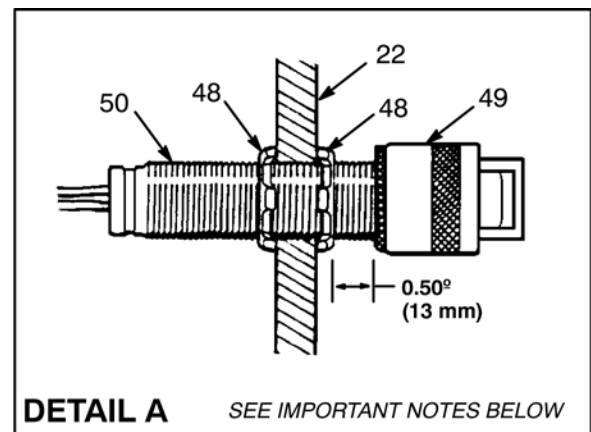
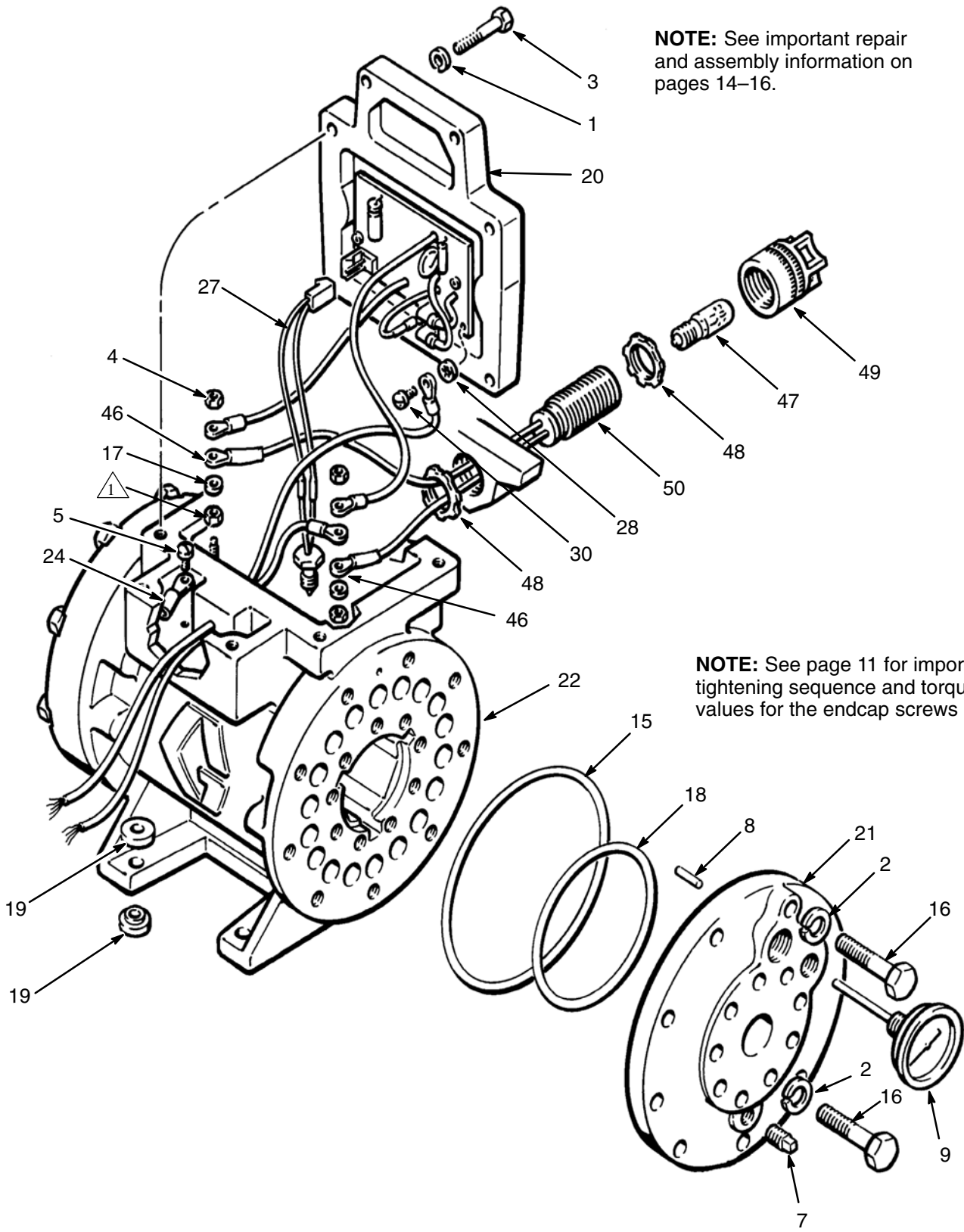

Fig. 11

- 1 Tighten onto socket (50) until seal in lens cap contacts socket and then turn 1/2 to 1 turn more.
- 2 Tighten to contact housing (22) and then turn 1/8 to 1/4 turn more.

Parts



NOTE: See important repair and assembly information on pages 14–16.

NOTE: See page 11 for important tightening sequence and torque values for the endcap screws (16).

Parts

Model 226819, Series F

240 Volt Heater
Includes items 1–50

Ref No.	Part No.	Description	Qty	Ref No.	Part No.	Description	Qty
1	100016	LOCKWASHER, 1/4 in.	6	21	176839	CAP, end, heater	2
2	100052	LOCKWASHER, 7/16 in.	36	22	215922	HOUSING, heater; 120 V <i>(Model 226816 only)</i>	1
3	100014	CAPSCREW, hex hd; 1/4–20 x 1–1/4 in.	6		215921	HOUSING, heater; 240 V <i>(Model 226819 only)</i>	1
4	100166	NUT, hex; 10–32 screw size	4				
5	100268	SCREW, mach, rd hd; 10–24 x 3/8 in.	1	24	104911	TERMINAL, ring; 12–10 ga. wire	1
7	100509	PLUG, std pipe; 1/4 in. npt size	3	27	215355	WIRING HARNESS	1
8	101097	PIN, grooved; 1/8 in. dia; 1/2 in. long	2	28	100272	LOCKWASHER	1
9	102124*	THERMOMETER, dial; 0 to 250°F (–18 to 121°C) range	1	47	106214	LAMP, incandescent; 120 V <i>(Model 226816 only)</i>	1
15	105496*	PACKING, o–ring; glass–filled PTFE	2		106215	LAMP, incandescent; 240 V <i>(Model 226819 only)</i>	1
16	105498	SCREW, cap, hex hd; 7/16 x 2 in. long	36	48	106216	LOCKNUT, external	2
17	157974	WASHER, flat; steel; 3/16 in. screw size	2	49	106217	CAP, lens	1
18	166412*	PACKING, o–ring; PTFE	2	50	109023	LAMP, socket, fused	1
19	167002	INSULATOR, heat	8				
20	222217	COVER & CIRCUIT BOARD ASSY 120 V <i>(Model 226816 only)</i>	1				
	222218	COVER & CIRCUIT BOARD ASSY 240 V <i>(Model 226819 only)</i>	1				

* *Keep these spare parts on hand to reduce down time.*

Technical Data

Category	Data
Voltage	<i>Model 226816, Series F:</i> 120 volts AC, single phase, 18 amp <i>Model 226819, Series F:</i> 240 volts AC, single phase, 9 amp
Explosion proof	Class 1 – Division 1 & 2, Group D, Hazardous Location
Heating element wattage	2100 watts
Fluid passage area	254 sq. in. (163, 870 mm ²)—8 watts per sq. in.; .013 watts/mm ² of heat transfer area
Fluid passage diameter and length	0.56 in. (14.2 mm ²), 12 ft (3.7 m)
Working pressure	up to 3000 psi (21 MPa, 207 bar) maximum
Thermometer range	0 to 250°F (–18 to 121°C)
Temperature range	80 to 190°F (26 to 88°C)
Weight	37.5 lb (17 kg)

* This heater has a surface temperature code (identification code) of T3C, indicating a maximum external (surface) temperature rating of 160°C (320°F) in accordance with Article 500 – Hazardous Locations – of NFPA 70 National Electrical Code and/or Section 18 – Hazardous Locations – of Part 1 of the Canadian Electrical Code. See and comply with the requirements of these and similar codes as to the proper location of the heater.

Circuit Diagrams

Model 226816, Series F For 120 Volt Heater

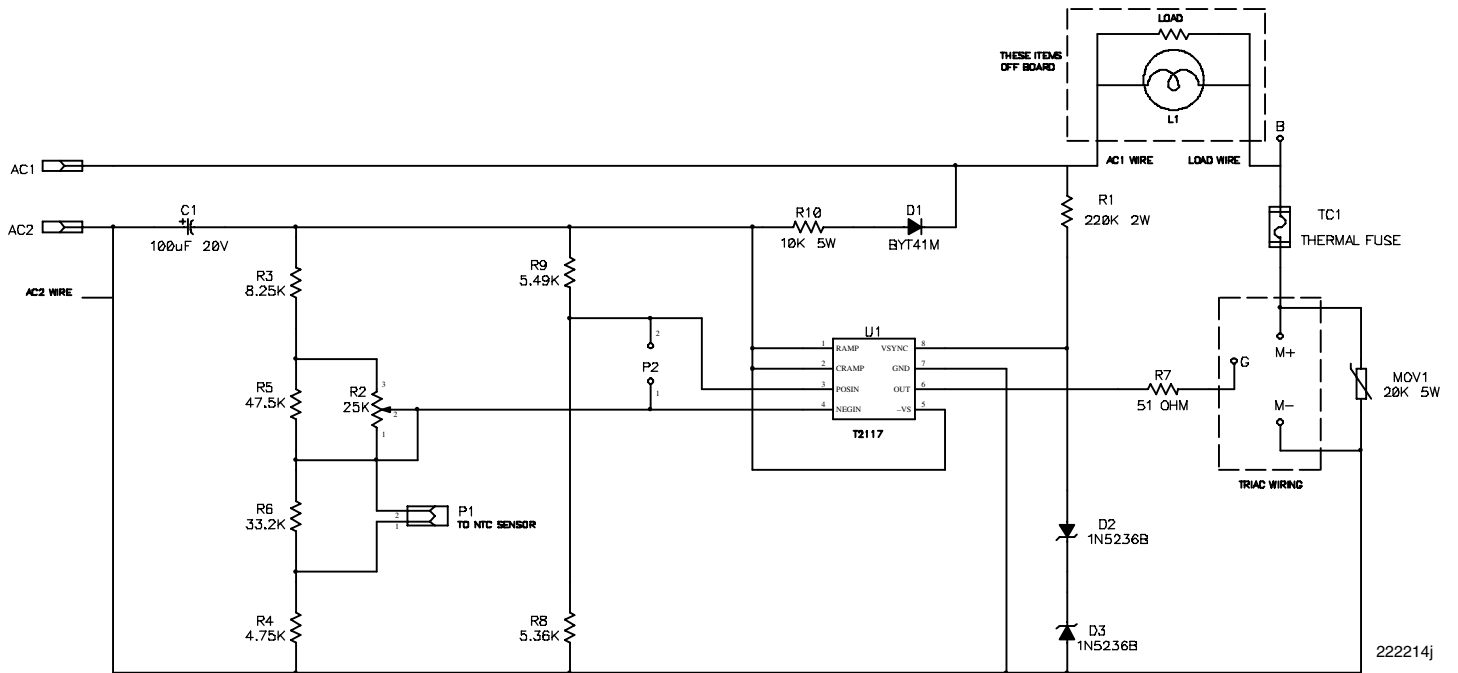

Model 226819, Series F For 240 Volt Heater

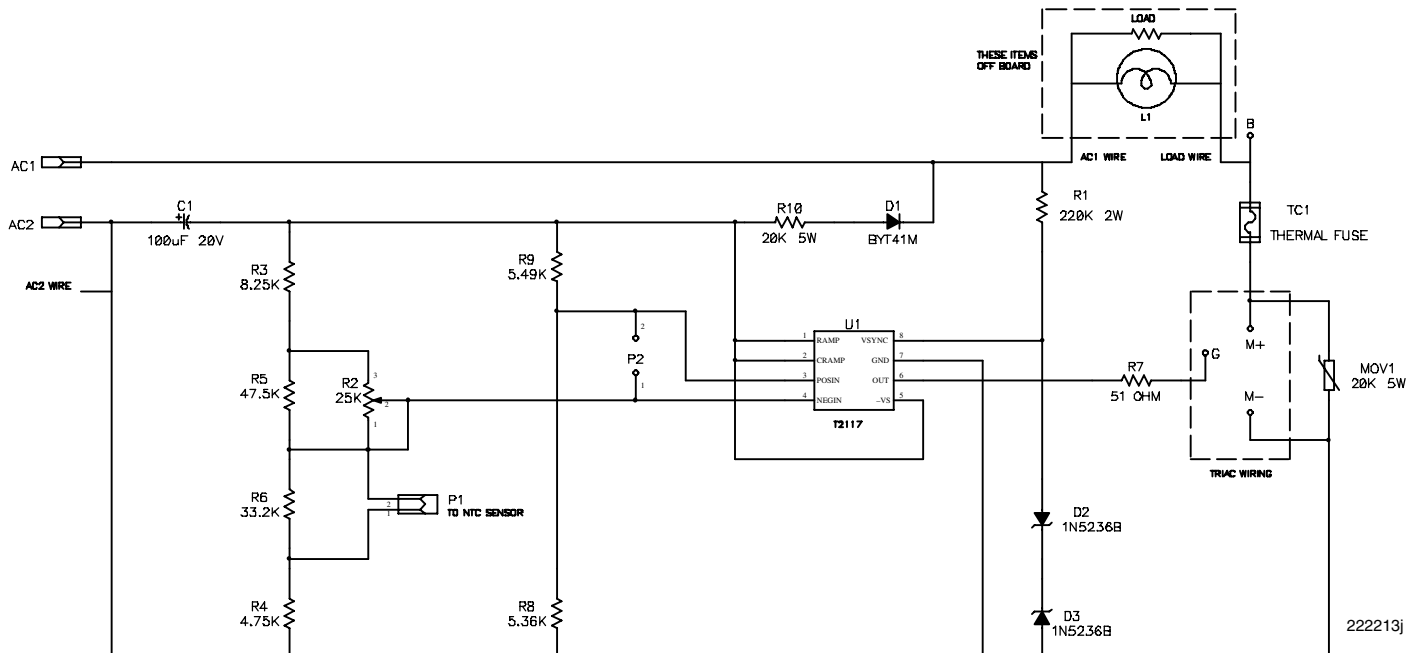

Dimensions

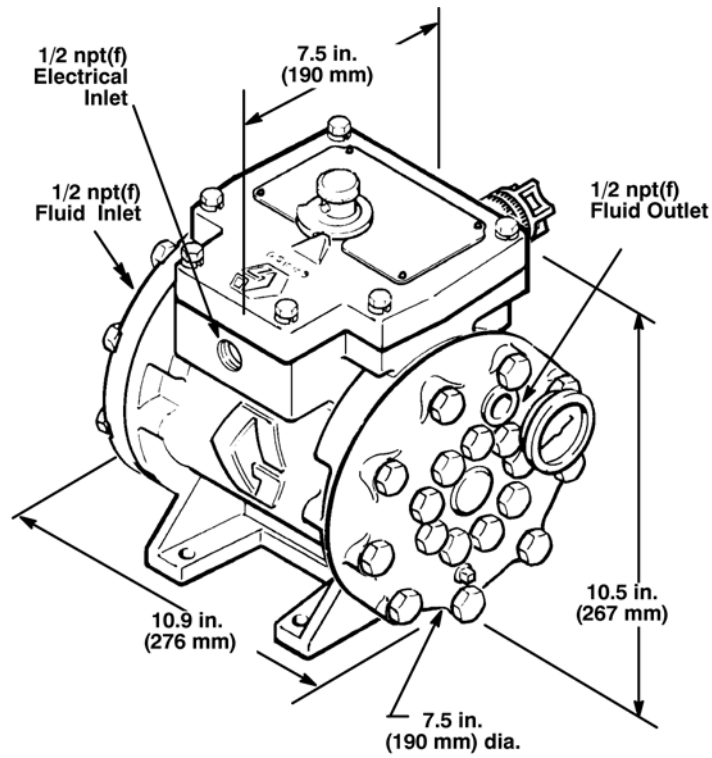

Mounting Hole Layout

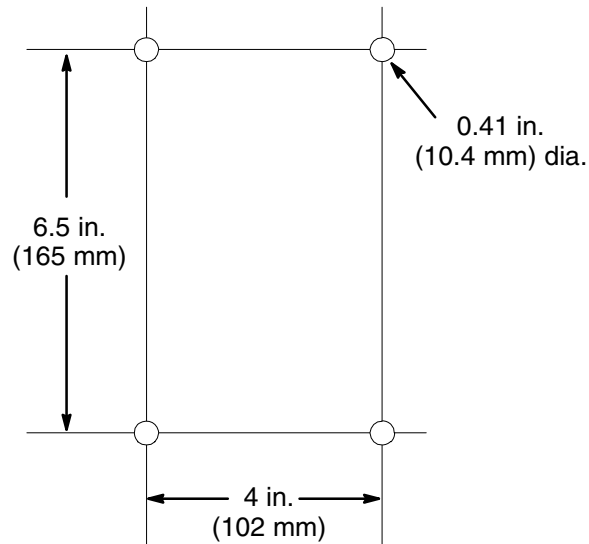

Graco Standard Warranty

Graco warrants all equipment manufactured by Graco and bearing its name to be free from defects in material and workmanship on the date of sale to the original purchaser for use. With the exception of any special, extended, or limited warranty published by Graco, Graco will, for a period of twelve months from the date of sale, repair or replace any part of the equipment determined by Graco to be defective. This warranty applies only when the equipment is installed, operated and maintained in accordance with Graco's written recommendations.

This warranty does not cover, and Graco shall not be liable for general wear and tear, or any malfunction, damage or wear caused by faulty installation, misapplication, abrasion, corrosion, inadequate or improper maintenance, negligence, accident, tampering, or substitution of non-Graco component parts. Nor shall Graco be liable for malfunction, damage or wear caused by the incompatibility of Graco equipment with structures, accessories, equipment or materials not supplied by Graco, or the improper design, manufacture, installation, operation or maintenance of structures, accessories, equipment or materials not supplied by Graco.

This warranty is conditioned upon the prepaid return of the equipment claimed to be defective to an authorized Graco distributor for verification of the claimed defect. If the claimed defect is verified, Graco will repair or replace free of charge any defective parts. The equipment will be returned to the original purchaser transportation prepaid. If inspection of the equipment does not disclose any defect in material or workmanship, repairs will be made at a reasonable charge, which charges may include the costs of parts, labor, and transportation.

THIS WARRANTY IS EXCLUSIVE, AND IS IN LIEU OF ANY OTHER WARRANTIES, EXPRESS OR IMPLIED, INCLUDING BUT NOT LIMITED TO WARRANTY OF MERCHANTABILITY OR WARRANTY OF FITNESS FOR A PARTICULAR PURPOSE.

Graco's sole obligation and buyer's sole remedy for any breach of warranty shall be as set forth above. The buyer agrees that no other remedy (including, but not limited to, incidental or consequential damages for lost profits, lost sales, injury to person or property, or any other incidental or consequential loss) shall be available. Any action for breach of warranty must be brought within two (2) years of the date of sale.

Graco makes no warranty, and disclaims all implied warranties of merchantability and fitness for a particular purpose in connection with accessories, equipment, materials or components sold but not manufactured by Graco. These items sold, but not manufactured by Graco (such as electric motors, switches, hose, etc.), are subject to the warranty, if any, of their manufacturer. Graco will provide purchaser with reasonable assistance in making any claim for breach of these warranties.

In no event will Graco be liable for indirect, incidental, special or consequential damages resulting from Graco supplying equipment hereunder, or the furnishing, performance, or use of any products or other goods sold hereto, whether due to a breach of contract, breach of warranty, the negligence of Graco, or otherwise.

FOR GRACO CANADA CUSTOMERS

The parties acknowledge that they have required that the present document, as well as all documents, notices and legal proceedings entered into, given or instituted pursuant hereto or relating directly or indirectly hereto, be drawn up in English. Les parties reconnaissent avoir convenu que la rédaction du présente document sera en Anglais, ainsi que tous documents, avis et procédures judiciaires exécutés, donnés ou intentés à la suite de ou en rapport, directement ou indirectement, avec les procédures concernées.

Graco Information

For the latest information about Graco products, visit www.graco.com.

TO PLACE AN ORDER, contact your Graco distributor or call to identify the distributor closest to you:

Phone: 612-623-6921 **or Toll Free:** 1-800-328-0211 **Fax:** 612-378-3505 Fax

This manual contains English. MM 307363

Graco Headquarters: Minneapolis
International Offices: Belgium, China, Japan, Korea

GRACO INC. P.O. BOX 1441 MINNEAPOLIS, MN 55440-1441

Copyright 1981, Graco Inc. is registered to ISO 9001

www.graco.com

Revised 04/2009